

TiM

Integrated Servo Motor

User Manual

ORIGINAL DOCUMENT
Manual Revision 2.2

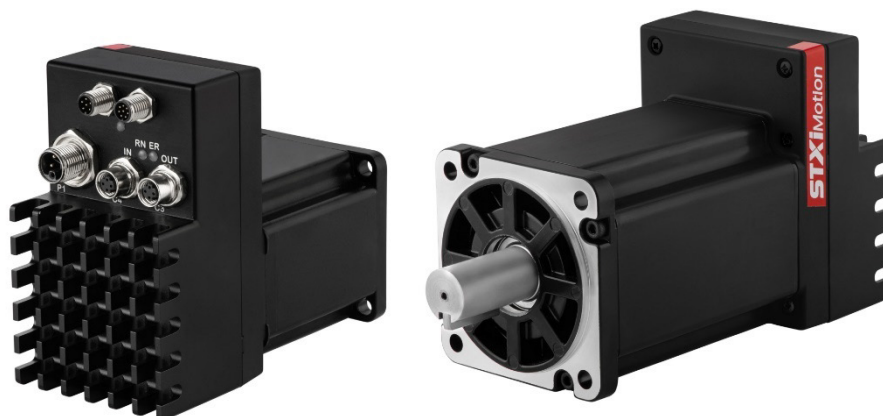

Revision History

Manual Rev.	Date	Notes
Rev.2.2	17 Feb.2026	Added trademark logos. Added FsoE version to Ordering Info. Added Dimensions tables and diagrams: TIM models IM1 60S / 60M – with All Feedback Types and TIM models IM1 80S / 80M – with All Feedback Types Added Digital Inputs/ Digital Outputs circuitry. Added Fuses Wiring section. Updated description of Fault #83.
Rev.2.1	12 Nov. 2025	Corrected pinouts for Fieldbus C3 and C4 (pins 3 and 4).
Rev.2.0	6 Nov. 2025	Manual updated with descriptions and instructions for Motion Suite software. Added chapters <i>Motion Suite Software Overview</i> and <i>Advanced Operation</i> , and <i>Tuning the Control Loop</i> . Replaced chapter <i>Commissioning</i> with <i>TIM Motor Setup</i> . Updated chapters <i>Warnings and Faults</i> and <i>Motor Brake Control</i> . Firmware version: 21.10.9.x Motion Suite software version: 1.2.27.xx
Rev.1.5	5 Aug. 2025	Updated Electrical Safety (power supply). Updated Warnings and Faults.
Rev.1.4	28 Apr. 2025	Added new chapter (10): Overload Protection.
Rev.1.3	4 Nov. 2024	Updated Ordering Info. Additions and updates to Warning and Faults chapter. Reorganized content: Updated Installation chapter; added Commissioning the Drive chapter. Added note to Firmware Upgrade chapter.
Rev.1.2	18 July 2024	Updated dimensions drawings. Updated product label.
Rev.1.1	16 July 2024	Corrected descriptions for interfaces C1 and C2 in Chapter 6.
Rev.1.0/1.0a	11 July 2024	Initial release.

Copyright Notice

© 2026 STXI Motion Ltd.

All rights reserved. No part of this work may be reproduced or transmitted in any form or by any means without prior written permission of STXI Motion Ltd.

Disclaimer

This product documentation was accurate and reliable at the time of its release. STXI Motion Ltd. reserves the right to change the specifications of the product described in this manual without notice at any time.

Trademarks



TIM is a trademark of STXI Motion Ltd.



CANopen® and CiA® are registered trademarks of CAN in Automation e.V. (CiA)



EtherCAT® and Safety over EtherCAT® are registered trademarks and patented technologies, licensed by Beckhoff Automation GmbH, Germany.

Windows® is a registered trademark of Microsoft Corporation.

Contact Information

www.stxim.com

contact@stxim.com

CANopen Vendor-ID

Vendor-ID 0x00000513 has been registered to STXI Motion Ltd.

EtherCAT Vendor-ID

Vendor-ID 0x00000D2B has been registered to STXI Motion Ltd.

Contents

1	Introduction	7
1.1	Product Description	7
1.2	Ordering Info	8
1.3	Product Label	9
1.4	Product Documentation	10
2	Standards Compliance	11
3	Safety	12
3.1	Safety Symbols	12
3.2	Safety Guidelines	12
3.3	Intended Use	13
3.4	Installation Safety	14
	Thermal Safety	14
	Electrical Safety	14
	Functional Safety	15
4	Handling and Storage	16
4.1	Transporting	16
4.2	Packaging	16
5	Specifications	17
5.1	Motor Power	17
	Speed/Torque Curves	18
5.2	Feedback and Control	21
5.3	Inputs/Outputs	21
5.4	Communication	22
5.5	Mechanical	22
	Weight	22
	Dimensions	23
5.6	Environmental	27
5.7	Drive Protection	27
6	Installation	28
6.1	System Design	28
6.2	Setup Overview	28
6.3	Wiring Guidelines	29
6.4	Grounding	29
6.5	Fuses Wiring	30
6.6	Electrical Interfaces	31
	P1 – Power	31
	C1 – Digital I/Os	32
	C2 – STO-Brake-RS232	33
	C3 – Fieldbus OUT – CANopen/EtherCAT	35
	C4 – Fieldbus IN – CANopen/EtherCAT	36
6.7	Communication Cabling	37
	Serial Cabling	37
	CANopen/EtherCAT Cabling	38
6.8	Computer System	38
6.9	Fieldbus Devices (CANopen/EtherCAT)	39
6.10	Motion Suite Software	39
6.11	Power Up and Establish Communication	40

7	Motion Suite Software Overview	41
7.1	Screen Elements	41
	Motion Suite Toolbar	41
	Navigation Pane	43
	Task Screens	43
	Status Bar	43
7.2	Communication Settings	44
7.3	Basic Operation – Motion Suite Dashboard	45
	Status Monitor	45
	Movement Modes and Command Execution	46
	Chart	47
7.4	Parameters	48
8	TIM Motor Setup	51
	Confirm TIM Settings and System Units	51
	Test the Motor Response to a Torque Command	53
9	Tuning the Control Loop	55
	Turn Off All Velocity Filters	55
	Tune the Gains in Velocity Loop	56
	Test the Position Loop	60
	Optimize the Position Error	61
	Save the Control Parameters to the Drive	62
10	Advanced Operation	63
10.1	Motion Modes and Execution	64
10.2	Recording Setup and Activation	65
10.3	Recording Charts	67
10.4	Parameter Monitoring and Analysis	69
10.5	Terminal	70
10.6	Scripts	71
11	Network Communication	72
11.1	CANopen Network	72
	CANopen Network Management	72
	CANopen Node ID	72
	CANopen Baud Rate	73
11.2	EtherCAT Network	73
	EtherCAT Address	73
	EtherCAT Network Management	73
12	Motor Brake Control	75
12.1	PWM Motor Brake Control Overview	75
12.2	BrakeType 1 (Open-Loop)	76
	Brake Current Behavior	76
	Duty Cycle Settings	77
	Parameter Settings	77
12.3	BrakeType 2 (Closed-Loop)	78
	Advantages of PWM Brake Control	78
	Important Considerations	79
	Brake Current Reference	79
12.4	Additional Motor Brake Parameters	82
	Brake Support	82
	Brake Hold Time	82
	Brake Release Time	83

IBrake.....	83
12.5 Motor Brake Parameters Summary	83
12.6 Holding Brake Data.....	84
13 Overload Protection.....	86
14 Digital Inputs and Outputs.....	88
14.1 Serial	88
Digital Inputs	88
Digital Outputs	89
14.2 CANopen/EtherCAT	90
Digital Inputs – CANopen.....	90
Digital Outputs - EtherCAT	90
15 Firmware Upgrade.....	91
Firmware Upgrade via RS232/Motion Suite.....	91
16 Troubleshooting.....	93
16.1 LEDs.....	93
Link Activity Status – LEDs C4 and C3 – EtherCAT only.....	93
Drive Status – Tri-colored LED – CANopen and EtherCAT	93
Run Status – RN – CANopen.....	94
Error Status – ER – CANopen	94
Run Status – RN – EtherCAT.....	95
Error Status – ER – EtherCAT	95
16.2 Faults and Warnings.....	96
Faults and Warnings Screen.....	96
Faults and Warning Codes.....	98

1 Introduction

1.1 Product Description

The TIM is an integrated servo motor – consisting of motor, drive electronics, power stage and position sensor all in one unit. The TIM has digital I/Os, CANopen, EtherCAT and RS232 communication channels, and supports absolute single turn and multiturn encoders.

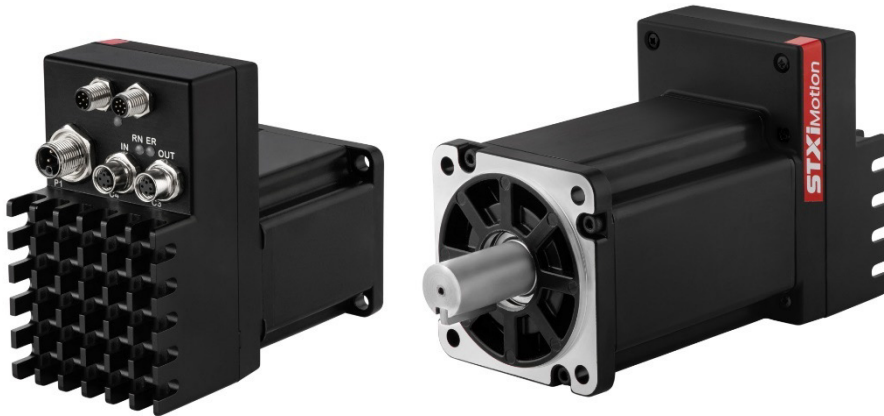

Figure 1-1 TIM integrated servo motor

1.2 Ordering Info

The following table shows the ordering options that comprise the various model numbers of the integrated servo motors in the TIM product line. To enquire about custom options, contact STXI Motion.

Table 1-1. Product Ordering Options

		IM1	-	60S	4	3	2	5	EC	20	0	00
	Integrated Servo Motor											
	Frame Size and Length											
60S	Flange 60 mm Short (200 W)											
60M	Flange 60 mm Medium (400 W)											
80S	Flange 80 mm Short (480 W)											
80M	Flange 80 mm Medium (800 W)											
	DC Bus Voltage											
2	24 VDC (60 mm motors only)											
4	48 VDC											
	Rated Speed											
3	3000											
	Shaft											
0	Smooth											
2	Keyway											
	Connector and Protection Class											
1	Connector front mounting IP54 (<i>upon request only</i>)											
5	Connector back mounting IP 54											
6	Connector top mounting IP 54											
	Communication											
CO	CANopen											
EC	EtherCAT											
ES	FSoE (Fail Safe over EtherCAT) – Safe Version											
	Feedback											
20	Absolute single turn 21-bit											
30	Absolute multiturn 24-bit											
	Brake											
0	No brake											
B	With brake											
	Option											
00	–											

1.3 Product Label

The product label is attached to the side of the TIM integrated servo motor.

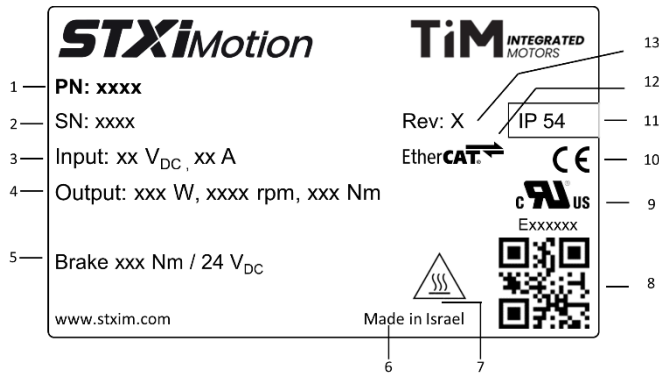

Figure 1-2. Product label on TIM

Item	Description
1	Part number
2	Product serial number
3	Nominal input
4	Nominal output
5	Brake type (if TIM has brake)
6	Country of manufacturer
7	Hot surface
8	Identification code
9	UL compliance
10	CE compliance
11	Protection class
12	Fieldbus
13	Hardware revision

1.4 Product Documentation

This documentation describes the TIM integrated servo motor.

It provides the information required for installation and configuration of the TIM.

This documentation is intended for persons who are qualified to assemble, commission, and maintain the equipment described herein.

Before you install the TIM, review the instructions in this manual. Pay particular attention to all safety instructions and warnings. Failure to follow the safety instructions may result in personal injury or equipment damage.

This manual is part of a documentation set, which consists of the following:

- *TIM User Manual*. Hardware installation, configuration and tuning.
- *TIM and ZED EtherCAT/CANopen Reference Manual*. Implementation of EtherCAT and CANopen protocol in TIM.
- *TIM and ZED Safety User Manual / TIM and ZED STO Safety User Manual*

2 Standards Compliance

The TIM has been designed and manufactured according to the standards specified in the following table. Testing and certifications are pending.

Table 2-1. Standards Compliance





Topic	Directive	Standard(s)
Thermal and Electrical Safety	EU Low Voltage Directive 2014/35/EU	EN IEC 61800-5-1
Electromagnetic Compatibility	EMC Directive 2014/30/EU	EN IEC 61800-3 EN IEC 61000-6-7
Functional Safety	Machinery Regulation EU 2023/1203	EN IEC 61508, Parts 1–7 EN IEC 61800-5-2 EN ISO 13849, Parts 1–2
RoHS	RoHS Directive 2011/65/EU	EN IEC 63000
REACH	<i>TBD</i>	<i>TBD</i>

3 Safety

3.1 Safety Symbols

The following safety symbols are used on the drive and in this manual.

Table 3-1. Safety Symbols

Symbol	Meaning	Description
	Dangerous voltage	Indicates a hazardous situation, which, if not avoided, will result in death or serious injury.
	Caution	Indicates a hazardous situation, which, if not avoided, could result in injury or equipment damage.
	Functional earthing	Identifies a functional earthing (grounding) terminal or conductor, which serves to ensure proper functioning of electronic equipment.
	Caution, hot surface	Indicates the marked item can be hot, and should not be touched without taking care.

3.2 Safety Guidelines

- Before installing or commissioning the TIM, review all relevant product documentation.
- Install and operate the system according to the instructions in this manual.
- Only qualified personnel may perform installation, operation, service, and maintenance procedures. These persons must have sufficient technical training and knowledge to foresee and recognize potential hazards that may occur when using the product, modifying settings, and operating the mechanical, electrical, and electronic components of the entire machine system.
- All persons working on and with the product must be fully familiar with all applicable standards, directives, and accident prevention regulations when performing such work.
- Failure to follow the safety instructions may result in personal injury or equipment damage.

3.3 Intended Use

The TIM integrated servo motor is intended for use as a component within a machine system.

- The machine builder and integrator must ensure the protection of both personnel and the complete machine system.
- The machine builder and/or integrator must perform a risk assessment in view of using the TIM integrated servo motor in the intended application. Based on the results, the appropriate safety measures must be implemented.
- The TIM integrated servo motor must be used in compliance with all applicable safety regulations and directives, and all technical specifications and requirements.
- The machine builder and the machine owner are responsible for the safety of the machine operators.
- The machine owner and the machine operator are responsible for ensuring personnel cannot enter the hazard zone while the machine is energized unless adequate functional safety mechanisms are in place.

3.4 Installation Safety



Incorrect handling of the TIM may cause personal injury and/or damage to equipment.

Perform the installation in strict compliance with product specifications and installation instructions.

Thermal Safety

- During continuous motor operation, the motor body and drive heat up.
- To prevent damage to the product, ensure the temperatures of the TIM components remain at least 5°C below their threshold (fault) limits:
 - Drive CPU: 115°C
 - Heat sink: 90°C
 - Motor: 120°C
- Motion Suite software reads and reports the temperatures of the drive CPU and the heatsink. It also reports the motor temperature if the motor has a sensor, as defined by the serial parameter **MotorTempSensor**.
- System temperature values can be read from object 2021h (sub-indices 1-6).
- Install the TIM in a manner that allows proper air flow.
- The TIM is rated for use at altitudes up to 2000 meter above sea level.

Electrical Safety

- **TIM power supply.**

The power supply shall be an ES1 (SELV/PELV) power supply per EN/IEC 62368-1. The nominal output voltage shall be no more than 48VDC.

The power supply output shall be guaranteed to not exceed 60VDC in the event of a single failure in the power supply.

The power supply shall switch itself off if the output voltage exceeds 60VDC (as might happen in the case of unexpected regeneration voltage).



Warning. The use of unsuitable power supply units that are not SELV/PELV can lead to dangerously high voltages in the event of a fault.

- As part of the machine design, the machine builder must generate a hazard analysis for the machine and take appropriate measures to ensure that unforeseen movements cannot cause personal injury and/or damage to equipment.

Functional Safety

The safety functions listed below have been implemented in the TIM.

TIM units can be ordered with STO only, or with a safety motion module (SMM) that provides all the listed safety functions.

For details, refer to *TIM and ZED Safety User Manual* or *TIM and ZED STO Safety User Manual*, as applicable.

Function	Description
STO	Safe torque off
SS1-t	Safe stop 1 time controlled
SS1-r	Safe stop 1 deceleration ramp monitored
SBC	Safe brake control
SOS	Safe operating stop
SLS	Safely-limited speed
SS2-t	Safe stop 2 time controlled
SS2-r	Safe stop 2 deceleration ramp monitored
SSR	Safe speed range
SLA (SAR)	Safely-limited acceleration (safe acceleration range)
SLP	Safely-limited position
SLI	Safely-limited increment
SSM	Safe speed monitor
SDI	Safe direction

4 Handling and Storage

4.1 Transporting

Transport the TIM integrated servo motor in its original packaging materials.

Avoid transporting the TIM in conditions which may cause strong vibrations of the drive, or impact with other objects.

4.2 Packaging

The package contains the TIM integrated servo motor only.

Upon receipt, open the package and remove all packing materials.

Check to ensure there is no visible damage to the TIM integrated servo motor. If damage is detected, notify the carrier immediately.

After unpacking, check the part number label on the product. Make sure it matches the product you ordered, and that the voltage meets your specific requirements.

Save the original box and packing materials in case you need to pack and return the product to the manufacturer.

5 Specifications

5.1 Motor Power

Table 5-1. Motor Power Specifications

Feature	Unit	IM1-60S	IM1-60M	IM1-60S	IM1-60M	IM1-80S	IM1-80M
Input Voltage	VDC	24		48			
Flange Size	mm	60	60	60	60	80	80
Power Rating	W	200	400	200	400	480	800
Rated Current	A	11	22	6.50	12	14.60	22
Peak Current	A	32.40	66	19.50	36	46	66
Rated Torque	Nm	0.64	1.27	0.64	1.27	1.53	2.55
Peak Torque	Nm	1.92	3.81	1.92	3.81	4.60	7.60
Rated Speed	rpm	3000					
No Load Speed	rpm	4200	4200	5400	5000	5100	4800
Brake Voltage	VDC	24 ±10%					
Brake power	W	7.4				13.5	
Holding torque	Nm	1.3				4	

Speed/Torque Curves

IM1-60S – 24 VDC, 200 W

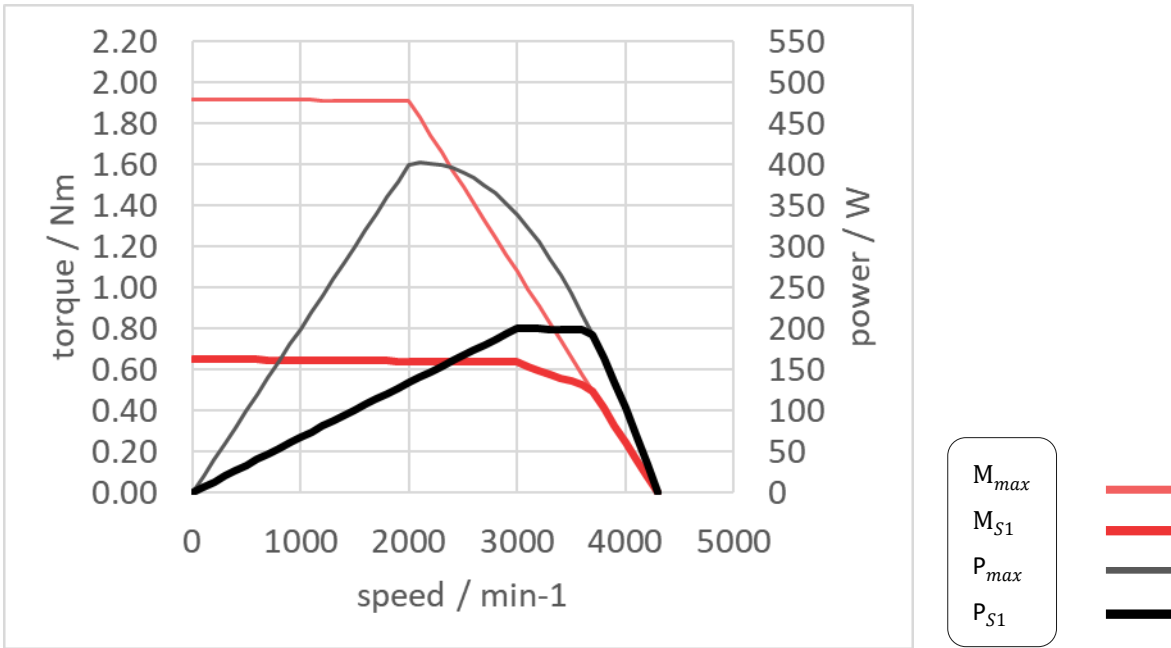

IM1-60S – 48 VDC, 200 W

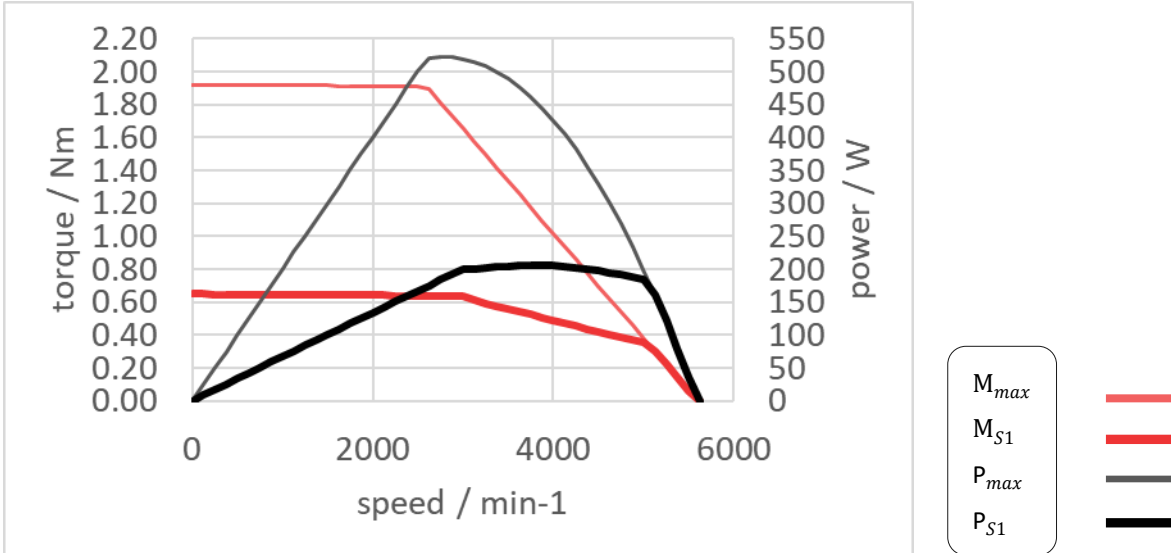

IM1-60M – 24 VDC, 400 W

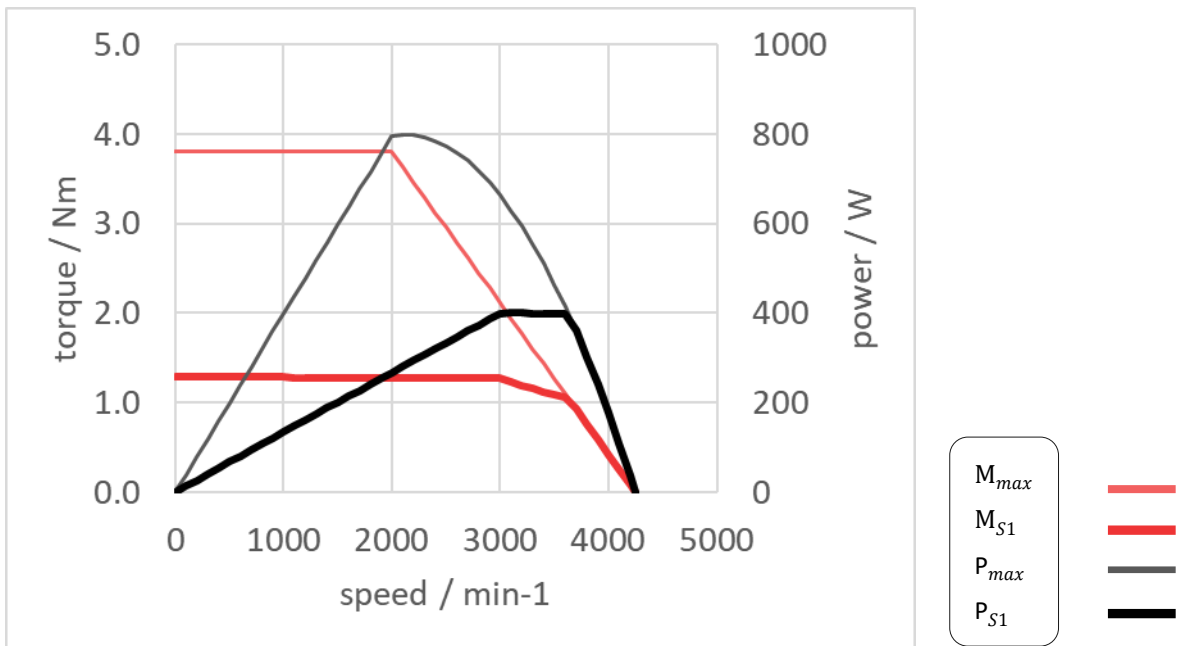

IM1-60M – 48 VDC, 400 W

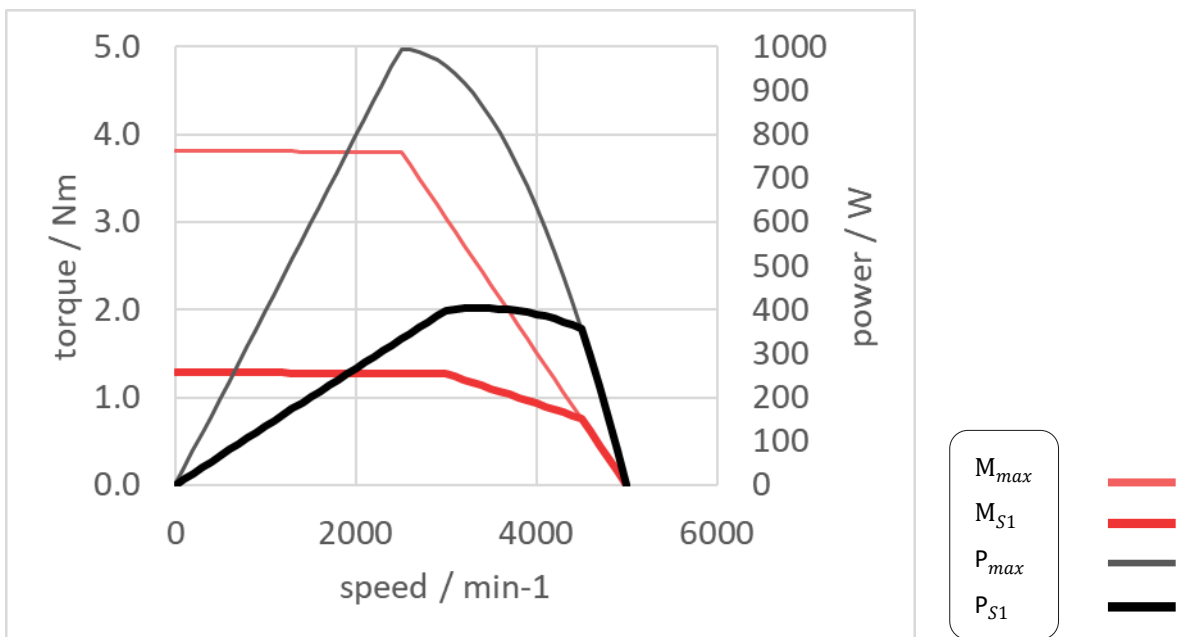

IM1-80S – 48 VDC, 480 W

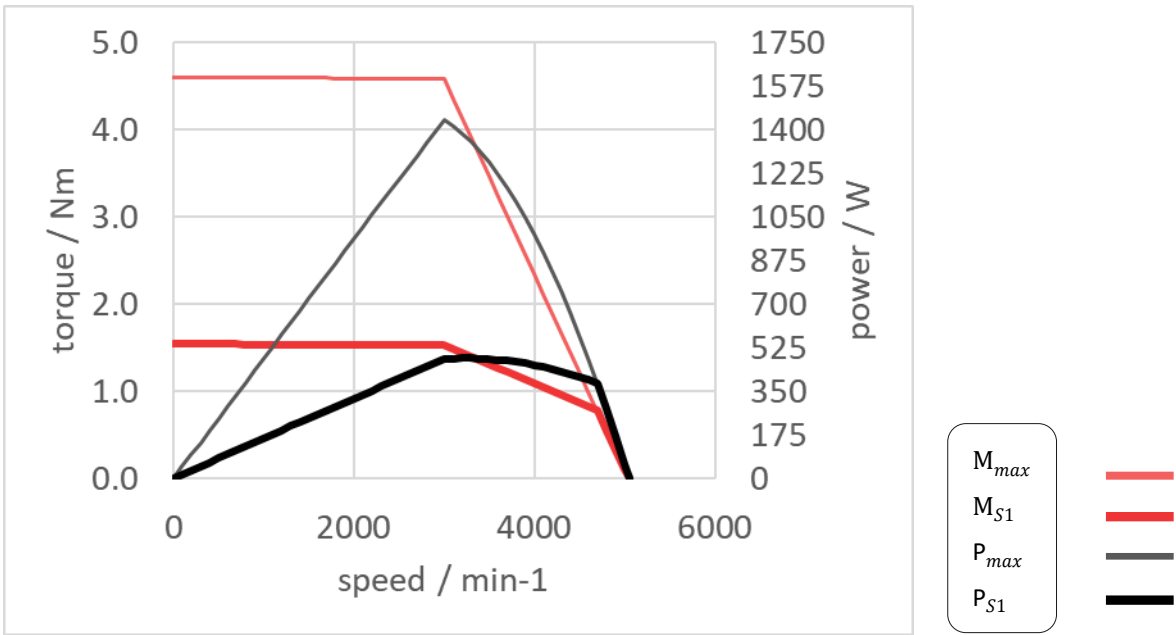

IM1-80M – 48VDC, 800 W

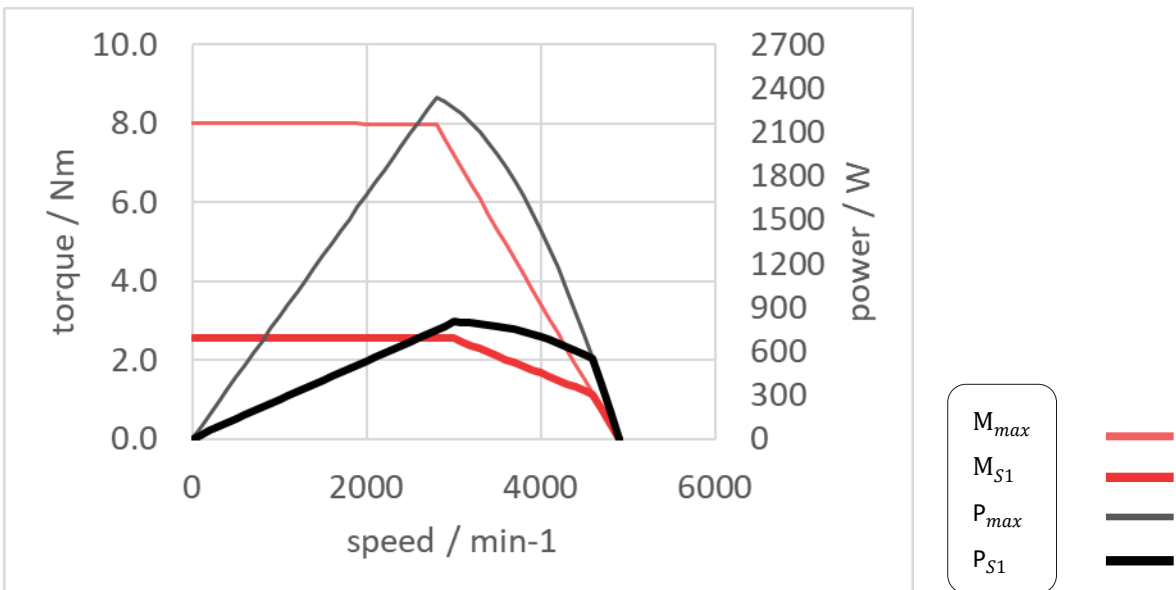

5.2 Feedback and Control

Table 5-2. Feedback and Control Specifications

Feature	Specification	
Operation Modes	Selectable	Profile position Profile velocity Homing Types: 17, 18, 19, 20, 21, 22, 23, 24, 27, 28, 37 Cyclic synchronous position
Display		LEDs
Software Tools	User Interface	Motion Suite, Windows-based
	Functions	Connection settings, Drive info, Power info, I/O configuration, Motion settings and tuning, Fault history/display
Feedback		Absolute single turn, Absolute multi turn

5.3 Inputs/Outputs

Table 5-3. Inputs/Outputs Specifications

Feature	Specification	
3x Digital Input	Signal	Configurable opto-isolated, sink/source, Types: 1 and 3
	Functions	Multi-functional, user-definable: home switch, positive limit switch, negative limit switch.
	Voltage High Level Input	30 V
	Min. High Level Input	11 V
	Max. Low Level Input	5 V
	Input Resistance	3.6 k Ω
	Max. Input Frequency	5 kHz
	Propagation Delay Time	200 μ s
1x Digital Output	Signal	Configurable open collector, opto-isolated sinking output
	Functions	Multi-functional, user-definable: drive disabled, drive enabled.
	Voltage	30 V
	Max. Current	100 mA
	Min. Load Resistance	300 Ω
	Output Voltage	2 V
	Min. Propagation Delay Time	1 ms (may be longer if load current is lower)

5.4 Communication

Table 5-4. Communication Specifications

Feature	Specification
CANopen	CANopen – CiA 301 application layer and CiA 402 device profile for drives and motion control. Baud rate 10 kbps – 1 Mbps CAN ID 1 – 127 (Default 127) Heartbeat producer, SDO, PDO (dynamic mapping)
EtherCAT	CANopen over EtherCAT (CoE) – CiA 301 application layer and CiA 402 device profile for drives and motion control. Communication cycle time: up to 250 μ s.
RS232	Serial communication for configuration

5.5 Mechanical

Weight

Table 5-5. TIM with Single Turn Feedback

Feature	Unit	IM1 60S	IM1 60M	IM1 80S	IM1 80M
Weight, without brake	kg	0.98	1.32	1.68	2.20
Weight, with brake	kg	1.24	1.58	2.40	2.86

Table 5-6. TIM with Absolute Multiturn Feedback

Feature	Unit	IM1 60S	IM1 60M	IM1 80S	IM1 80M
Weight, without brake	kg	1.10	1.45	1.80	2.35
Weight, with brake	kg	1.35	1.70	2.52	3.00

Dimensions

Table 5-7. TIM models IM1 60S / 60M – with Absolute Encoder

Part Number	Power (W)	Length (mm) with Absolute Single turn Encoder	Length (mm) Absolute Multiturn Encoder
IM1-60SX3X5XXYY000	200	104.3	124.3
IM1-60SX3X5XXYYB00	200 with brake	121.3	141.3
IM1-60MX3X5XXYY000	400	124.3	144.3
IM1-60MX3X5XXYYB00	400 with brake	141.3	161.3

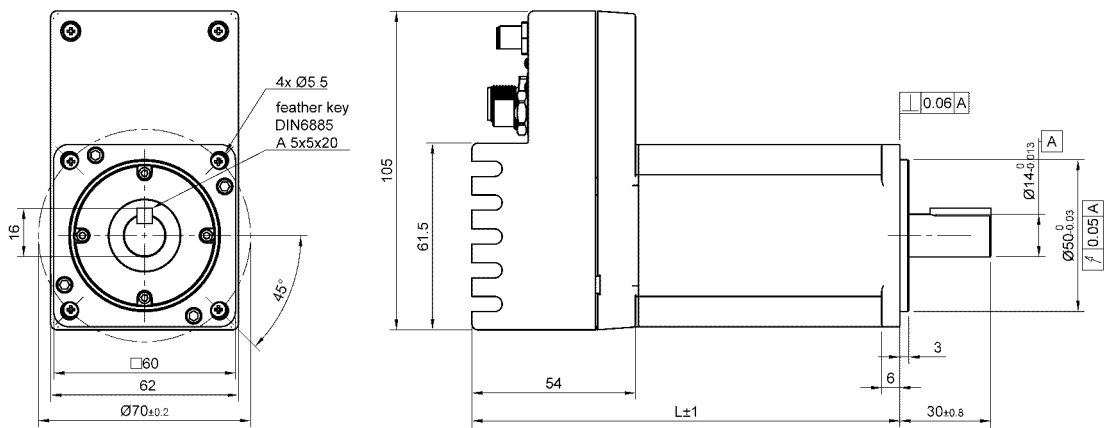

Figure 5-1. Dimensions - TIM models IM1 60S / 60M – with Absolute Encoder

Table 5-8. TIM models IM1 60S / 60M – with All Feedback Types

Part Number	Power (W)	Length (mm) with All Feedback Types
IM1-60MX3X6XXYYB00	400 with brake	114.5
IM1-60MX3X6XXYYB0R	400 with reinforced brake	123.5

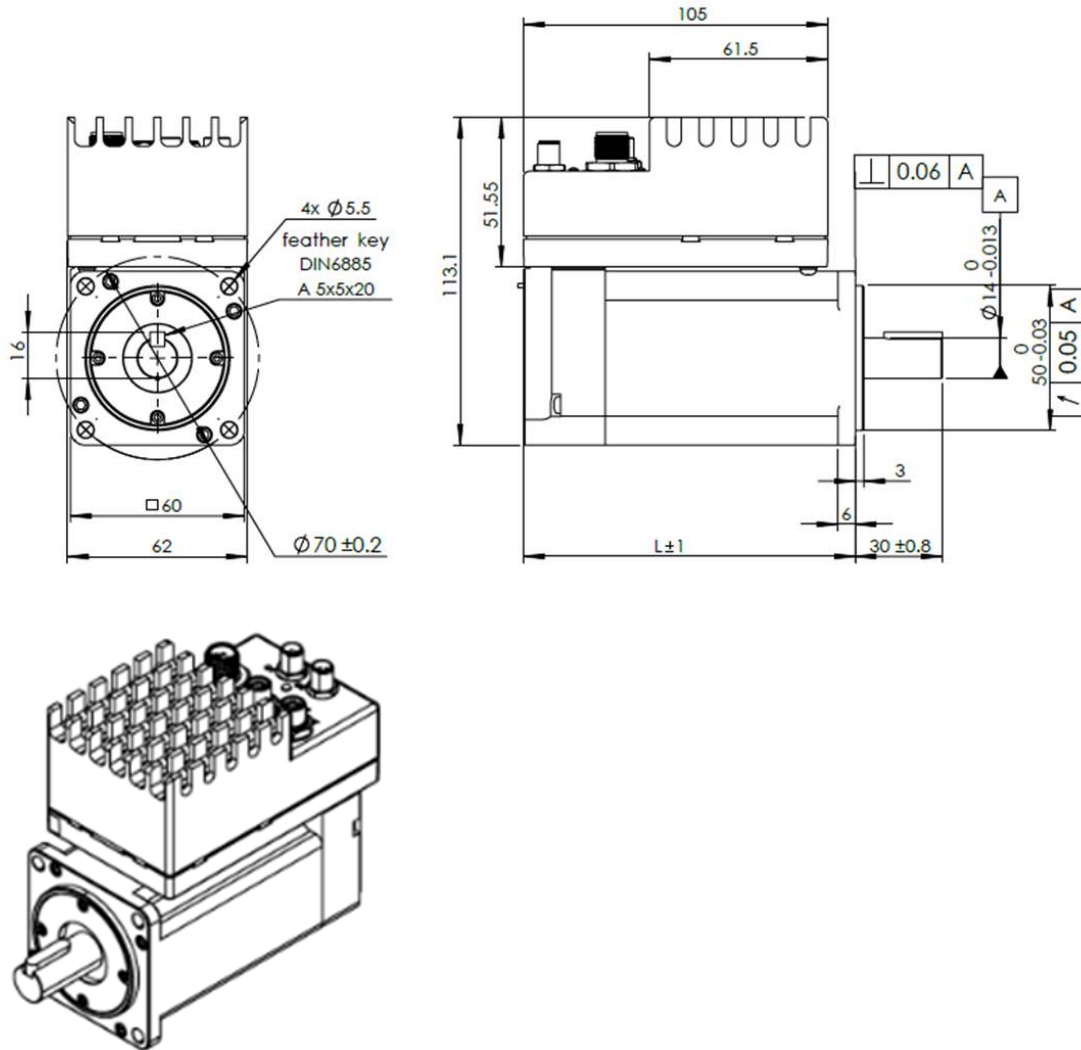

Figure 5-2. Dimensions - TIM models IM1 60S / 60M – with All Feedback Types

Table 5-9. TIM models IM1 80S / 80M

Part Number	Power (W)	Length (mm) with Absolute Single turn Encoder	Length (mm) Absolute Multiturn Encoder
IM1-80SX3X5XXXX000	480	113.25	133.25
IM1-80SX3X5XXXXB00	480 with brake	143.25	163.25
IM1-80MX3X5XXXX000	800	130.25	150.25
IM1-80MX3X5XXXXB00	800 with brake	160.25	180.25

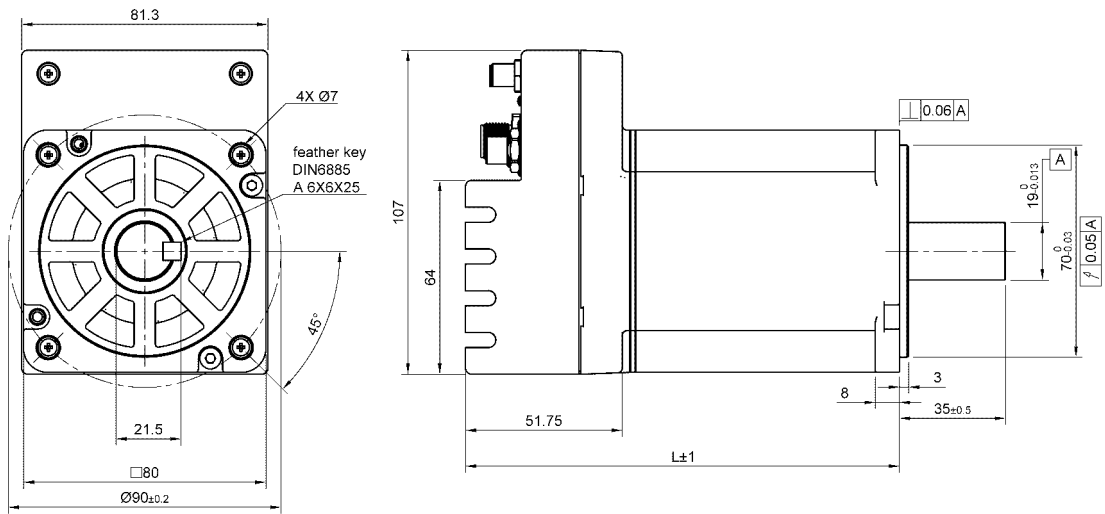

Figure 5-3. Dimensions TIM models I M1 80S / 80M – with Absolute Encoder

Table 5-10. TIM models IM1 60S / 60M – with All Feedback Types

Part Number	Power (W)	Length (mm) with All Feedback Types
IM1-80SX3X6XXYY000	480	93.7
IM1-80MX3X6XXYYB00	800 with brake	140.7

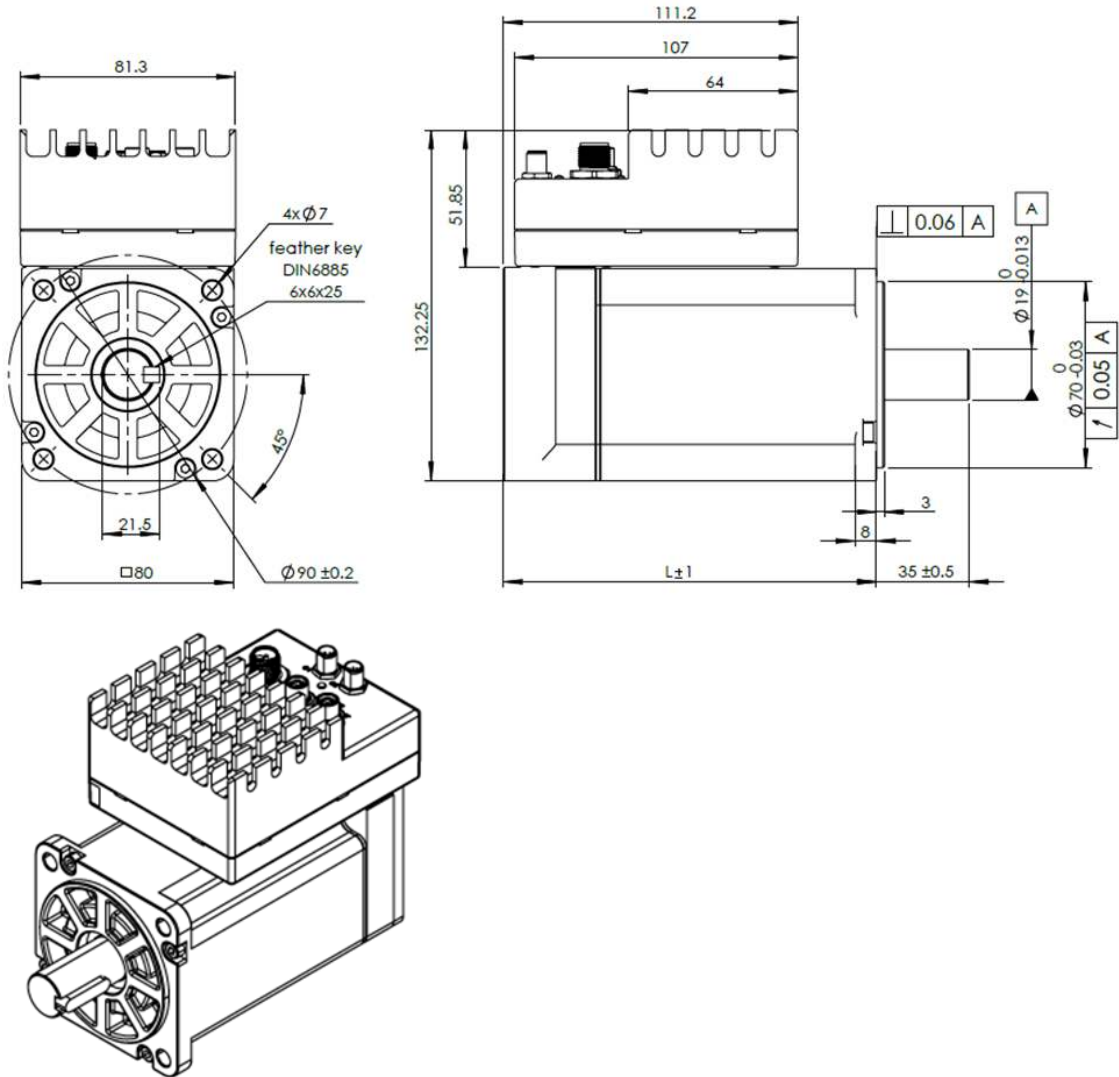

Figure 5-4. Dimensions - TIM models IM1 80S / 80M – with All Feedback Types

5.6 Environmental

The TIM has been designed and manufactured according to the standards specified in the following table. Testing and certifications are pending.

Table 5-11. Environmental Specifications

Feature	Specification
Environment	Ambient temperature: Operation: 0 – 40°C Storage: 0 – 70°C
	Humidity: 10 – 90%
	Altitude: <2,000 m (per EN IEC 61800-5-1)
	Vibration: 1g sine vibration from 10 Hz to 150 Hz (per EN IEC 61800-5-1)
	Shock: 5g half-sine for 30 m (per EN IEC 61800-2)
Operating Conditions	Protection class: IP54

5.7 Drive Protection

Table 5-12. Protection Specifications

Feature	Specification
Protective Functions	Overload limit, Over-voltage, Over-current, Under-voltage, Drive over-temperature, Over-speed, Velocity error, Position error, PLL lock lost, Position following error.

6 Installation

6.1 System Design

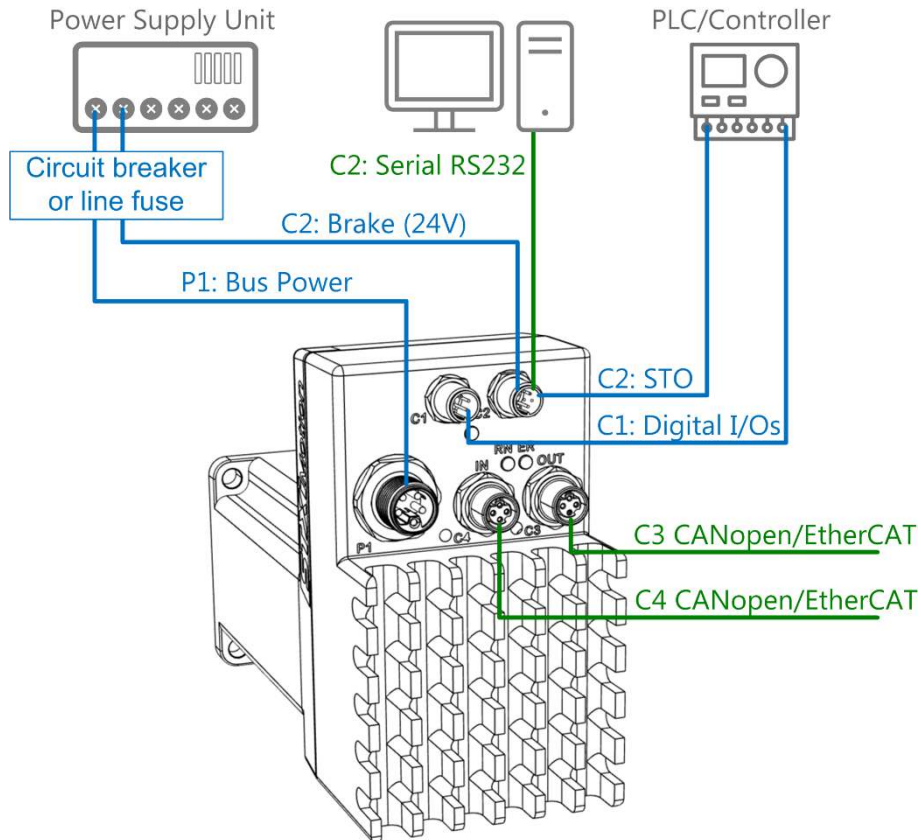

Figure 6-1 System Design

6.2 Setup Overview

Perform the following steps to install a TIM system.

1. Mount the TIM.
2. Make all wiring and cable connections, as required by your application:
 - DC bus voltage (P1)
 - CANopen/EtherCAT (C3, C4)
 - Digital inputs, digital outputs (C1)
 - Brake, STO, RS232 (C2)
3. Connect the TIM to the PLC and/or the PC (C4).
4. Power up the TIM and the PC.
5. Download and install Motion Suite for TIM on the PC, and use it to configure and test the TIM.

6.3 Wiring Guidelines

To ensure optimal performance, wire your system in accordance with the following guidelines:

- To reduce the effects of EMI, the following cables are recommended:
 - Power supply – shielded cables
 - CANopen/EtherCAT communication – twisted pairs and shielded cables
- Twisting must be maintained as close as possible to both ends of the cable.
- Shielding must be maintained at both ends of the cable.
- If connecting the power supply unit (PSU) to more than one TIM, use either a star or a bus connection, as shown in the following figures.

When using a bus connection, be sure to select an appropriate wire gauge if minimal drive voltage is crucial.

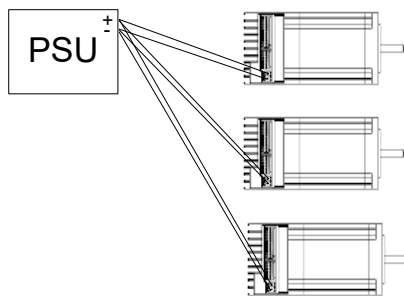

Figure 6-2. Star Connection

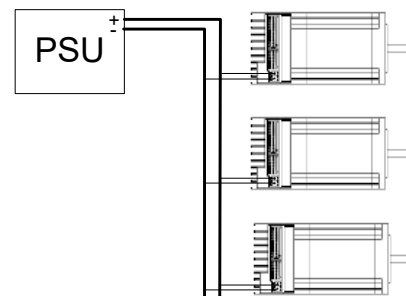

Figure 6-3. Bus Connection



Warning: Do not daisy chain input voltage from one TIM to the next.

6.4 Grounding

When connecting the TIM to other control equipment, be sure to follow two basic guidelines for proper functioning of the drive:

- The TIM should be grounded via functional earth ground (FE) of the voltage supply.
- Any motion controller, PLC or PC that is connected to the TIM must be grounded to the same earth ground as the TIM.

For more details, refer to the section *Electrical Safety* in Chapter 3 of this manual.

6.5 Fuses Wiring

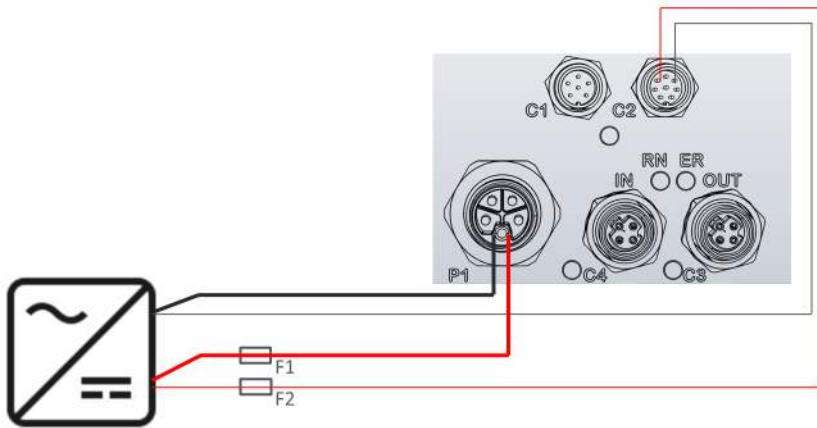
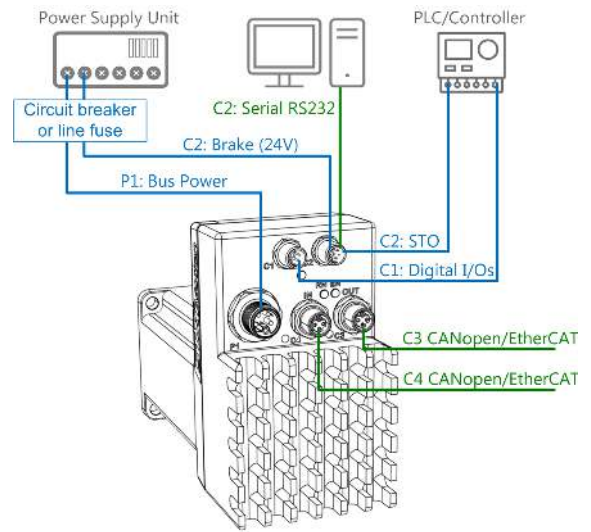

Figure 6-4. Fuses Wiring

Table 6-1. Fuses Wiring

Fuse	External Input Fuse	Specification	Connector on Drive
F1	Power Supply	30 A	P1
F2	Brake Supply	1 A	C2

6.6 Electrical Interfaces

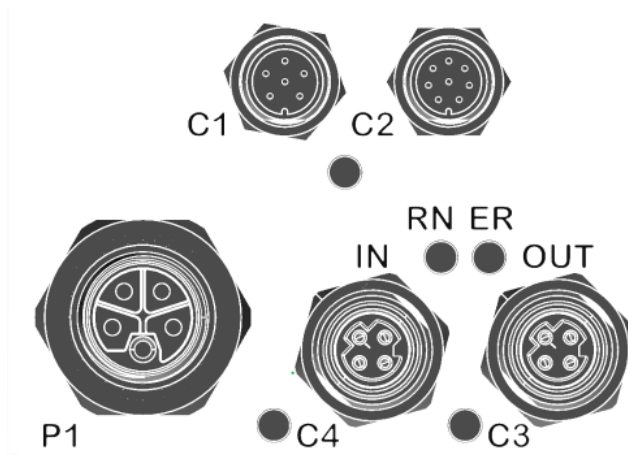

Figure 6-5 Interfaces

P1 – Power

Table 6-2. P1 Connectors

Interface	Item	Manufacturer	Manufacturer Part Number
	Connector M12 Male, 5-pin, L-coded	TE Connectivity	T4140L12051-000
	Mating Cable Power cable, 5-position, PUR, Length: 1.5 m AWG 14 or AWG 16	TE Connectivity	TE: T4151399L25-002 STXI: CBL-M1205PW-01

Table 6-3. P1 Pinout

Pin #	Signal Description
1	Vpower Power In+
2	Vpower Power In+
3	Vpower Power Ret -
4	Vpower Power Ret -
5	Functional earth (FE)

C1 – Digital I/Os

Table 6-4. C1 Connectors

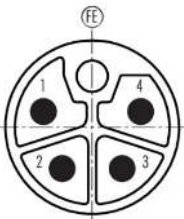
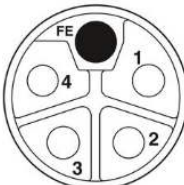
Interface	Item	Manufacturer	Manufacturer Part Number
	Connector M8 Male, 6-pin	Finecables	MB08MBAFF06ST
	Mating Cable M8 Female, Molded cable, Straight, Shielded	Finecables	FC: MA08FSAF06ST10CB14 STXI: CBL-M0806ACO-01

Table 6-5. C1 Pinout

Pin #	Signal Description
1	DIN 1
2	DIN 2
3	DIN 3
4	Out Com
5	DOUT 1
6	In Com

C2 – STO-Brake-RS232

Table 6-6. C2 Connectors

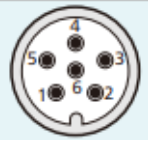
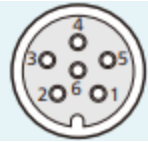
Interface	Item	Manufacturer	Manufacturer Part Number
 (A-coding)	Connector. M8 Male, 8-pin	Finecables	MB08FBAFF08ST
 (A-coding)	Mating Cable. M8 Female, Molded cable, Straight, Shielded	Finecables	MA08MSAF08STXXCB14 (XX = length)

Table 6-7. C2 Pinout

Pin #	Signal Description
1	STO_1
2	RS232 Rx
3	RS232 Tx
4	V_Brake
5	GND_Brake
6	STO GND
7	STO_2
8	RS232 GND

This following sections describe the regular digital I/Os for the TIM drive.

Digital Inputs Circuitry

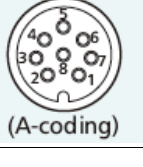
Wire the digital and analog inputs and outputs according to the requirements of your application. Unused pins must remain unwired.

Sourcing digital input. Wiring involves connecting a sensor or a switch that supplies +24VDC to the input module. The input common terminal connects to ground (0 VDC); when the field device closes, it sends positive voltage (current) to the input channel.

Sinking digital input. The device receiving the input signal does not provide power. It must be connected to a sinking output with a power supply loop or a sourcing output or a sinking output.

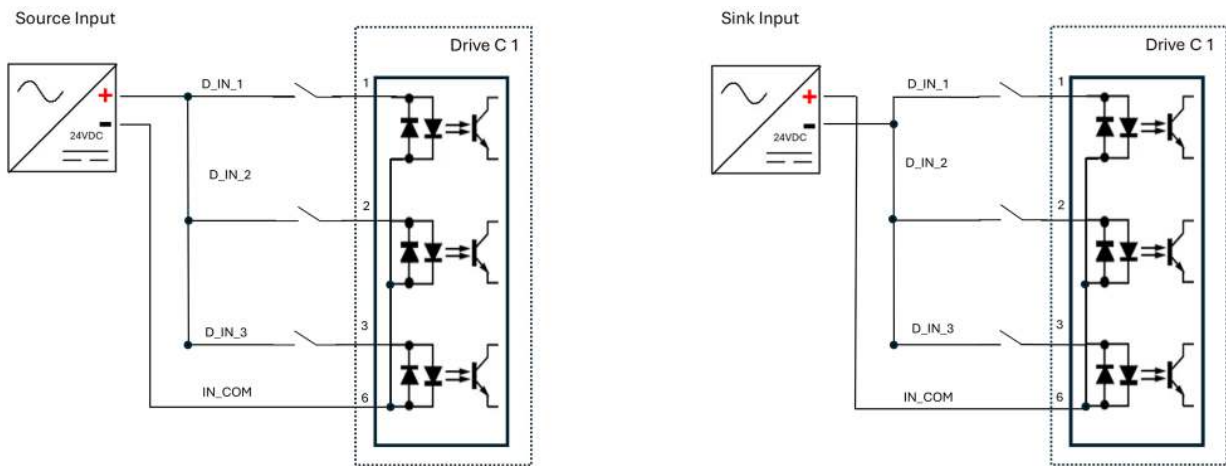

Figure 6-6. Digital inputs circuitry – sourcing and sinking

Digital Output Circuitry

Sourcing digital output. A digital circuit that acts as a power source, providing voltage to an external load.

Sinking digital output. Connects the load to ground when active, requiring the load to be wired between the positive power supply (+VDC) and the output terminal.

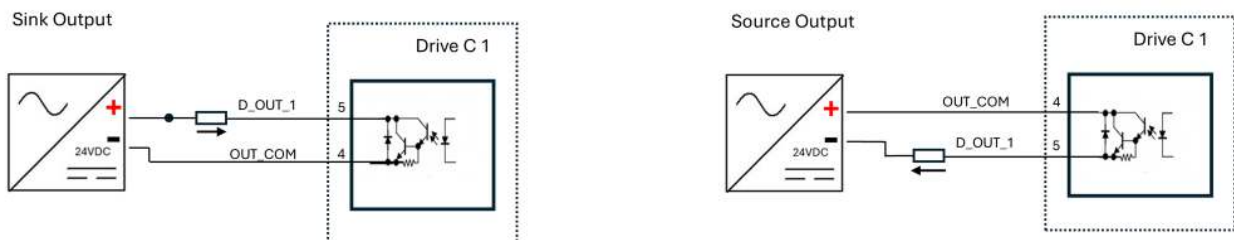

Figure 6-7. Digital outputs circuitry – sourcing and sinking

C3 – Fieldbus OUT – CANopen/EtherCAT

Table 6-8. C3 Connectors

Interface	Item	Manufacturer	Manufacturer Part Number
	Connector M8 Female, 4-pin D-coded	Finecables	A838-CP-T0316
	Mating Cable M8 Male, 1 m Molded cable, Straight, Shielded, D-coded	Finecables	M8 to M8: FC: MA08MSDF04STx2-10CB25 STXI: CBL-M8M8ECD-001 M8 to RJ45: FC: MA08MSDF04ST10CB25-RJ45 STXI: CBL-M8RJ45D-001)

Table 6-9. C3 Pinout

Pin #	CANopen	EtherCAT
1	CAN_H	ECAT_OUT_Tx+
2	CAN_GND	ECAT_OUT_Rx+
3	CAN_L	ECAT_OUT_Rx-
4	CAN_GND	ECAT_OUT_Tx-

C4 – Fieldbus IN – CANopen/EtherCAT

Table 6-10. C4 Connectors

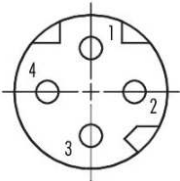
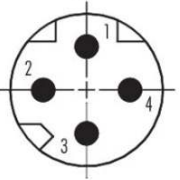
Interface	Item	Manufacturer	Manufacturer Part Number
	Connector M8 Female, 4-pin D-coded	Finecables	A838-CP-T0316
	Mating Cable M8 Male, 1 m Molded cable, Straight, Shielded, D-coded	Finecables	M8 to M8: FC: MA08MSDF04STx2-10CB25 STXI: CBL-M8M8ECD-001 M8 to RJ45: FC: MA08MSDF04ST10CB25-RJ45 STXI: CBL-M8RJ45D-001)

Table 6-11. C4 Pinout

Pin #	CANopen	EtherCAT
1	CAN_H	ECAT_OUT_Tx+
2	CAN_GND	ECAT_OUT_Rx+
3	CAN_L	ECAT_OUT_Rx-
4	CAN_GND	ECAT_OUT_Tx-

6.7 Communication Cabling

Note

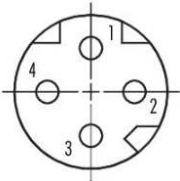
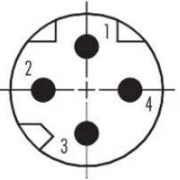
For commissioning and tuning the TIM, the PC running Motion Suite must be connected to the TIM through a serial RS232 port or a USB port with a USB-to-RS232 adaptor.

Once the drive is configured, you can then connect it to a PLC or controller over a CANopen/EtherCAT network.

Serial Cabling

A standard serial USB to RS232 adapter, shown in the following figure, is used to connect the TIM to the PC to enable communication with Motion Suite.



Figure 6-8 USB-to-RS232 adapter cable (example)

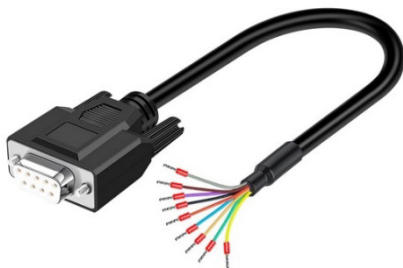

Figure 6-9 RS232/C2 connector cable (example)

Make the following cable connections. Refer to Interface C2 in section 6.5 *Electrical Interfaces*.

1. Before connecting the USB-to-RS232 adapter cable to the PC, be sure the proper device driver is installed in the PC.
1. Connect the USB-to-RS232 adapter cable to the USB port on the PC. The Found New Hardware Wizard will detect the device, and complete the driver installation.
2. Connect the D9 male connector on the USB-to-RS232 adapter cable to the D9 female connector on the RS232/C2 cable.
3. Connect the M8 connector on the RS232 cable to interface C2 on the TIM. Make sure pins 2, 3 and 8 are mated.

CANopen/EtherCAT Cabling

For fieldbus communication, use a cable with an M8 connector to connect to the TIM, and an RJ45 connector to connect to the master controller.



Figure 6-10 CANopen/EtherCAT connector cable (example)

CANopen Chain

If chaining TIM drives in a CANopen network, they can be connector in any order, with cables plugged in to either C4 or C3.

CANopen Termination

In a CANopen network, a 120Ω termination resistor is required on the last node in the chain.

To implement the termination of the CAN bus on the TIM, connect a D-coded, M8 male termination resistor plug, to connector C4/C3 on the last TIM in the chain.

EtherCAT Chain

If chaining TIM drives in an EtherCAT network, they must be connected sequentially; that is, master controller to Drive 1 In/C4 > Drive 1 Out/C3 to Drive 2/C4 In > Drive 2 Out/C3, and so forth.

6.8 Computer System

The Motion Suite software requires Windows 10, 64-bit or higher.

The PC requires either of the following interfaces for serial communication with the TIM.

- A serial RS232 port
- A USB port with an USB-to-RS232 adaptor with ferrite bead.

To view recorded data, you need Microsoft Office Excel, or a similar spreadsheet software that supports CSV files.

6.9 Fieldbus Devices (CANopen/EtherCAT)

- If using CAN protocol, an EDS (electronic data sheet) file for TIM must be loaded on the PC or PLC controller. Download the file from the STXI Motion website, or contact Technical Support.
- If using EtherCAT protocol, an ESI (EtherCAT slave information)/XML file for TIM must be loaded on the PC or PLC controller. Download the file from the STXI Motion website, or contact Technical Support.

6.10 Motion Suite Software

1. Download the Motion Suite installation file from the STXI Motion website or contact Technical Support.
2. Install the Motion Suite on your PC.
3. When installation is complete, you can start Motion Suite from the Windows Start menu or the shortcut on your desktop.

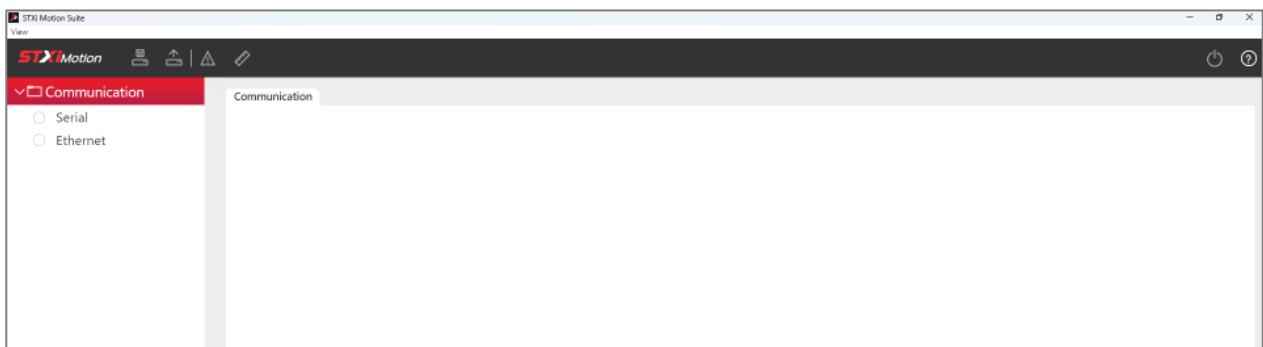

Figure 6-11 Motion Suite – not connected to TIM

Note Motion Suite functionality is not available unless a TIM drive is connected to and communicating with the PC.

6.11 Power Up and Establish Communication

1. After completing the hardware connections and software installations, turn on power to the TIM.
2. Open Motion Suite software, if not already activated.
3. In the navigation menu, select **Communication > Serial**.
4. Confirm that TIM is the selected drive. If not, change the **Drive** setting to TIM.
5. Select the PC's **COM** port that is connected to the TIM.
6. Click **Connect** to enable communication with the drive.

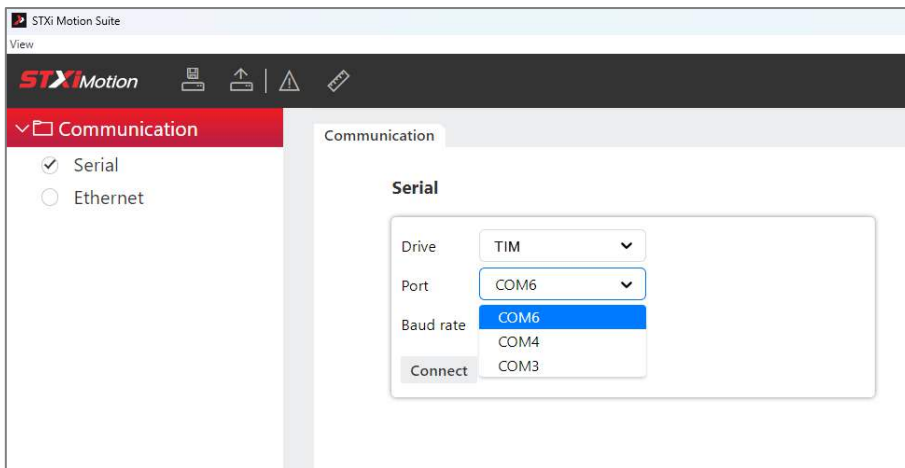

Figure 6-12 Motion Suite – communication settings

Once communication is established, Motion Suite also displays **Drive Info** and **Motor Info**.

For more details, refer to the section *Communication Settings*.

7 Motion Suite Software Overview

Motion Suite is a graphical user interface (GUI) supplied with the TIM servo drive to enable configuration and calibration of the TIM. It also allows you to set certain parameters for the TIM and the particular application in which the drive is used.

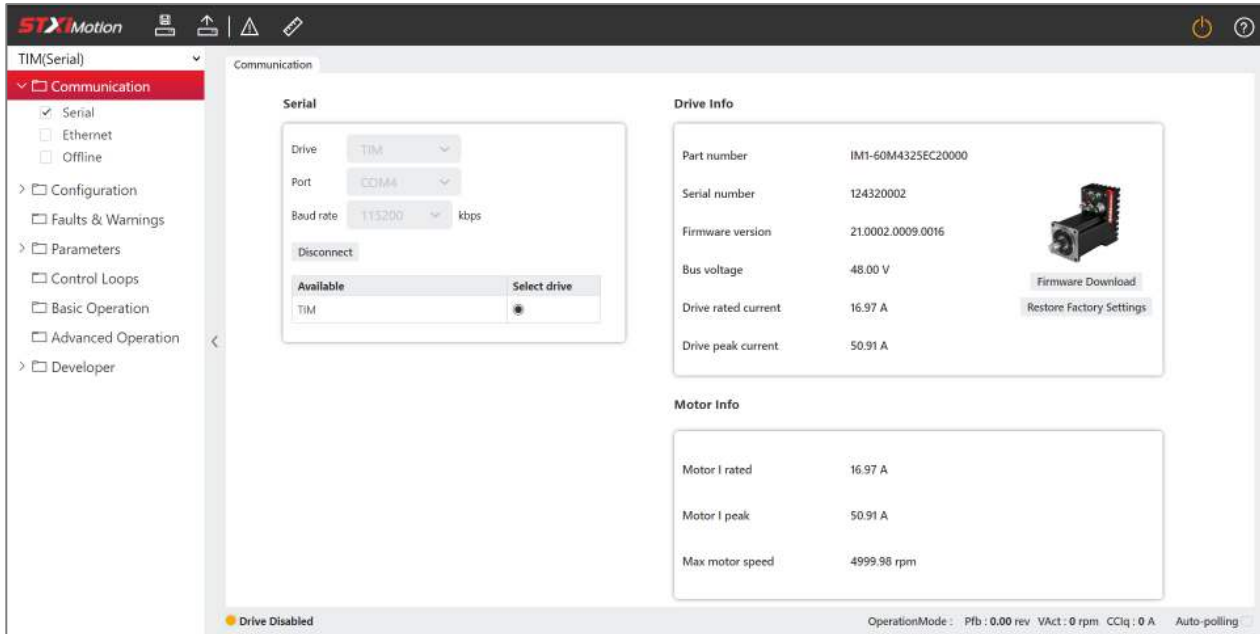

Figure 7-1. Motion Suite Software





7.1 Screen Elements

The Motion Suite software window has a navigation sidebar, a toolbar (top), status bar (bottom), and various task screens.

Motion Suite Toolbar

The toolbar at the top of the screen contains quick access buttons for frequently used functions.

	Help	Opens a help window, which contains a complete list and descriptions of drive parameters.
	Enabled Disabled	Enables and disables the TIM, and indicates the state of the TIM. Green – drive is enabled (active). Orange – drive is disabled (inactive).

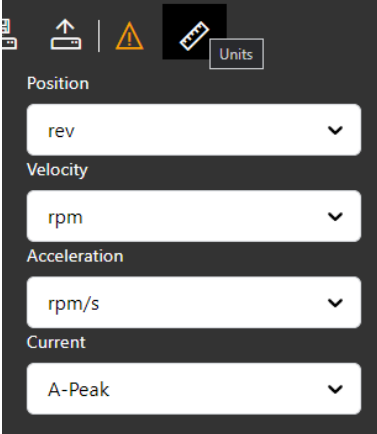
	<p>Save to drive</p>	<p>Saves the parameter values currently in the drive to the drive’s non-volatile (flash) memory. These values are retained in drive memory and reloaded after a power cycle.</p>
	<p>Load from drive</p>	<p>Reads the parameters values saved in drive memory and sets these values in Motion Suite.</p>
	<p>Faults and warnings</p>	<p>Indicates whether any warnings or faults exist in the TIM.</p> <p>White – no warnings or faults. Orange – warnings exist. Red – faults exist.</p> <p>Opens a small message pane that displays the faults and warnings in effect, and includes an option to clear faults.</p> <p>Refer to the chapter <i>Warnings and Faults</i>.</p>
	<p>Units</p>	<p>Opens a menu that allows you to select the unit definitions for position, velocity, acceleration/ deceleration, and current.</p> <p>Default settings: revs, rpm, rpm/second, A-peak.</p> 

Navigation Pane

The navigation pane provides access to the various screens in Motion Suite.

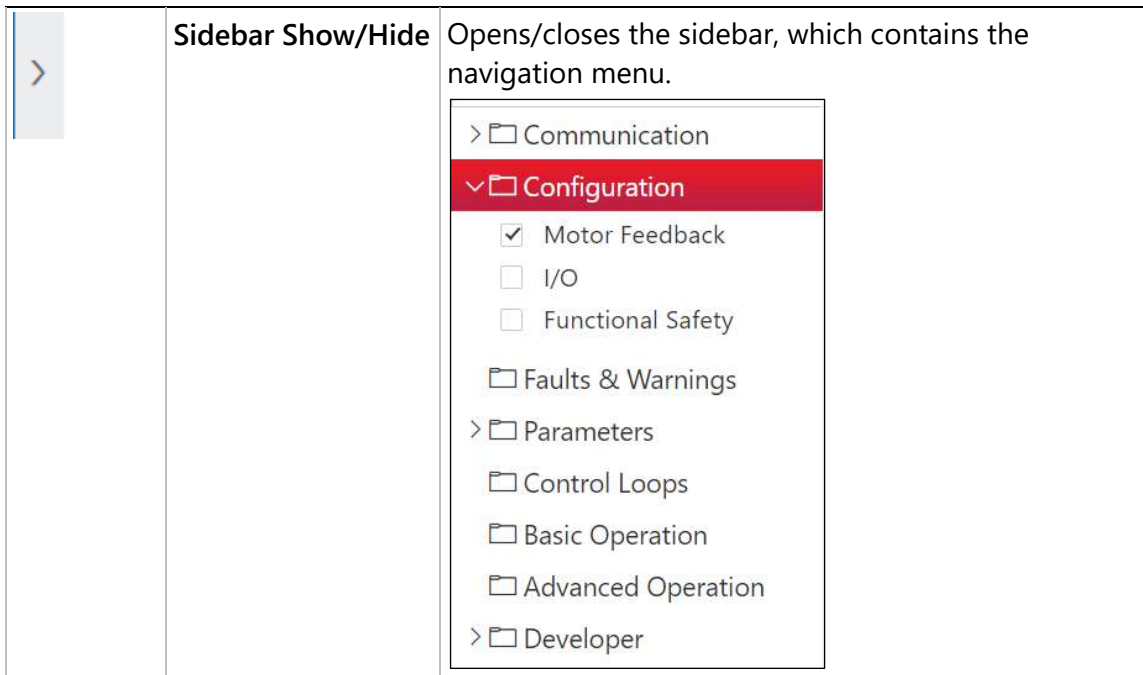

Task Screens

Motion Suite has various interactive screens for viewing, setting and testing parameters and configurations.

Status Bar

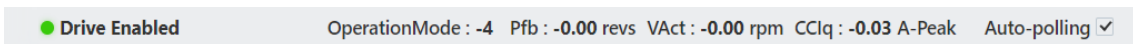

The status bar at the bottom of the screen displays the status of the drive.

Drive status	Notifications from the drive that do not require immediate attention. Currently used to indicate Drive Enabled Disabled status.
Operation Mode	Indicates the currently defined operation mode.
Parameters	Displays the values of motor parameters: CClq Motor torque current Pfb Motor actual position VAct Motor actual velocity
Auto-polling	The values of the parameters in the status bar are automatically updated.

7.2 Communication Settings

The Motion Suite **Communication** screen is used to establish communication between the PC and the TIM.

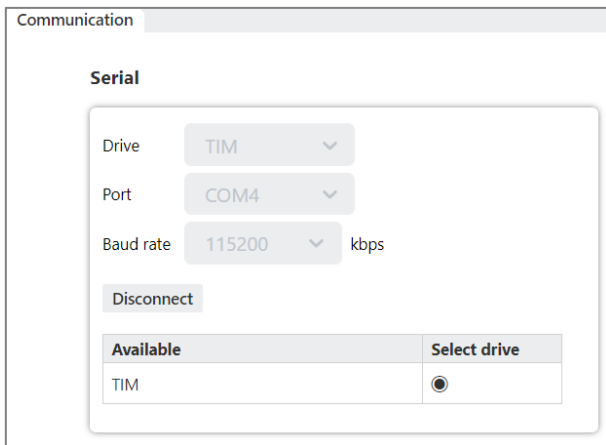

Figure 7-2 Communication settings

For commissioning and tuning the TIM, the PC running Motion Suite must be connected to the TIM through a serial RS232 port or a USB port with a USB-to-RS232 adaptor. Once the drive is configured, you can then connect it to a PLC or controller over a CANopen/EtherCAT network.

Multiple TIM units can be accessed through the same instance of Motion Suite provided they are connected to different COM ports.

Drive	The detected drive on the selected port.
Port	The COM port on the PC to which the TIM is connected.
Baud Rate	By default, the baud rate is 115200. If the setting is changed and saved in the drive’s non-volatile memory, the drive will use the saved baud rate at power up.
Connect / Disconnect	Connect. The software attempts to connect to a device on the selected port. Disconnect. Disconnects the selected device.
Available	Displays the name of the drive detected on the port.

7.3 Basic Operation – Motion Suite Dashboard

The Basic Operation screen is a dashboard that enables you to monitor drive activity and to do quick testing of drive parameters and motion commands.

The screen has a graph that can continuously display plots of drive parameters, but it does not create recordings.

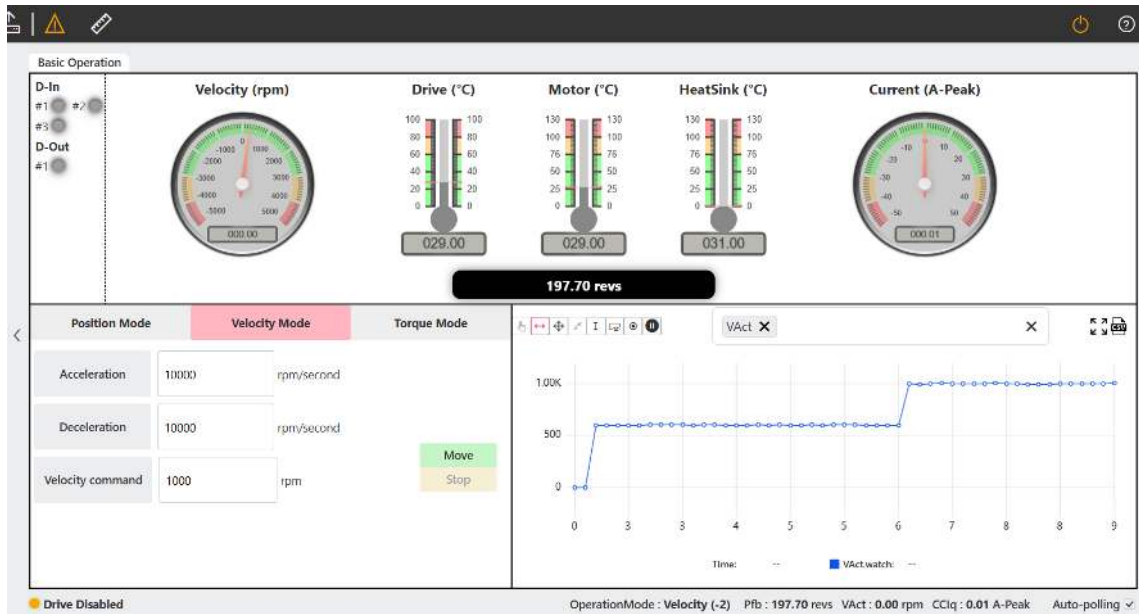

Figure 7-3 Motion Suite – Basic Operation

Status Monitor

The panel of gauges at the top of the screen enables you to monitor the temperature of drive components, motor activity, and the state of digital inputs and outputs.

Velocity	Indicates the velocity value. Defined as rps, rms or degrees/second, according to the Velocity units setting in effect; as defined in the Units menu (in toolbar).
Current	Indicates the current value. Defined as A-peak or A-rms, according to the Current units settings in effect; as defined in the Units menu (in toolbar).
Position	Indicates the position of the motor shaft. Defined in revolutions, degrees or feedback counts, according to the Position units settings in effect; as defined in the Units menu (in toolbar).
Drive	Temperature of the drive CPU (fault threshold: 115°C).
Motor	Temperature of the motor (fault threshold: 120°C).
Heat Sink	Temperature of the heat sink (fault threshold: 90°C).
Digital Inputs/Outputs	Reflects the state of the digital inputs and output. If I/O polarity is inverted, the display will update accordingly.

Movement Modes and Command Execution

The panel at the lower left of the screen enables you to switch movement modes and execute motion commands.

To switch modes, the drive must be disabled.

Position Mode	
Acceleration	The acceleration value of the movement command.
Deceleration	The deceleration value of the movement command.
Velocity	The velocity of the movement command.
Position Command	The target position of the movement command.
Velocity Mode	
Acceleration	Acceleration value.
Deceleration	Deceleration value.
Velocity Command	The velocity of the movement command.
Torque Mode	
Current Command	The torque (current) value of the movement command.

After the movement command parameters are defined, use the following options.











Move	If the command is valid, the movement command will be executed. After the movement command is executed, plots of the selected parameters will appear on the graph.
Update	After Move is pressed, the button switches to Update . Update sends a new command value to the drive. The drive executes the updated movement command and plots new parameter values. In Position mode. A value can be updated only after the command currently being executed has finished. In Torque and Velocity modes. A value can be updated even if the drive is currently executing another movement command. As soon as Update is pressed, the movement will change accordingly,
Stop	Stops execution of the movement command, but does not disable the TIM. While stopped in this manner, only the velocity and current command values can be modified. Other values cannot be modified.

Chart

The panel at the lower right of the screen continuously plots the values of selected parameters.

Use the toolbar at the top to manipulate the behavior and display of the chart.



	Pan	Click on the plot and drag to pan.
	Zoom X	Click on the chart and then drag to the right to select a portion of the plot to enlarge. This magnifies the X-axis of the plot.
	Zoom XY	Click on the chart and then drag to select a specific area of the plot to enlarge. This magnifies both the X and Y axes of the plot.
	Reset View	Resets the chart display to the default zoom setting.
	Cursors	Click on the chart to insert a cursor line. Click again on the chart to insert a second cursor line. Click and drag the cursor lines to position precisely on the chart. NOTE: The first, blue cursor line must be on the left. The second, red cursor line must be on the right. Otherwise, data will not be calculated.
	Overview	Displays the entire length of the recording. Useful when zooming in to a specific segment of the plot.
	Live Watch	When selected, Motion Suite continuously reads and plots parameter values from the drive, even without execution of any motion commands. Motion Suite reads and plots changing parameter values caused by manual movement of the motor. To stop the continuous display, toggle the button.
	Pause	Pauses the plotting. To resume plotting, toggle the Pause button.
	<i>select parameters</i>	Click in the field and begin typing a parameter. A list of available drive parameters is displayed based on the characters typed. Up to 3 parameters can be selected when the chart pane is in the small form. Up to 5 parameters can be selected when the chart panel is expanded to full screen.
	Full screen	The recorder chart expands to fill the entire software screen.
	CSV File	Exports the data in the last recording to a CSV file.

7.4 Parameters

The Parameters screen allows you to monitor and modify the values of the drive parameters. The parameter list includes both serial parameters and EtherCAT objects.



Disable the TIM before manipulating motor and feedback parameters.

Many parameters can be modified while the TIM is enabled.

Exercise caution, however, as motor behavior will change.

If a parameter cannot be modified while the TIM is enabled, Motion Suite will prompt you to disable the TIM.

You can display a partial list of parameters by selecting one or more categories in the navigation menu.

Click the **Save** button  on the toolbar to save all parameters to the drive's non-volatile memory.

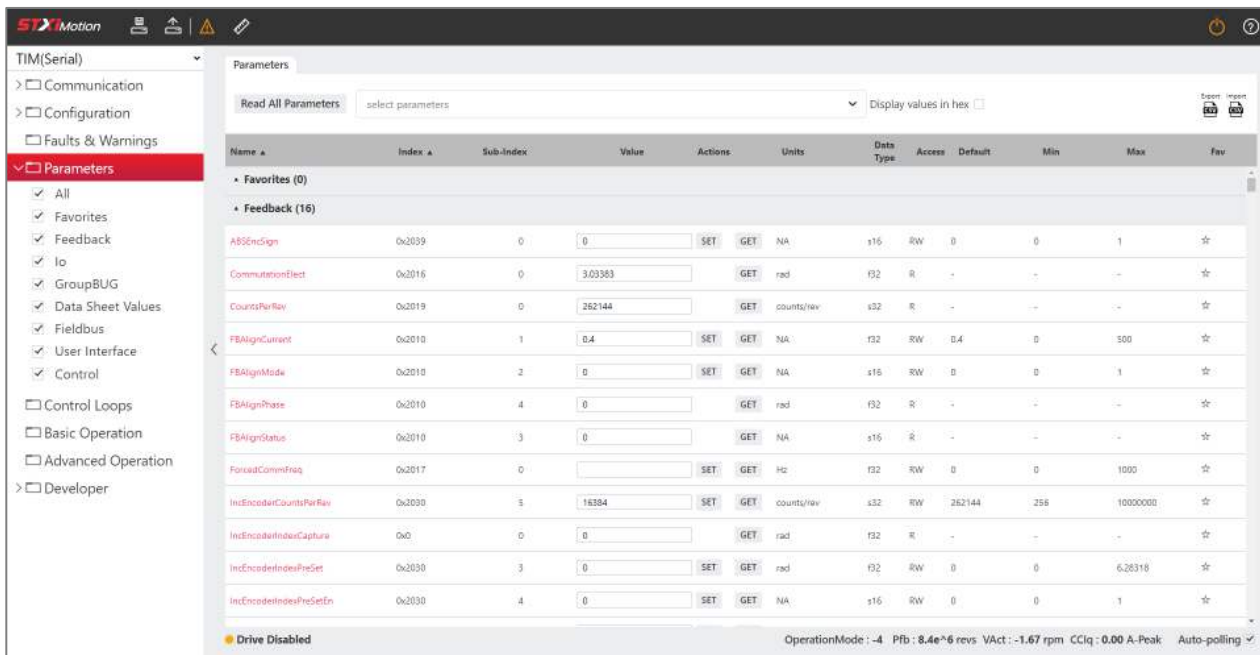



Figure 7-4. Motion Suite – Parameters screen

	Read All Parameters	Reads and displays the values of all parameters in the drive.
	<i>Select(ed) parameters</i>	User-selected parameters for monitoring and/or manipulation.
	Display values in hex	Toggles the display of parameter values between hexadecimal and decimal format.

	Export Parameters	Saves all the parameters in the drive to a CSV file, and automatically downloads the file to the Download folder on your PC. You can rename the file and store it in any other location on your PC.
	Import Parameters	Browse to and select the CSV parameter file you saved on your PC.

The Parameters table displays the following data:

Name	The parameter’s abbreviation, as used in Motion Suite. To view the parameter definition and description, click this name. The hyperlink opens the help window for the specific parameter.
Index	The CANopen/EtherCAT object index for parameters, where applicable. Note: Parameters that display 0x0 are for use in serial only, and are not available in CANopen/EtherCAT.
Sub-Index	The CANopen/EtherCAT object sub-index for parameters, where applicable.
Value	<p>Note: Read-only parameters do not have the Set Value option.</p> <p>After entering or modifying a parameter value, press Enter or the Set Value button to send the value to the drive.</p> <ul style="list-style-type: none"> ▪ If the value entered is valid, a dotted green frame is displayed momentarily around the field. The new value is then displayed. ▪ If the value entered is invalid, a dotted red frame is displayed momentarily. An error message shows the range of valid values, and prompts you to correct your entry. <p>To save the value in the drive’s non-volatile memory, use the Save button on the toolbar. Otherwise, any modified parameter values will be lost during power cycle.</p> <p>Note: If you have changed the value of a parameters in another Motion Suite screen, the updated value will be automatically displayed when you switch to the Parameters screen.</p>
Actions	<p>SET: Sends the value to the drive. (Note: This option is not available if a parameters is read-only.)</p> <p>GET: Reads the parameter value in the drive.</p>
Units Data Type Access Default Min/Max	Read-only parameter data.

Favorites <i>(star)</i>	Displays a list of parameters that you want to monitor. When marked as a favorite, the parameter remains displayed at the top of the parameters table.
-----------------------------------	---

For more details about a specific parameter, do either of the following:

- Hover over the parameter name to view the parameter definition and description, and its minimum and maximum values.
- Click on the parameter name. This opens the Motion Suite Help file, and displays the parameter data.

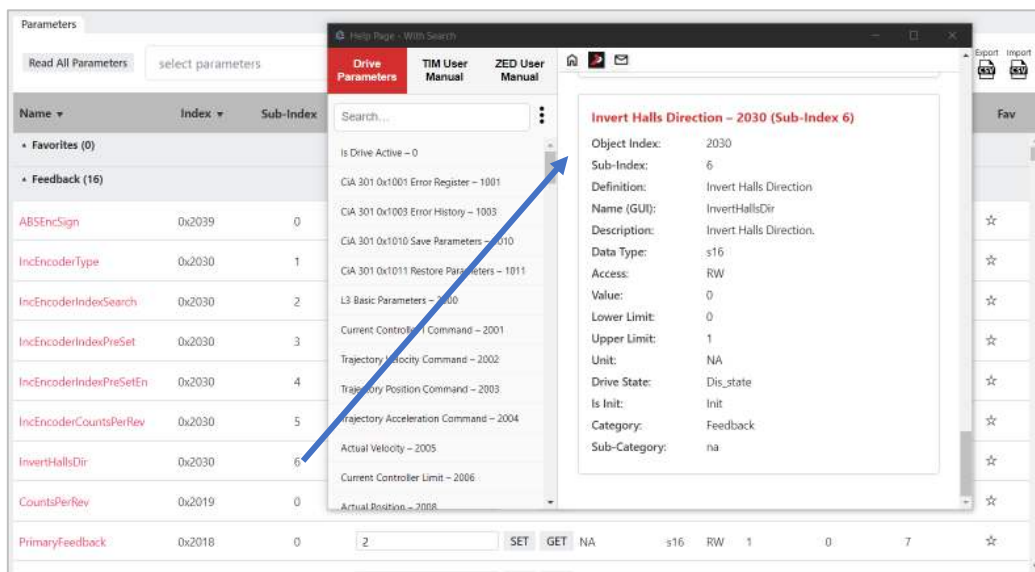

Figure 7-5. Motion Suite – Parameters Help

8 TIM Motor Setup

Confirm TIM Settings and System Units

After completing the hardware connections and software installations, turn on power to the TIM.

Open Motion Suite software, if it is not already activated.

1. Note the product information that is displayed in the Communication > **Serial** screen.
2. The **Drive Info** pane displays an image of the TIM drive.
Refer to the product labels on the TIM to confirm that the displayed data is correct.
3. The **Motor Info** pane reads and displays a preset motor definition from the drive.

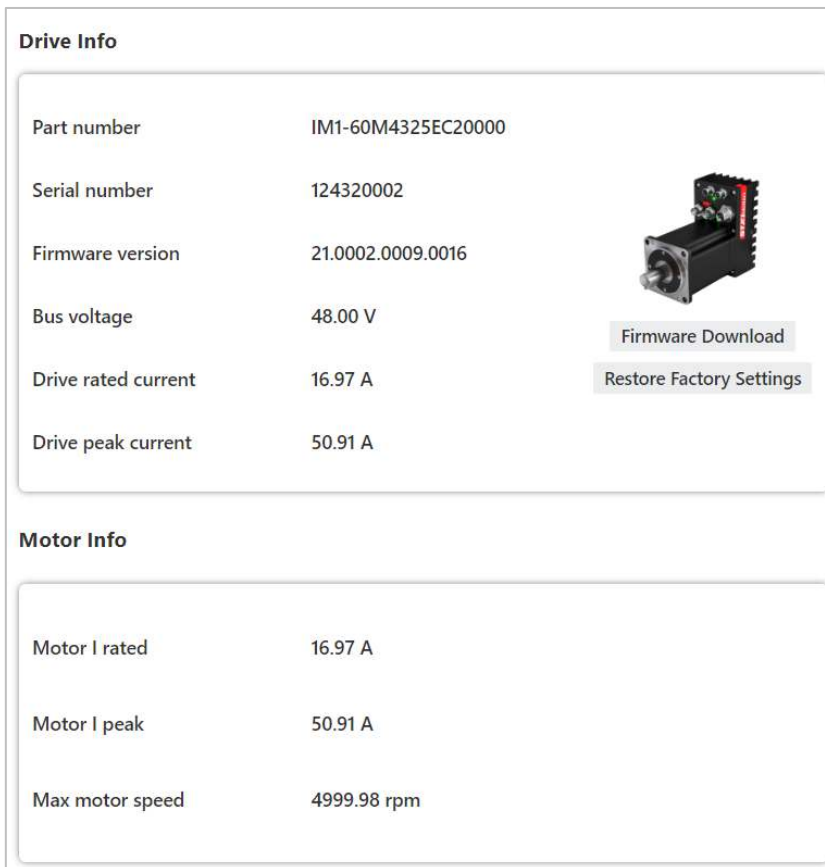

The screenshot displays two panes in the Motion Suite software. The top pane, titled "Drive Info", contains a table of drive parameters and a small image of the TIM drive. The bottom pane, titled "Motor Info", contains a table of motor parameters. To the right of the Drive Info table are two buttons: "Firmware Download" and "Restore Factory Settings".

Drive Info	
Part number	IM1-60M4325EC20000
Serial number	124320002
Firmware version	21.0002.0009.0016
Bus voltage	48.00 V
Drive rated current	16.97 A
Drive peak current	50.91 A



Firmware Download
Restore Factory Settings

Motor Info	
Motor I rated	16.97 A
Motor I peak	50.91 A
Max motor speed	4999.98 rpm

Figure 8-1. Motion Suite – Drive and Motor info

- To view motor data, select **Configuration** from the navigation menu.

The **Motor** screen is displayed.

Note

Once you have connected to a TIM motor, you cannot make any changes to its predefined parameters values. The values displayed in this screen are read-only.

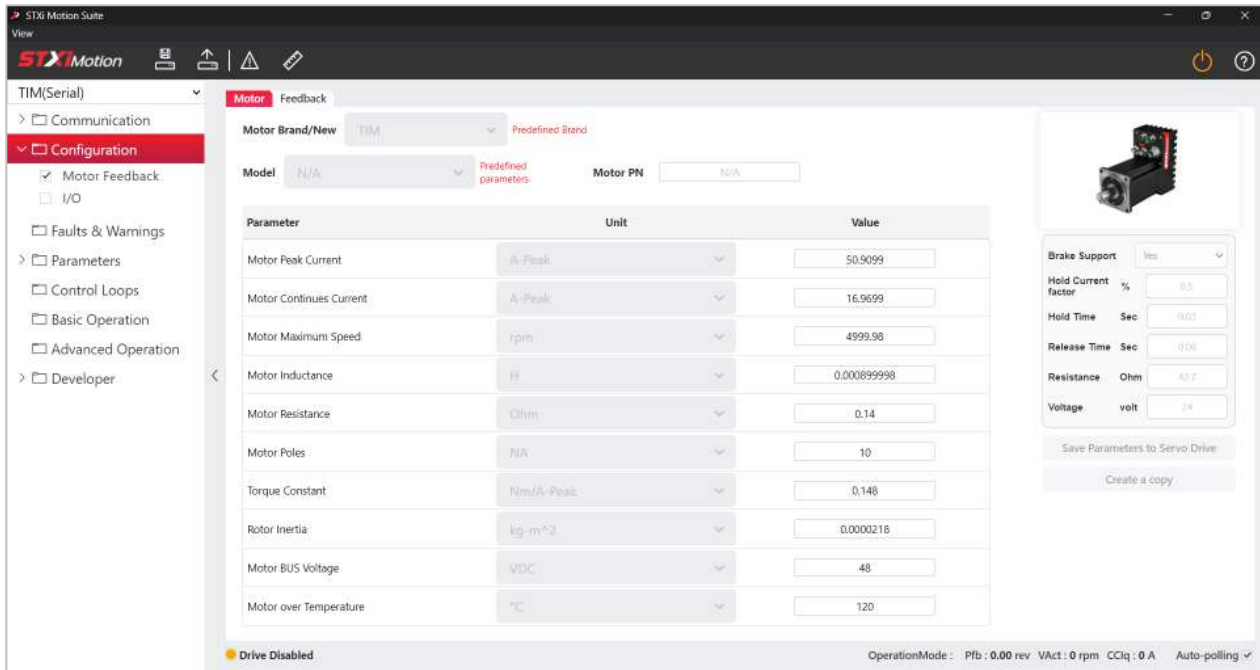

Figure 8-2. Motor screen

- In the toolbar, select the **Units** (ruler) button. The **Units** menu opens.

Confirm that **units** are correctly set for your application. If necessary, you can modify these settings.

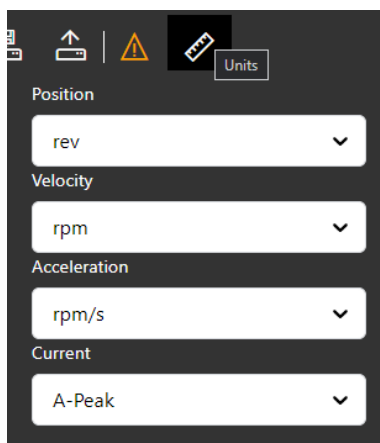

Figure 8-3. Motion Suite – units

Test the Motor Response to a Torque Command

Note Test the motor **without a load** to confirm the motor moves in response to a torque command. After confirming proper motion, you can then add the load and/or install in your application.

To test the motor response, do the following.

1. Open the **Basic Operation** screen.
2. Select the Torque mode tab.
3. In the Current command field, enter **1** (A-Peak).
4. Press **Move** (or **Update**).

Check the velocity gauge in the software. You should see a positive value.

Check the motor. You should see it move in the positive (counter-clockwise) direction. To more easily view the actual motor motion, reduce the A-Peak value.

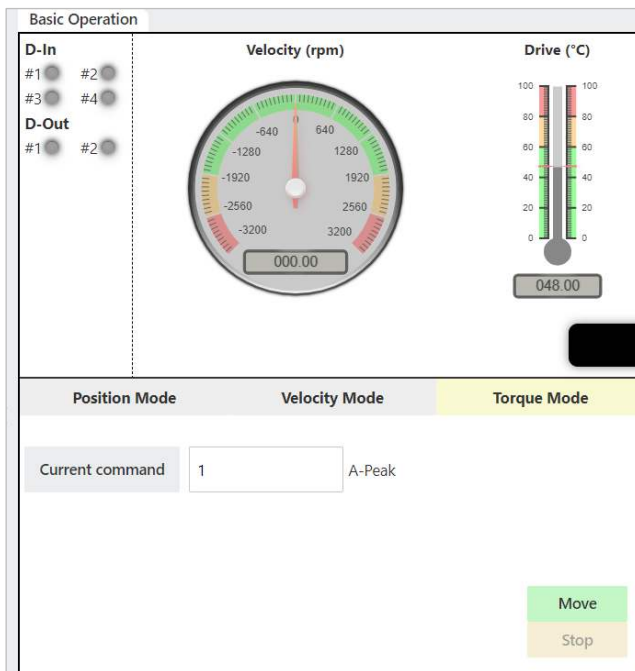

Figure 8-4. Motion Suite – torque positive motion

5. Press **Stop** to stop the motor motion.
6. In the Current command field, enter **-1** (A-Peak).
7. Press **Move** (or **Update**).

Check the velocity gauge in the software. You should see a negative value.

Check the motor. You should see it move in the negative (clockwise) direction. To more easily view the actual motor motion, reduce the A-Peak value.

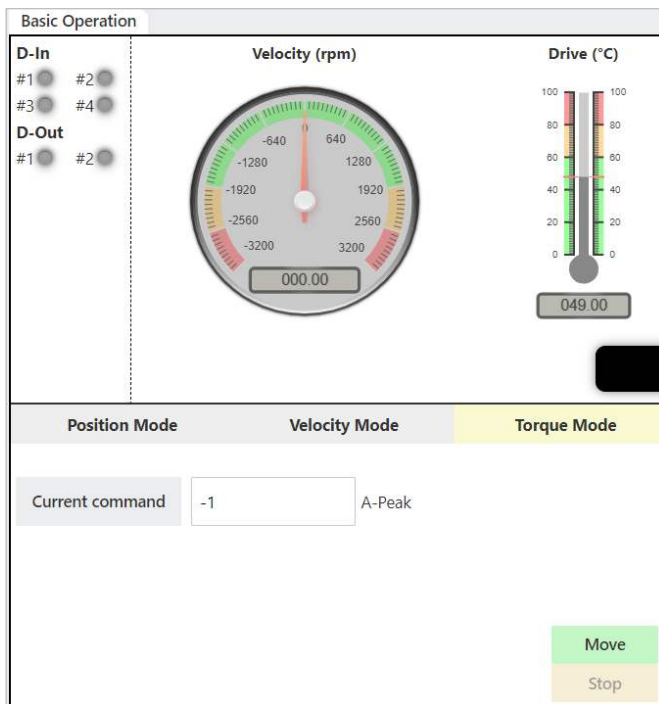

Figure 8-5. Motion Suite – torque negative motion

8. Press **Pause** to stop the motor motion.

If the motor moves as expected, you can now install the TIM in your application system or install the load on the shaft of the motor. Then proceed to tune the drive.

If there is a problem, contact STXI Motion Technical Support.

9 Tuning the Control Loop

Note To better understand the use of recording functions, parameters and other Motion Suite features mentioned in this chapter, refer to the descriptions in the chapter *Advanced Operation*.

Turn Off All Velocity Filters

Note There is no need for filters during the drive commissioning procedure.

Note Do not attempt to manipulate filter parameters unless specifically instructed to do so by STXI Motion Technical Support.

1. Open the **Control Loops** screen.

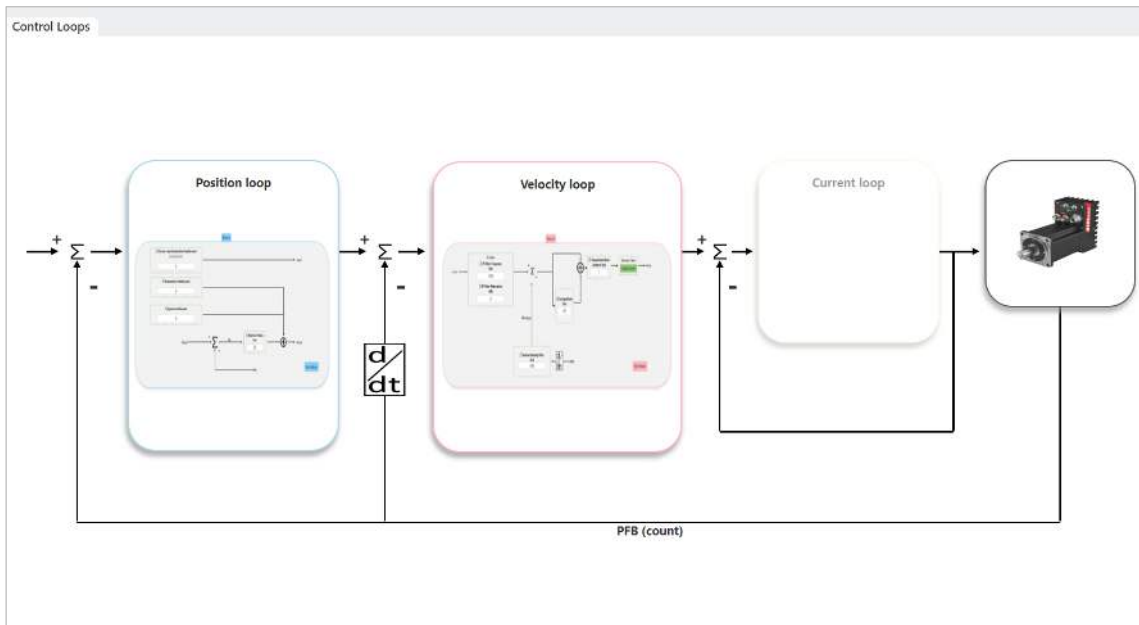

Figure 9-1. Motion Suite – Control Loops screen

2. Click on the Velocity Loop segment to enlarge the schematic dialog box.
3. Clear the option **Hide Filters**.

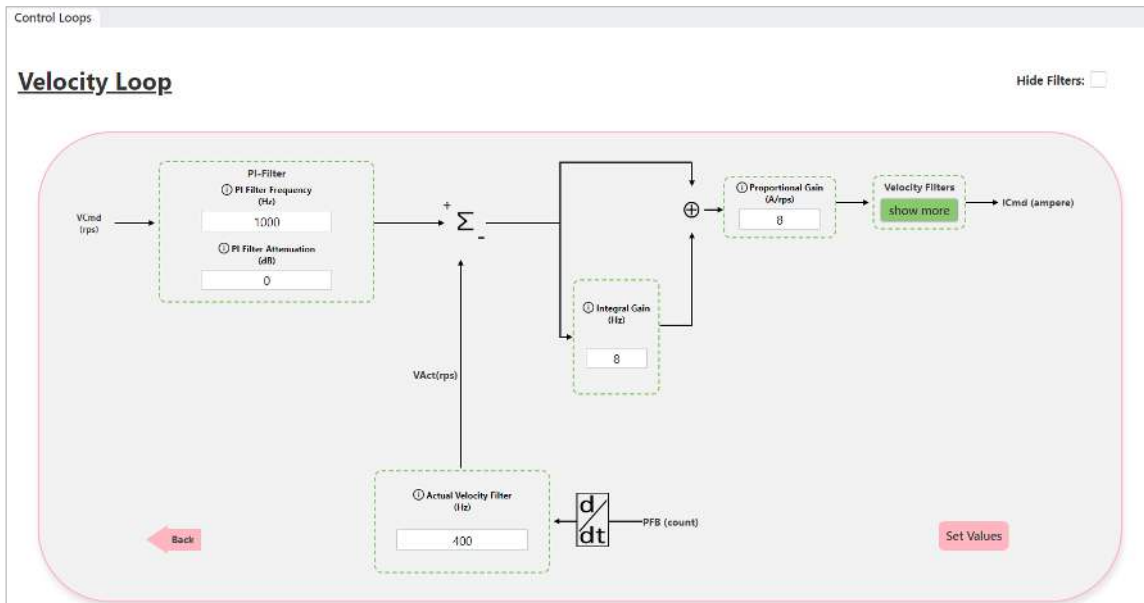

Figure 9-2. Motion Suite – Velocity Loop schematic dialog

4. In the Velocity Filters segment, press **Show More**.
5. In the Velocity Filters dialog box, select **0-None** for both Filter 1 and Filter 2 Type. This turns off all velocity filters.

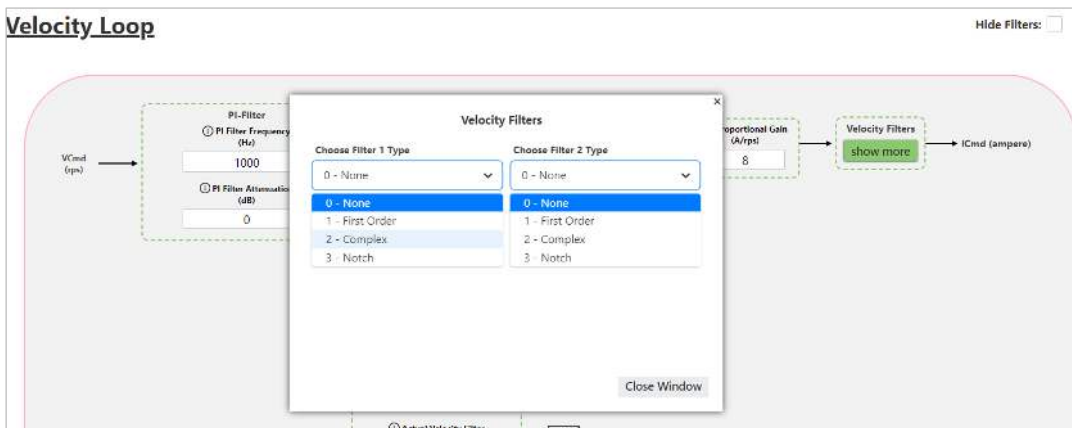

Figure 9-3. Motion Suite – Velocity Filters

Tune the Gains in Velocity Loop

Note

The TIM system has three levels of control, which enable the user to decide whether to use minimal parameter modification, or a more complex control design. Parameter settings from Level 1 can be incorporated into Level 2, which can then be integrated into Level 3 control.

Levels 1 and 2 rely on the TIM Autotuning feature, which is still in development. Therefore, the instructions for tuning the drive use Control Level 3 (L3) parameters.

To set the velocity integral gain (L3ki) and velocity proportional gain (L3kv), do the following.

1. Open the **Advanced Operation** screen.
2. Select the Velocity Mode tab.
3. Set Acceleration, Deceleration, and Velocity command values appropriate for your application. The values shown in the figure below should be suitable.
4. In the Tuning Parameters pane, set **L3ki** (velocity integral gain) to **0**, and set **L3kv** (velocity proportional gain) to **0.001**. Press **Set parameters**.

Note Be sure to press **Set parameters** after modifying values in the Tuning Parameters pane. Otherwise, values will not be updated in the drive.

5. In the Recording Setup pane, do the following:
 - a. Define a recording time that will be sufficient to capture the entire acceleration phase until the motor reaches a constant velocity. For example, set Gap to **16**, and Points to **2000**. Total time will automatically be set to 2 seconds.
 - b. Select the parameters **Vact** and **Vcmd** to be recorded.
 - c. Set the Trigger Condition to **Immediate**.
 - d. Enable the option **Delete Previous Records**.

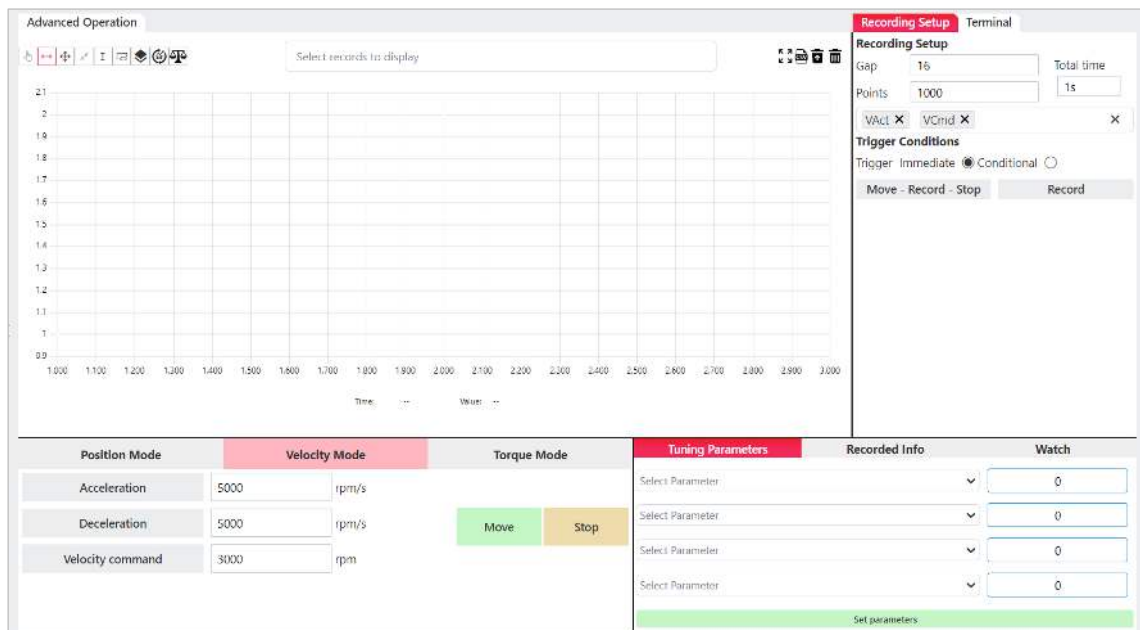

Figure 9-4. Motion Suite – Advanced Operation screen for recording

Note This figure shows the current software interface. Due to software updates, the screens shown in other figures in this chapter may differ from what you see in your software interface. The instructions in this chapter are accurate.

6. Press **Move**.

Note that the motor should **not** move.

7. Wait for the velocity command to be executed, and for the recording plot to be displayed on the graph.

You should see a half-trapezoid, representing the acceleration and target speed of the velocity command.

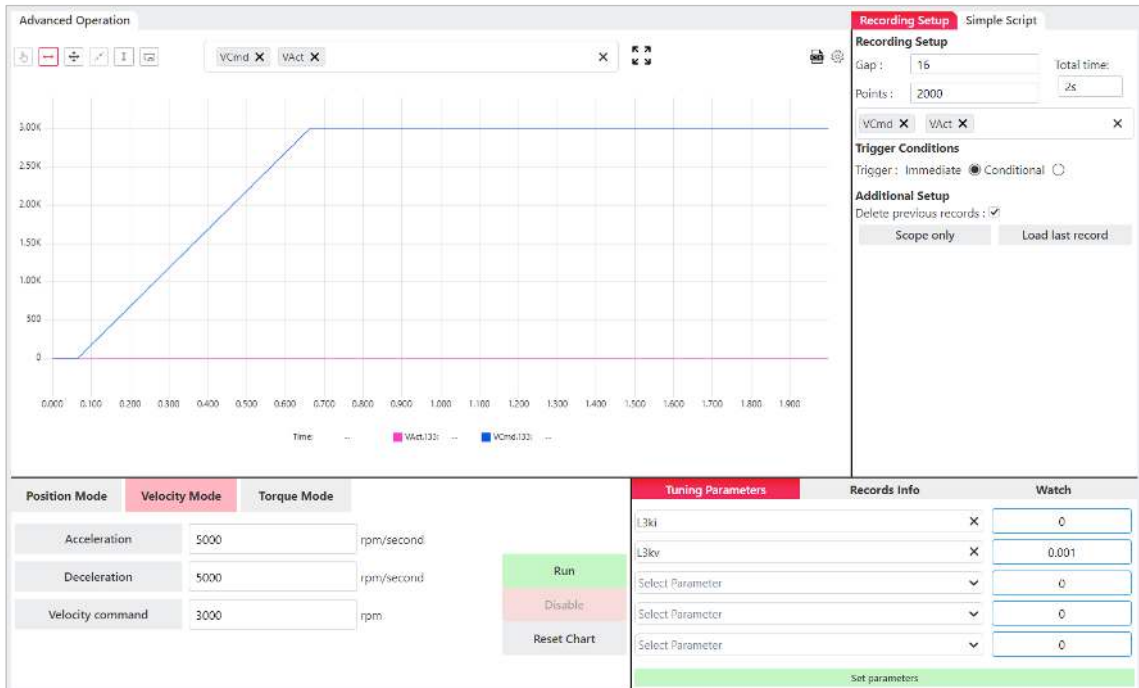

Figure 9-5. Velocity command profile

8. Leave the value of L3ki (velocity integral gain) at 0, and do the following:
 - a. Gradually increase the value of L3kv (velocity proportional gain), in increments ranging between 0.5 to 1.0.
 - b. Press **Set parameters**.
 - c. Press **Move/Update** (*previously, Run*).
 - d. Check the recorded plot.
 - e. Repeat steps a to d until you see that the actual velocity value closely follows the velocity command value.

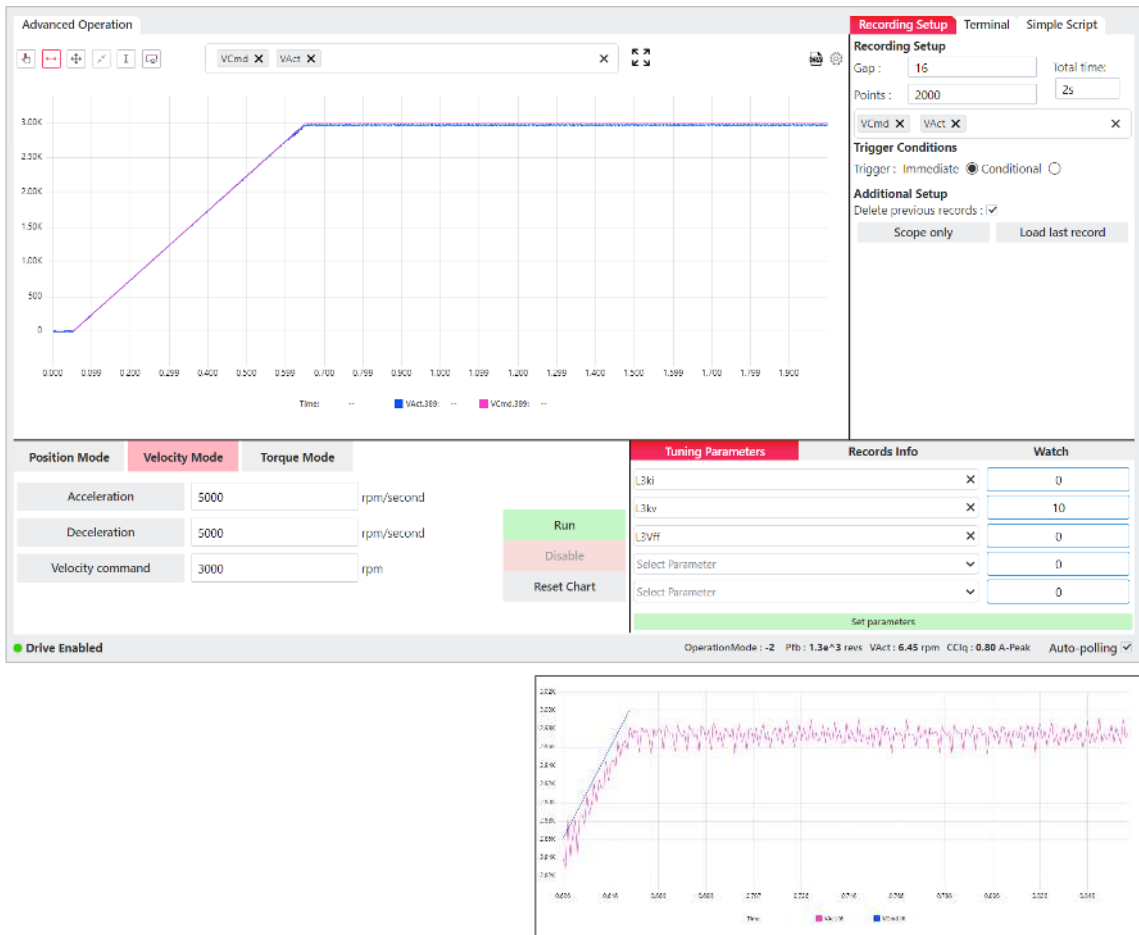

Figure 9-6. Velocity gains – preliminary tuning (inset: before tuning L3ki)

9. With the drive **enabled**, gradually increase the value of L3ki (velocity integral gain), in increments of 10, until you hear the motor making distinct crackling sounds. Be sure to press **Set parameters** each time you modify L3ki.
10. Once you reach this noisy motor condition, reduce the value of K3kv by half, and press **Set parameters**.
11. Press **Move/Update** (*previously, Run*).

In the recorded plot, you should see that the actual velocity value overlaps the velocity command value.

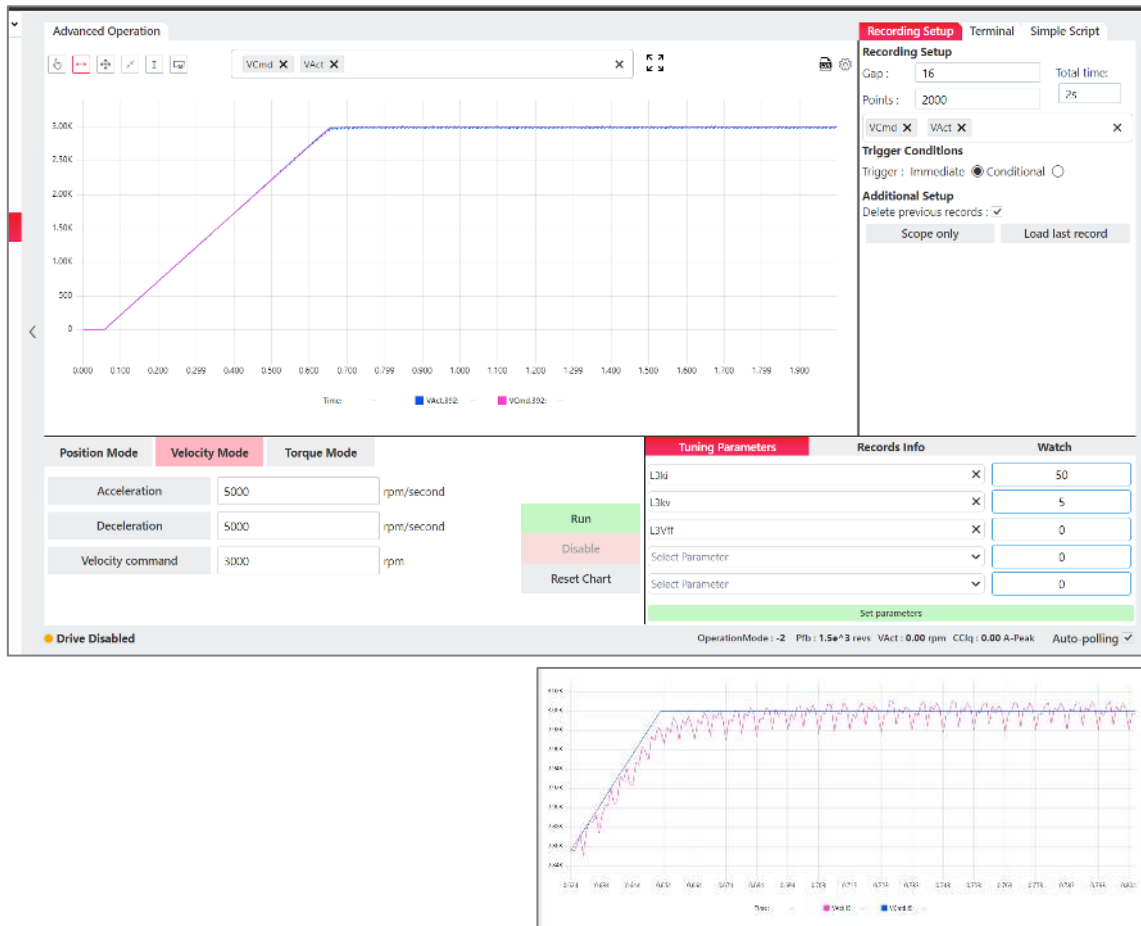

Figure 9-7 Velocity gains optimization (inset: after tuning L3ki)

12. If necessary, continue to adjust the parameters, without causing any distinct motor noise, or with as little noise as possible:
 - Increase the velocity integral gain (L3ki) in increments ranging between 1 and 2.
 - Increase the velocity proportional gain (L3kv) in increments ranging between 0.05 and 0.1.

Test the Position Loop

After setting the velocity gains, make sure the position profile is also a trapezoid.

To test the position control loop, execute a position command that is appropriate for your application. The values shown in the figure below should be suitable.

1. In the Advanced Operation screen, select the **Position Mode** tab.
 - a. Keep the same Acceleration, Deceleration, and Velocity command values that you used in Velocity Mode.
 - b. Set the Position command value.
 - c. Enable the option for **Incremental** position.
2. Press **Move/Update** (previously, Run).

The recorded plot should be a trapezoid that represents the motion profile.

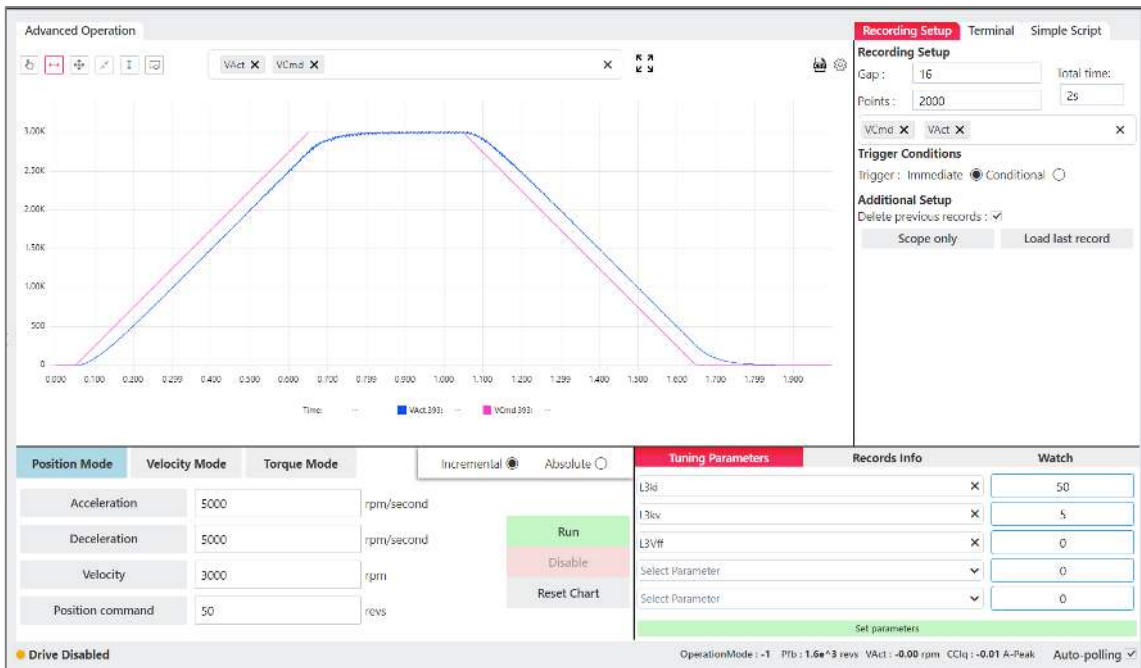

Figure 9-8. Position motion profile

Optimize the Position Error

1. In the Recording Setup pane, delete parameters Vcmd and Vact.
Select the parameter Pe (position error) to be recorded.
2. Press Move/Update (previously, Run).
The recorded plot should be a trapezoid that represents the position error.

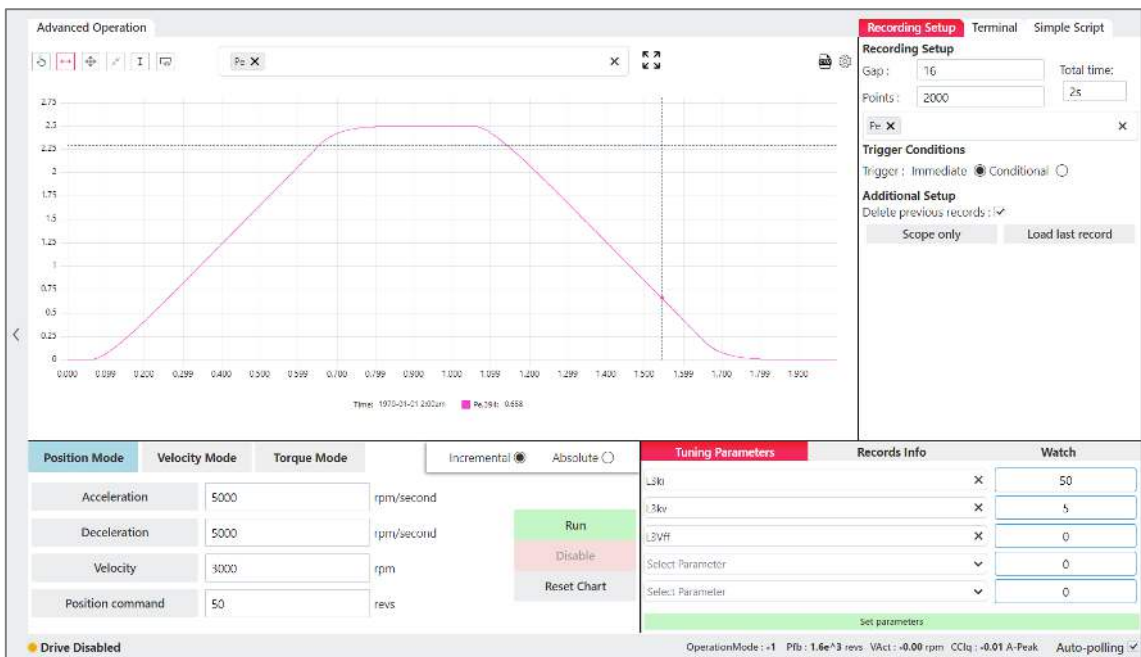

Figure 9-9. Position error profile

3. To reduce the position error and achieve optimal following of the motion profile, add velocity feedforward to the control loop.
 - a. In the Tuning Parameters pane, add the parameter **L3Vff** (Velocity Feedforward).
 - b. Set the value of L3Vff to **1**, and press **Set parameters**.
 - c. Press **Move/Update** (previously, *Run*).

The recorded plot of the position error should resemble the one shown in the following figure.

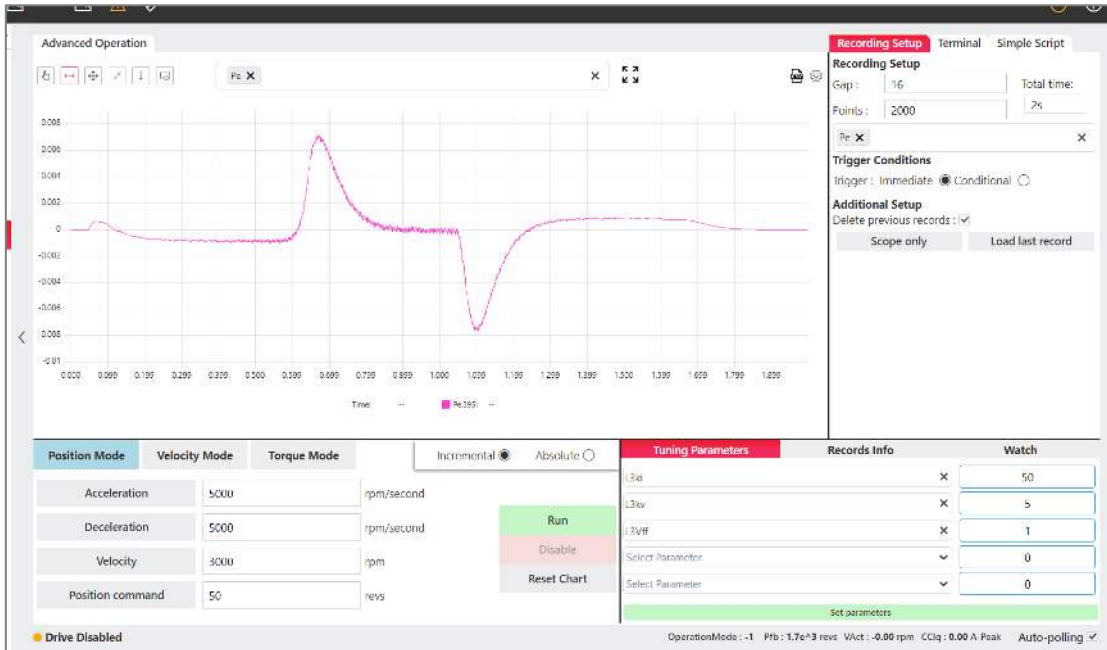

Figure 9-10. Optimization of position error, with velocity feedforward

If the plot displays a velocity ripple, as shown in the following figure, contact STXI Motion Technical Support.

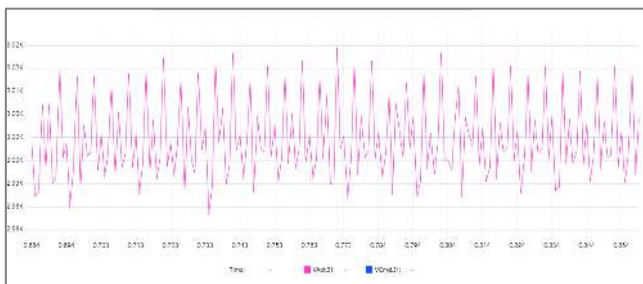

Figure 9-11. Velocity ripple

Save the Control Parameters to the Drive

When satisfied with the results of tuning, press the **Save to drive** button in the toolbar.



10 Advanced Operation

The functions in this screen are primarily intended for use by control engineers, developers, and STXI Motion Technical Support.

The Motion Suite **Advanced Operation** screen provides data recording and plotting capabilities.

Recording is done by the drive in real-time, and sent to Motion Suite for display.

Recording can be set up to be triggered when a specified condition occurs.

The software also allows execution of a motion command during recording. This is useful, and even necessary, as a tuning tool.

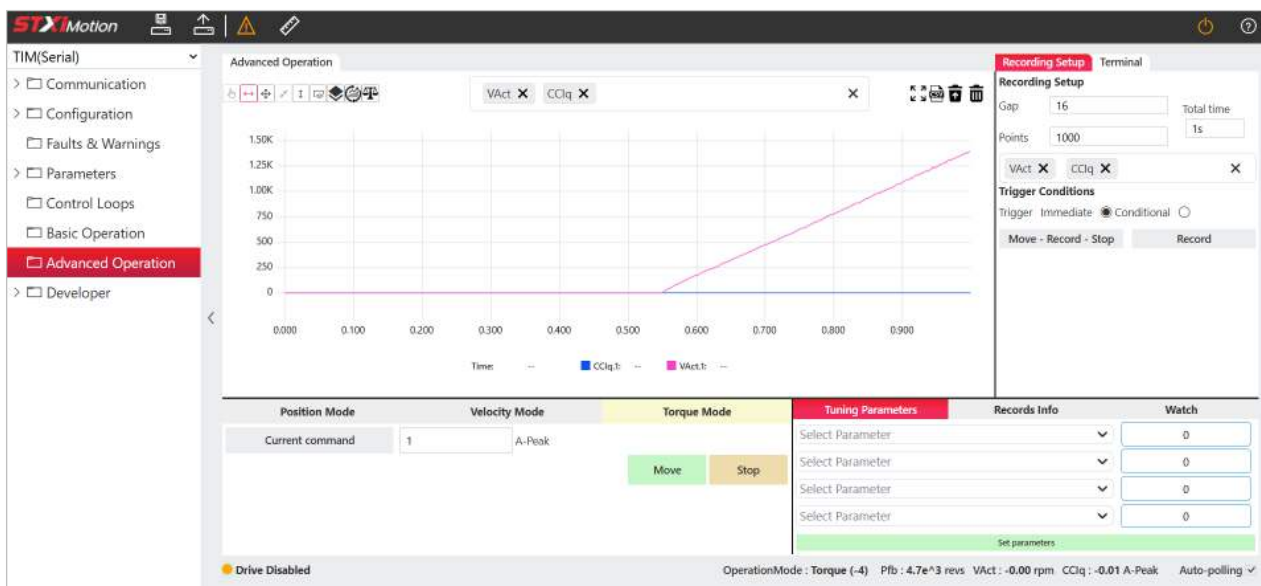

Figure 10-1. Motion Suite – Advanced Operation screen

10.1 Motion Modes and Execution

The panel at the lower left of the screen enables you to switch movement modes and execute motion commands.

To switch modes, the drive must be disabled.

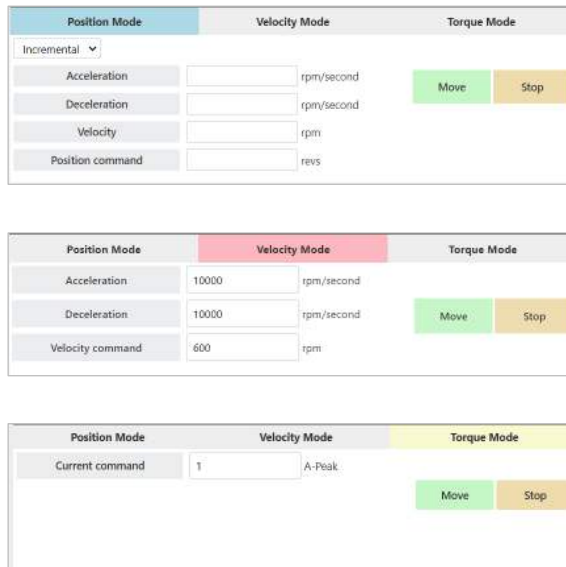

Figure 10-2 Motion Modes and Activation

Position Mode	
Acceleration	The acceleration value of the movement command.
Deceleration	The deceleration value of the movement command.
Velocity	The velocity of the movement command.
Position Command	The target position of the movement command.
Incremental/Absolute (toggle)	<p>Incremental. Moves the motor the specified number of (defined units) from the encoder 0 position. Executes an absolute position movement according to the motion settings.</p> <p>Absolute. Moves the motor the specified number of (defined units) from its current location. Executes an incremental position movement according to the motion settings.</p>
Velocity Mode	
Acceleration	Acceleration value.
Deceleration	Deceleration value.
Velocity Command	The velocity of the movement command.
Torque Mode	
Current Command	The torque (current) value of the movement command.

After the movement command parameters are defined, use the following options.

Move	If the command is valid, the movement command will be executed. After the movement command is executed, plots of the selected parameters will appear on the graph.
Update	After Move is pressed, the button switches to Update . Update sends a new command value to the drive. The drive executes the updated movement command and plots new parameter values. In Position mode. A value can be updated only after the command currently being executed has finished. In Torque and Velocity modes. A value can be updated even if the drive is currently executing another movement command. As soon as Update is pressed, the movement will change accordingly,
Stop	Stops execution of the movement command, but does not disable the TIM. While stopped in this manner, only the velocity and current command values can be modified. Other values cannot be modified.

10.2 Recording Setup and Activation

The **Recording Setup** panel allows you to define the parameters and conditions for the data recording.

Figure 10-3 Recording Setup

Recording Setup

Gap	The rate at which data is recorded. The interval value is specified in multiples of the drive's basic sampling rate, which is 62.5 μ s. For example, a gap of 10 means data is recorded once every 10 samples, that is, every 0.625 seconds. The calculated total recording time is also indicated, in seconds (s).
Points	The total number of points to be recorded.
Parameters (to be recorded)	From the list, select one or more parameters to be recorded. In general, do not attempt to set more than 5 parameters and/or 2000 points. (Actual limits will vary depending on the system). If too many parameters and/or samples are defined, the recording will not begin and an error message will be displayed.

Trigger Conditions

Trigger	Immediate. Recording starts immediately, without any conditions. Conditional. Starts the recording as soon as condition is met.
Parameter	Parameter whose value will trigger the recording.
Condition	Defines whether the trigger occurs when value of the variable goes above the threshold (Up) or below the threshold (Down). <ul style="list-style-type: none"> ▪ Above ▪ Below ▪ Absolute Above (+/-) ▪ Absolute Below (+/-)
Value	The threshold value for the trigger. If parameter has a range, it will show the min and max values. Value : min value : <input type="text"/> max value :
Points Before	The number of points to be recorded prior to the trigger point.



Figure 10-4 Move and Record

The following options can be used in combination to generate motion and one or more recording plots.

Move-Record-Stop	Executes the motion command as defined in Record Setup, records the data as defined in Record Setup, then stops the motor, and plots the recorded data.
Record	Activates the recording defined in Recording Setup.
Move	Executes the defined motion command, and enables multiple Record instructions. (e.g., Move, Record, Record, Record)
Stop	Stops execution of the motion.

10.3 Recording Charts

After a recording command is executed, a plot appears on the chart.

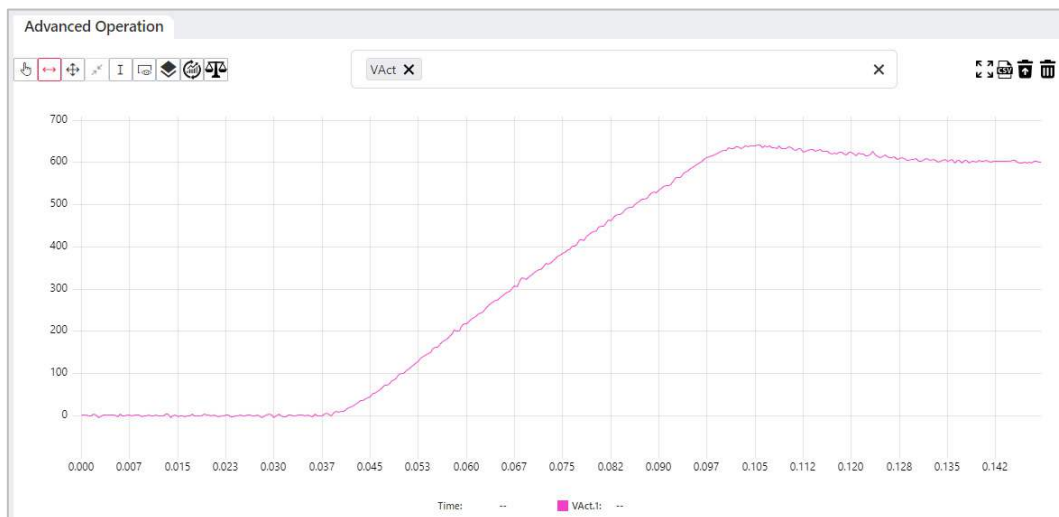











Figure 10-5. Motion Suite – Advanced Operation - Chart

Use the toolbar at the top to manipulate the behavior and display of the recording chart.

	Pan	Click on the plot and drag to pan.
	Zoom X	Click on the chart and then drag to the right to select a portion of the plot to enlarge. This magnifies the X-axis of the plot.
	Zoom XY	Click on the chart and then drag to select a specific area of the plot to enlarge. This magnifies both the X and Y axes of the plot.
	Full screen	The recorder chart fills entire screen.

	Cursors	<p>Click on the chart to insert a cursor line.</p> <p>Click again on the chart to insert a second cursor line.</p> <p>Click and drag the cursor lines to position precisely on the chart.</p> <p>NOTE: The first, blue cursor line must be on the left. The second, red cursor line must be on the right. Otherwise, data will not be calculated.</p>
	Overview	Displays the entire length of the recording. Useful when zooming in to a specific segment of the plot.
	Overlay	<p>The plots can be displayed either as separate charts, with one dataset per chart, or overlaid in a single chart, where two or more datasets are combined for direct comparison.</p> <p>By default, plots are displayed separately. Use this option to switch between separate and overlay.</p>
	Load Last Recorded Data	Reads the data from the last recording, which is saved automatically in the drive.
	Auto-scale Y	When selected, the chart auto-scales the Y-axis for each parameter. This allows visual comparison of values across multiple plots, even if the underlying numeric ranges are different.
	<i>select parameters</i>	<p>Click in the field and begin typing a parameter. A list of available drive parameters is displayed based on the characters typed.</p> <p>Up to 3 parameters can be selected when the chart pane is in the small form. Up to 5 parameters can be selected when the chart panel is expanded to full screen.</p>
	Full screen	The recorder chart expands to fill the entire software screen.
	CSV File	Export the recorded data to a CSV file.
	Delete previous	When selected (red icon), only the latest recording is displayed on the graph. All previous recordings are deleted from the software database before a new recording is saved.
	Delete all	Deletes all recordings in the software database.

10.4 Parameter Monitoring and Analysis

Tuning Parameters

Use the **Tuning Parameters** pane to modify values of parameters to be tested.



Figure 10-6. Tuning Parameters

Recorded Info – Display Settings

Use the **Display Settings** pane to define how recorded data is displayed in the chart.

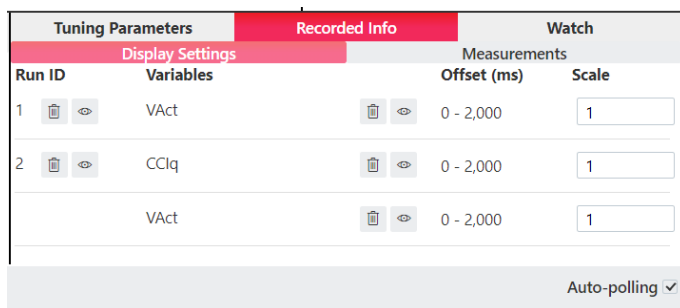

Figure 10-7. Recorded Info – Display Settings

Recorded Info – Measurements

Use the **Measurements** pane to view measurements from the plot of a recording.

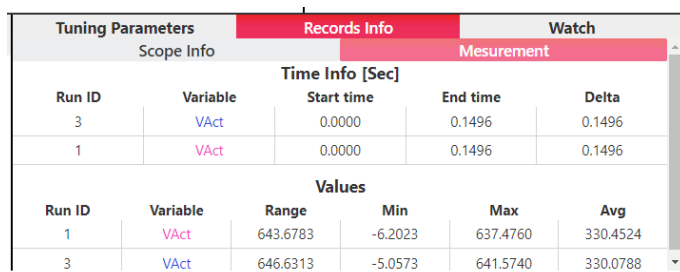

Figure 10-8. Recorded Info – Measurements

Watch Parameters

Use the **Watch** pane to monitor the value of drive parameters.

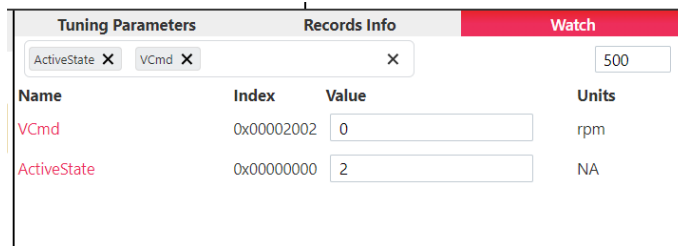

Figure 10-9. Recorded Info – Measurements

10.5 Terminal

The upper part of the Terminal panel contains a pane that allows you to send commands to the drive, and view the drive’s responses.

Use the text box to enter a command.

To empty the contents of the Terminal pane, use the Clear button .

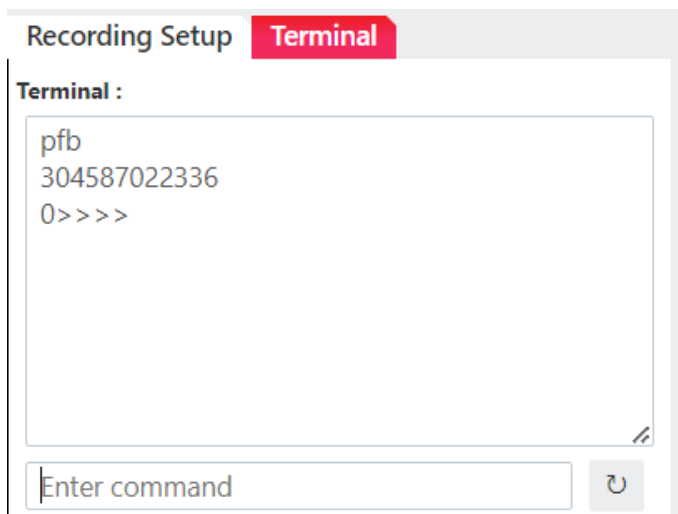

Figure 10-10. Motion Suite – Terminal

10.6 Scripts

The lower part of the Terminal panel contains a script pane that allows you to write, edit and run scripts for the drive.

Any number of scripts can be open and in use.

The script toolbar includes options to Run a script, Save a script, Load (open), a script, and Clear the script pane.

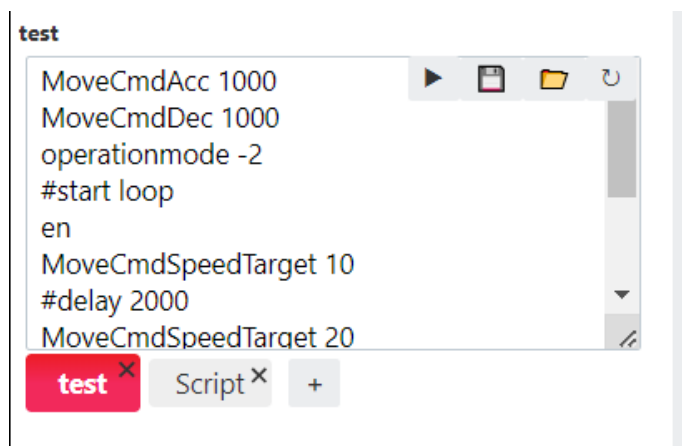

Figure 10-11. Motion Suite – Script

An example of a script is presented below.

```

MoveCmdAcc 1000
MoveCmdDec 1000
operationmode -2
#start loop
en
MoveCmdSpeedTarget 10
#delay 2000
MoveCmdSpeedTarget 20
#delay 2000
MoveCmdSpeedTarget 5
#delay 2000
dis
#delay 2000
#end loop

```

Scripting Commands

#start loop without a number will cause the script to run continuously until stopped by a stop command.

#start loop *n* (where *n* is a number) will cause the script to run the specified number of times, and then stop automatically.

#end loop delineates the end of the block.

#delay is defined in milliseconds, and serves to create a pause between commands.

Use a double forward-slash (//) to delineate a comment in a command line.

11 Network Communication

11.1 CANopen Network

CANopen Network Management

CANopen network nodes and states are controlled by network management (NMT) messages. The following diagram shows the network states and transitions.

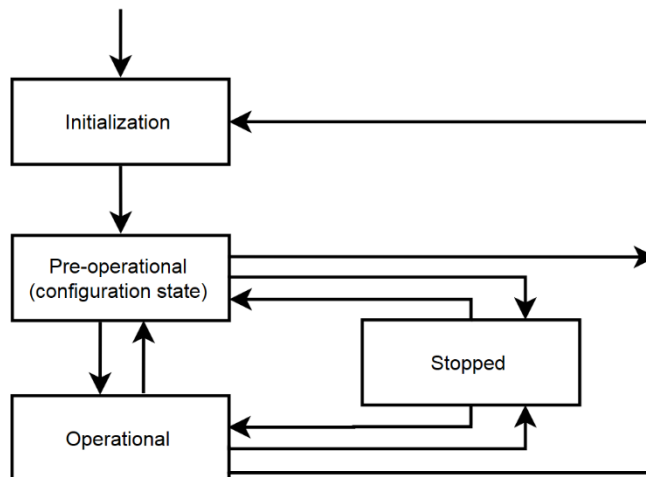

Figure 11-1. CANopen Network Management (NMT) States

- **Pre-operational state.** This state is used primarily for configuration of the CANopen device; therefore, the exchange of process data via PDOs is not possible in this state, and the device cannot be enabled in this state.
- **Operation state.** In this state the transmission of process data via PDOs is possible. This is the only state in which a device can be enabled.
- **Stopped.** A node cannot transmit or receive any other messages in this state. A device cannot be enabled when in this state.

CANopen Node ID

The default node ID for the TIM is **CAN-ID:127**.

To modify the node ID, use the serial parameter **CanNodeID**.

Note: A CANopen/EtherCAT object is not yet implemented for Node ID.

1. Save the new node ID in the TIM.
2. Cycle power to the drive.
3. The new node ID will be set upon power-up.

CANopen Baud Rate

The default baud rate for the TIM is 1000 kbps.

Possible baud rates in CANopen are: 125, 250, 500, 1000.

To modify the baud rate, use the **serial** parameter **CanBaudRate**.

Note: A CANopen/EtherCAT object is not yet implemented for Baud Rate.

1. Save the new baud rate in the TIM.
2. Cycle power to the drive.
3. The new baud rate will be set upon power-up.

11.2 EtherCAT Network

EtherCAT Address

During the start-up phase, the EtherCAT master device sends an auto-addressing telegram to the slave devices – each slave receives an address and auto-increments the address to the next higher number for the following slave. The EtherCAT master then continues to query each EtherCAT slave for details about its properties.

All addressing is performed by the EtherCAT master device according to the EtherCAT standard; there are no address settings for the user to manipulate.

EtherCAT Network Management

EtherCAT network nodes and states are controlled by network management (NMT) messages. The following diagram shows the network states and transitions.

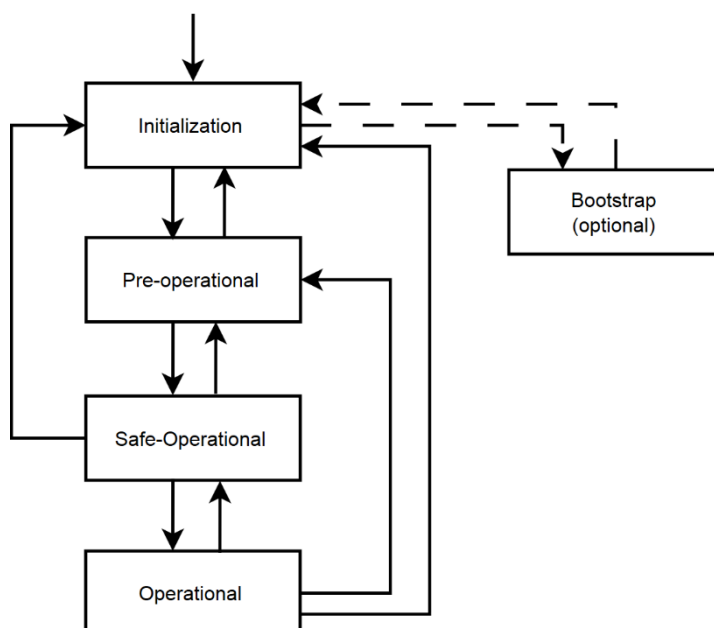

Figure 11-2. EtherCAT Network Management (NMT) States

- **Init.** No communication on the application layer is available. The master has access only to the DL-information registers.
- **Pre-operational.** Mailbox communication on the application layer available, but no process data communication available
- **Safe-operational.** Mailbox communication on the application layer, process (input) data communication available. In SafeOp only inputs are evaluated; outputs are kept in 'safe' state.
- **Operational.** Process data inputs and outputs are valid.
- **Bootstrap.** Optional but recommended if firmware updates are required. No process data communication. Communication only via mailbox on Application Layer. Special mailbox configuration is possible, e.g. larger mailbox size. In this state the FoE protocol is usually used for firmware download

12 Motor Brake Control

Motor brake parameters for the TIM are predefined and cannot be modified by the user.

You can view the values of the brake parameters in the Motion Suite Motor screen.

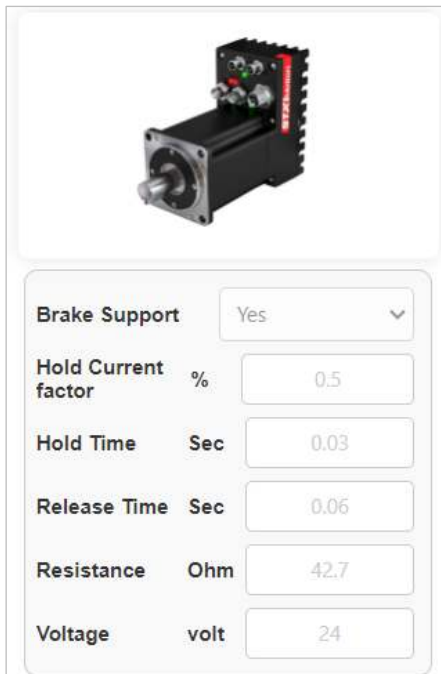

Figure 12-1. Motion Suite brake data in Motor screen

12.1 PWM Motor Brake Control Overview

The servo drive controls the motor brake differently depending on whether a safety motion module (SMM) is installed.

- Without SMM: The drive CPU directly controls the motor brake.
- With SMM: The brake signal is controlled by the SMM.

When any safety function (from the FSoE master, a Safe Digital Input, or the drive itself) requests Safe Brake Control (SBC), the motor brake engages (PWM duty cycle = 0%).

The brake disengages automatically when no SBC request is active.

The behavior for disengaging the motor brake is defined by the serial parameter **BrakeType**. The parameter value is stored in the drive's EEPROM and cannot be changed.

BrakeType	Description	Use
0	Simple on/off switching of the brake voltage. PWM control is not supported.	Drives without SMM
1	PWM-controlled, open-loop mode.	Drives with or without SMM
2	PWM-controlled, closed-loop mode. If used with a SMM, the firmware automatically treats this as BrakeType = 1.	Drives without SMM

12.2 BrakeType 1 (Open-Loop)

In open-loop mode, the drive controls the motor brake by adjusting the PWM duty cycle of the brake output.

The brake current depends on the brake’s resistance and inductance, the brake supply voltage, and the applied PWM duty cycle.

If the drive includes a SMM, the drive sends the PWM duty cycle value to the SMM, which applies it directly to generate the brake signal.

Brake Current Behavior

The motor brake current PWM duty-cycle is described in the following figure.

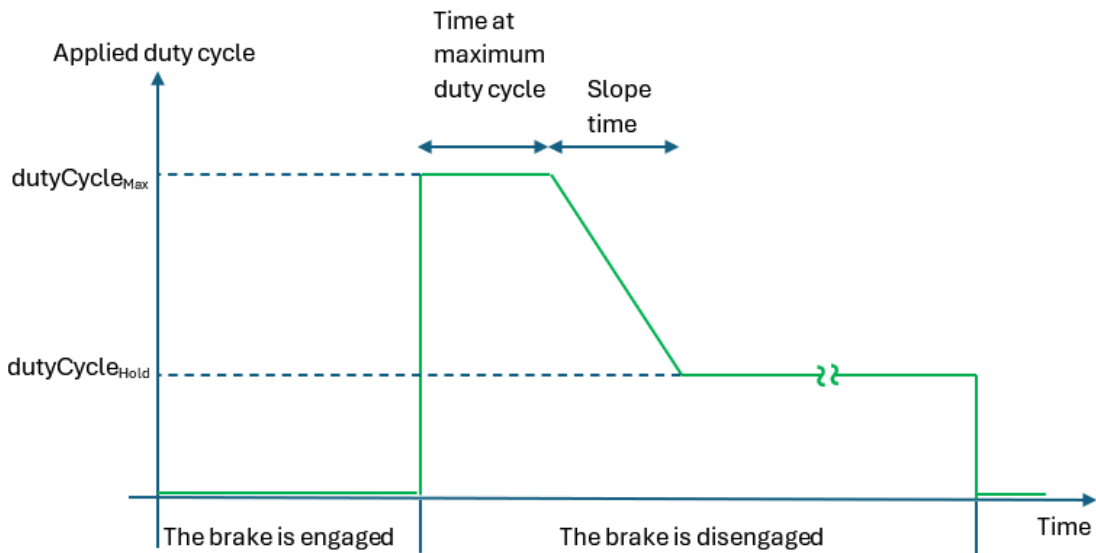

Figure 12-2. Motor brake current PWM duty-cycle

When the brake is activated, the drive first applies a maximum PWM duty cycle for a short period to release the brake. It then gradually reduces the duty cycle until the holding level is reached.

The brake supply type is defined by the parameter **BrakeVoltageSupply**, which determines how the drive compensates for voltage changes.

BrakeVoltageSupply	Description
-1	Not set. Results in a drive fault when enabling.
0	Brake powered from the DC bus voltage. The drive automatically compensates the PWM duty cycle during acceleration or deceleration to maintain stable brake voltage.
> 0	Brake powered from a separate external supply. The drive adjusts the duty cycle based on this fixed voltage value.

Duty Cycle Settings

The maximum duty cycle is limited to 100%.

The holding duty cycle is calculated automatically based on the parameter **BrakeHoldCurrentFactor**.

For drives with an SMM, the holding duty cycle is limited to a maximum of 90%.

Caution.



On drives without a SMM, ensure the brake voltage matches the hardware rating. Connecting a 24 V brake to a 48 V supply can cause damage.

Parameter Settings

Parameter	Typical Setting	Description
BrakeVoltageSupply	0 if the brake is powered from the DC bus. 24, 48, or another fixed value if powered from an external supply.	Defines the brake supply voltage reference used for duty-cycle calculation.
BrakeHoldCurrentFactor	0.4 ... 0.6 (typical range)	Defines the ratio between maximum and holding current. Higher values increase holding torque but also heat generation.
BrakeReleaseTime (if available)	100 – 300 ms	Defines the duration of the initial maximum duty cycle for releasing the brake.

Recommended Values

Use **BrakeVoltageSupply** = 0 for most installations powered from the internal DC bus.

Use a defined voltage value (e.g. 24 V) when the brake has its own external supply.

Verify correct brake release and holding behavior during commissioning.

12.3 BrakeType 2 (Closed-Loop)

Note Closed-loop mode is supported only on servo drives without a safe motion module (SMM). Drives designed for SMM hardware may still report BrakeType = 2, but internally their firmware operates in open-loop PWM mode.

Closed-loop PWM control regulates the motor brake current using internal current feedback. This allows the drive to maintain a precise and stable brake current, independent of voltage or temperature variations. The result is smoother brake release, reduced heat generation, and consistent brake performance.

Advantages of PWM Brake Control

The PWM brake control method provides two key benefits:

- Stable brake current with variable supply voltage.

The drive maintains a consistent brake current even if the brake is powered from an unstable source, such as the internal DC bus. This is useful when the bus voltage fluctuates during acceleration or deceleration, or when the brake's nominal voltage is lower than the bus voltage.

- Reduced holding current and lower heat dissipation.

After the brake is released, the drive can reduce the brake current to a lower holding current, typically as low as 30% of the brake's nominal current.

Since heat generation is proportional to the square of the current (I^2), the brake's thermal load is reduced to approximately 9% of its full-current value:

$$(0.3 \times I_{nom})^2 = 0.09 \times I_{nom}^2$$

This significantly decreases brake heating and overall power consumption.

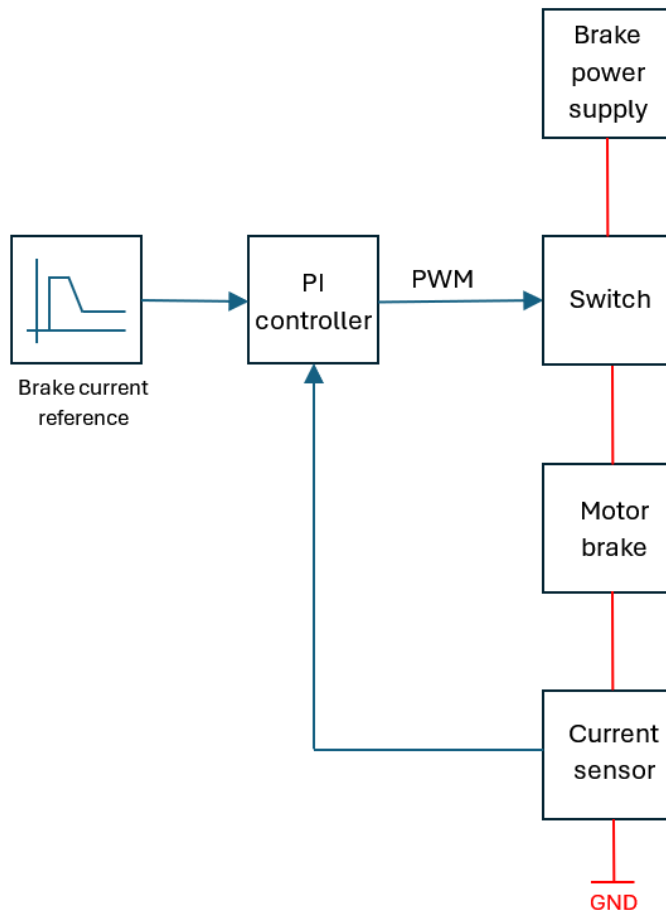

Figure 12-3. Motor brake current PWM duty-cycle

Important Considerations

Reducing the holding current too much can lower the brake's mechanical stability. If the holding current is set too low, the brake may unintentionally engage during operation. In such cases, increase the holding current until the brake remains fully disengaged under all load conditions.

Brake Current Reference

To engage the brake, the PWM output is set to 0%, cutting current flow to the brake coil.

To disengage the brake, the drive supplies the brake's nominal current as defined by the motor brake parameters.

After the brake is fully released, the current can be reduced to a lower holding current to minimize heat generation and power consumption.

The holding current is expressed as a fraction of the brake's nominal current and forms part of the brake current reference profile used by the internal PI controller.

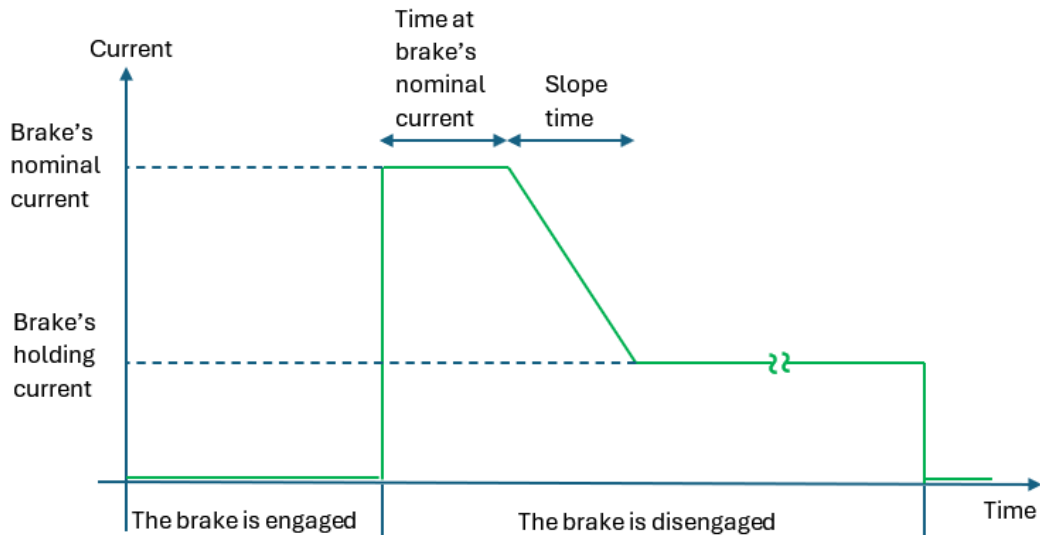

Figure 12-4. Brake current reference

Parameter	Data type	Units	Range	Description
BrakeVoltage	Float	Volt	1 to 100	User-defined, from motor brake datasheet
BrakeResistance	Float	Ohm	1 to 1000	User-defined, from motor brake datasheet
BrakeHoldCurrentFactor	Float	n/a	0.3 to 1.0	User-defined, defines the ratio between holding and nominal current
Time at nominal current	Float	sec	1	Fixed (firmware value). Duration of initial nominal current phase
Slope time	Float	sec	1	Fixed (firmware value). Defines ramp rate of current transition

Calculated Parameters

The drive calculates the following current values automatically:

- Brake nominal current [A]

$$I_{nom} = \frac{BrakeVoltage}{BrakeResistance}$$

- Brake holding current [A]

$$I_{hold} = I_{nom} \times BrakeHoldCurrentFactor$$

These calculated values determine the current reference profile applied by the internal control loop.

PI Controller Operation

The brake current is regulated by a PI (Proportional–Integral) controller running in real time:

- Execution rate: every 125 μ s (equivalent to 8 kHz)
- PWM switching frequency: 16 kHz

The PI controller continuously compares the actual brake current with the current reference and adjusts the PWM duty cycle accordingly.

This ensures accurate control of the brake current and stable brake performance under varying load and voltage conditions.

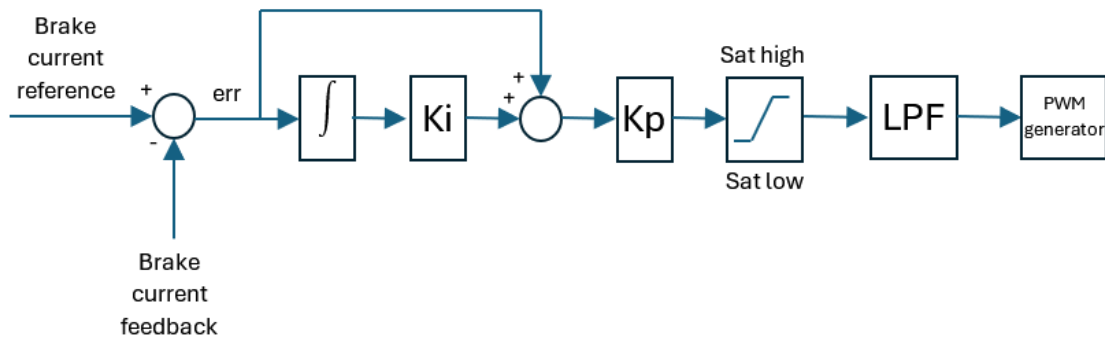

Figure 12-5. PI Controller

The following parameters define the PI controller behavior:

Parameter	Data type	Units	Range	Description
Kp	Float	PWM/Amp		Calculated internally (firmware value). Proportional gain factor.
Ki	Float	Hz	100	Fixed (firmware value). Integral gain frequency.
Sat high	Float	PWM	100%	Fixed (firmware value). Upper limit of controller output.
Sat low	Float	PWM	0%	Fixed (firmware value). Lower limit of controller output.
LPF cutoff frequency	Float	Hz	1000	Fixed (firmware value). Low-pass filter frequency for current feedback signal.

12.4 Additional Motor Brake Parameters

The following parameters provide additional configuration and diagnostic options for the motor brake. They are typically used during setup, testing, or maintenance procedures.

Brake Support

Parameter	Data Type	Unit	Range	Access	Description
BrakeSupport	INT16	–	0 ... 2	R/W	Defines how the Drive controls the motor brake.

Value	Function	Description
0	Disengage brake manually	Opens (disengages) the brake according to the selected BrakeType , regardless of the drive's enable/disable state. Useful for maintenance or manual movement of the axis.
1	Automatic control	Default setting. Allows the drive firmware to control the brake automatically based on the drive's operating state.
2	Engage brake manually	Closes (engages) the brake regardless of the drive's enable/disable state. Useful for brake test procedures.

Typical Use

- Use 0 for mechanical service or manual axis movement.
- Keep 1 during normal operation.
- Use 2 for brake engagement testing.

Brake Hold Time

Parameter	Data Type	Unit	Range	Access	Description
BrakeHoldTime	Float	sec	0 ... 10	R/W	Time during disable transition before motor current is turned off.

When the drive transitions from enabled → disabled, it engages the motor brake and holds it for the duration of **BrakeHoldTime** before the motor windings are de-energized. This ensures the mechanical load is secured before torque is removed.

Set **BrakeHoldTime** long enough to allow the brake to close fully before motor torque is released.

Brake Release Time

Parameter	Data Type	Unit	Range	Access	Description
BrakeReleaseTime	Float	sec	0 ... 10	R/W	Time delay during enable transition before motion is allowed.

When the drive transitions from disabled → enabled, it first energizes the motor windings through the control loops, then disengages (opens) the brake according to the selected **BrakeType**.

During the defined **BrakeReleaseTime**, no motion command is permitted.

Adjust **BrakeReleaseTime** to ensure the brake is fully released before issuing motion commands.

IBrake

Parameter	Data Type	Unit	Access	Description
IBrake	Float	A	R/O	Displays the instantaneous brake current.

IBrake provides a live reading of the actual current flowing through the motor brake.

- On units without an SMM, the current is measured directly by the drive CPU.
- On units with an SMM, the measurement is performed by the SMM itself.

Use **IBrake** for diagnostic purposes to verify correct brake operation, current regulation, and parameter tuning during commissioning.

12.5 Motor Brake Parameters Summary

The following tables summaries of the motor brake parameters mentioned and described in this chapter.

Parameter	ECAT/CAN Object	Data Type	Comment
BrakeType	N/A	INT16	Defines the method of the motor brake control.
BrakeSupport	0x210F:0x01	INT16	0 = brake always disengaged 1 = according to enable/disable 2 = brake always engaged
BrakeHoldCurrentFactor	0x2040:0x00	Float	Factor to change PWM duty cycle, used for BrakeType 1 and 2.
BrakeVoltage	0x210F:0x05	Float	Data-sheet value, used for BrakeType 1 and 2.
BrakeVoltageSupply	0x210F:0x07	INT16	Actual voltage of the brake's power supply in the application.

Parameter	ECAT/CAN Object	Data Type	Comment
BrakeResistance	0x210F:0x06	Float	Data-sheet value, used for BrakeType 2.
IBrake	0x210F:0x04	Float	Actual current of motor brake.
BrakeHoldTime	0x210F:0x03	Float	Time delay during disable transition.
BrakeReleaseTime	0x210F:0x02	Float	Time delay during enable transition.
BusVoltageSense	0x204D:0x00	INT16	Actual DC bus voltage, used for BrakeType 1.

12.6 Holding Brake Data

The brake works according the closed-circuit current principle. To disengage the brake, a brake nominal current must flow through the brake; this is controlled by the drive.

If the power supply is interrupted, as in an emergency stop or a power outage, the brake stops the motor shaft rotation.

When using the holding brake, the TIM requires a separate 24/48 VDC power supply at connector C2, pins 1 and 2 (refer to section *Electrical Interfaces*).

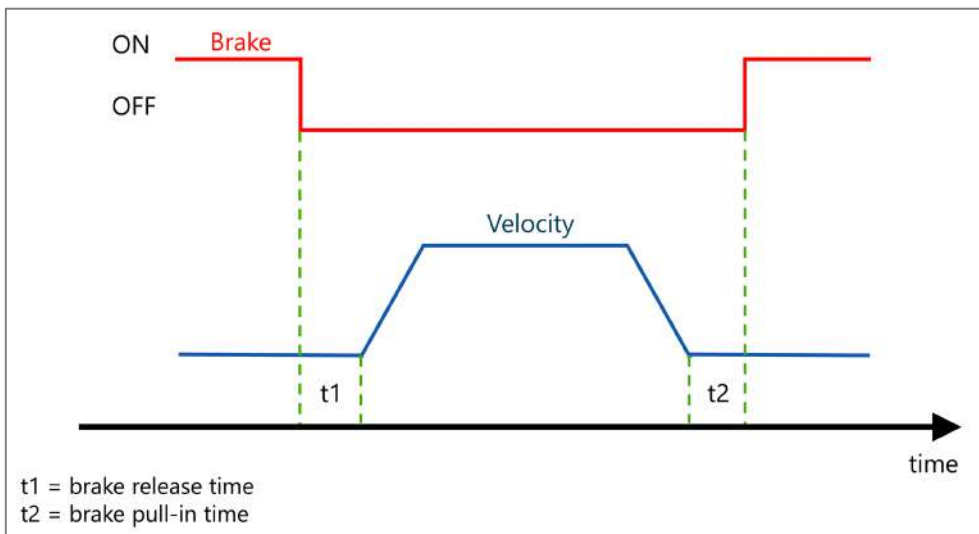

Figure 12-6. Motor brake control

Table 12-1. Motor Brake Specifications

		40 mm Flange	60 mm Flange	80 mm Flange	110 mm Flange	130 mm Flange
Voltage	VDC	24 ±10%	24 ±10%	24 ±10%	24 ±10%	24 ±10%
Power	W	5.3	7.4	13.5	16.8	16.9
Static Torque Min.	Nm	0.32	1.3	4.0	12	15
Resistance (20°C)	Ω	108 ±10%	78 ±10%	42.7 ±10%	34 ±10%	34 ±10%
Release Voltage	V	> 1.5	> 1	> 1.2	> 1.5	> 1.0
Pull-in Voltage	V	≤ 16.8	≤ 16.8	≤ 16.8	≤ 18	≤ 16.8
Release time	ms	≤ 20	30	30	≤ 60	≤ 60
Pull-in time	ms	≤ 35	50	60	≤ 100	≤ 100

Note In vertical axis applications, it is necessary to implement additional safety measures, such as, but not only, mechanical interlocks, redundant brakes.

13 Overload Protection

The overload algorithm protects the TIM drive and motor from overheating due to excessive current by limiting the rms value of the current command so that it does not exceed the rms value of the drive's rated current or the motor's rated current. It is set separately for the drive and for the motor.

OverloadMode (object 0x2022 / subindex 1)

0 = Generates an overload fault when the overload starts limiting the current command

1 = Limits the current command without generating an overload fault

Motor parameters that affect the motor overload algorithm behavior:

MotorIPeak	Object 0x200E, subindex 7. Motor peak current [A]
MotorIRated	Object 0x200E, subindex 6. Motor rated current [A]
OverloadMotorTime	Object 0x2022, subindex 3. Maximum time for the current to be at MotorIPeak [sec]

Drive parameters that affect the drive overload algorithm behavior:

DriveIPeak	Object 0x2020, subindex 2. Drive peak current [A]
DriveIRated	Object 0x2020, subindex 1. Drive rated current [A]
OverloadDriveTime	Object 0x2022, subindex 2. Maximum time for the current to be at DriveIPeak [sec]

When a motor is selected from the Motion Suite database, its current overload parameters are predefined and automatically loaded to the drive. Parameters that affect the overload algorithm of the drive are defined by the manufacturer and should not be changed by the user. However, if you wish to change these parameters for any reason, contact Technical Support.

The overload algorithm generates an overload current limit (DriveOverLoadI, object 0x2022 / subindex 5, and MotorOverLoadI, object 0x2022 / subindex 6).

The initial value of this overload current limit, which is also the maximum value, is greater than the peak current. When the actual current is higher than the rated current, the overload current limit is decreased proportionally to the difference between the actual current and the rated current. When the actual current is lower than the rated current, the overload current limit is increased proportionally to the difference between the rated current and the actual current, up to its maximum value. The overload current limit may limit the current command (Icmd).

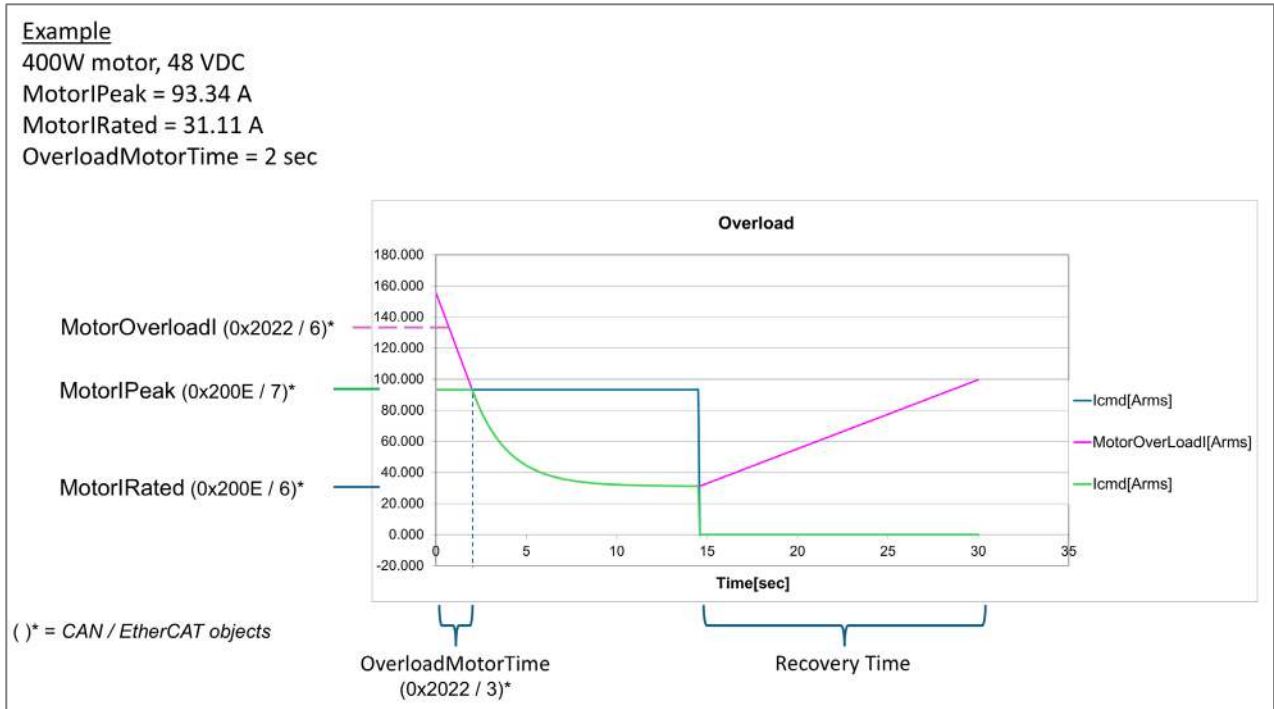

Figure 13-1 Example of TIM overload behavior

14 Digital Inputs and Outputs

The digital inputs and outputs can be configured in the Motion Suite software.

In the navigation menu, select Communication > **Configuration** > IO.

14.1 Serial

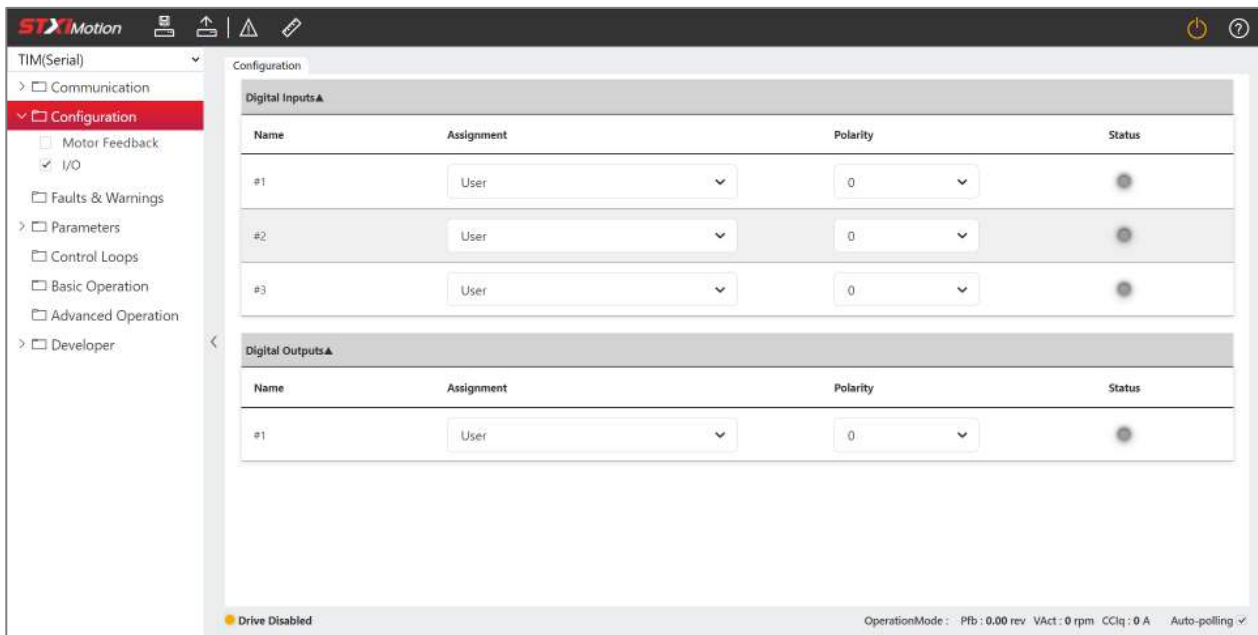

Figure 14-1 Motion Suite – I/O configuration

Digital Inputs

The **Digital Inputs** screen enables you to configure functionality and polarity of the digital inputs, and to monitor the state of the digital inputs.

Element	Description	Serial Parameters
Name	Identifies the specific input.	
Assignment	Defines the functionality of the digital input. 1 = User defined 2 = Position limit 3 = Negative limit 4 = Home switch	DigInput1Assign DigInput2Assign DigInput3Assign
Polarity	Defines the polarity of a digital input. 0 = Not inverted 1 = Inverted As a result of inversion, the Status graphic element in the software changes color.	DigInput1Polarity DigInput2Polarity DigInput3Polarity

Element	Description	Serial Parameters
Status	A graphic element that toggles between green and gray to reflect the on and off states of the actual input.	DigInput1 DigInput2 DigInput3

Digital Outputs

The **Digital Inputs** pane enables you to configure functionality and polarity of the digital output, and to monitor the state of the digital output.

Element	Description	Serial Parameters
Name	Identifies the specific output.	
Assignment	Defines the functionality of the digital output. 0 = Not used 1 = User defined 2 = Drive disabled 3 = Drive enabled	Out1Assign
Polarity	Defines the polarity of a digital output. 0 = Not inverted 1 = Inverted As a result of inversion, the Status graphic element in the software changes color.	Out1Polarity
Connector Pin Number	Indicates the pin number of the output on interface C1.	
Status	A graphic element that toggles between green and gray to reflect the on and off states of the actual output.	DigOutput1

14.2 CANopen/EtherCAT

Input and output functionality is implemented in the TIM according to the CAN standard.

- Object 60FDh – Inputs
- Object 60FE – Outputs

Digital Inputs – CANopen

Object 60FDh is organized bit-wise.

Bit	Field	Bit Value	Definition
0	Negative limit switch	0	Negative limit switch not reached
		1	Negative limit switch reached
1	Positive limit switch	0	Negative limit switch not reached
		1	Negative limit switch reached
2	Home switch	0	Home switch not reached
		1	Home limit switch reached
3	Reserved/Interlock	0	Not applicable
4–15	–		Not applicable
16-31	Manufacturer-specific: bit 16 – digital input 1 bit 17 – digital input 2 bit 18 – digital input 3	0	Function is not activated
		1	Function is activated

Digital Outputs - EtherCAT

Object 60FEh is organized bit-wise.

The object includes sub-indices.

	Field	Bit Value	Definition
Sub-index 01	Set brake	0	Switch off / do not set brake
		1	Switch on / set brake
Sub-index 01	Reserved	0	Reserved
Sub-index 01	Manufacturer-specific	0	Switch off
		1	Switch on
Sub-index 02	Each bit	0	Disable output
		1	Enable outputs

15 Firmware Upgrade

Firmware Upgrade via RS232/Motion Suite

Drive firmware is downloaded to drive through a serial connection and the Motion Suite software.

Note Firmware download over CAN or EtherCAT is not yet supported.

Preparation

1. Download the required firmware file from the STXI Motion website, or contact Technical Support. The firmware file has the extension **bHex** or **Hex**.
2. Read the release note or other documentation supplied with the new firmware.
3. Before upgrading the firmware, it is recommended that you backup the drive parameters, since parameter settings may be modified during the upgrade process. After the upgrade is completed, the parameters can be restored.

To backup parameters from drive:

- a. Open Motion Suite.
- b. In the navigation menu, select **Parameters**.
- c. At the top of the Parameters screen, select **Export Parameters**.

Export Parameters saves all the parameters in the drive to a CSV file, and automatically downloads the file to the **Download** folder on your PC. You can rename the file and store it in any other location on your PC.

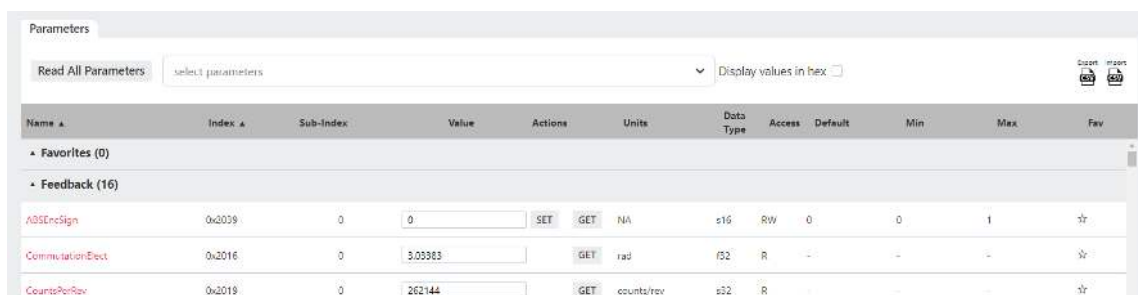

The screenshot shows the 'Parameters' screen in Motion Suite. At the top, there is a 'Read All Parameters' button and a search field labeled 'select parameters'. To the right, there is a 'Display values in hex' checkbox. Below this is a table with columns: Name, Index, Sub-Index, Value, Actions, Units, Data Type, Access, Default, Min, Max, and Fav. The table is filtered to show 'Feedback (16)' parameters. Three parameters are visible:

Name	Index	Sub-Index	Value	Actions	Units	Data Type	Access	Default	Min	Max	Fav
ABSEncSign	0x2039	0	0	SET GET	NA	s16	RW	0	0	1	☆
CommutationEect	0x2016	0	3.03383	GET	rad	f32	R	-	-	-	☆
CountsPerRev	0x2019	0	262144	GET	counts/rev	s32	R	-	-	-	☆

Figure 15-1 Motion Suite – Parameters

Procedure

1. Before downloading firmware to the TIM, make sure the drive is disabled.
2. From the Motion Suite toolbar, select **Download Firmware**.
3. At the prompt, Select **Load File**.
4. Browse to and select the new firmware file, and click **Open**.
5. Select **Download**.

Downloading the firmware file to the drive takes 1–2 minutes.

Resuming Operation

1. Confirm that the new firmware has been downloaded to drive. Open the Motion Suite Connections screen, and check the Firmware version displayed in the Product Info pane:



Figure 15-2 Motion Suite – Firmware version

2. Restore the saved parameters to the drive.
 - a. At the top of the Parameters screen, select **Import Parameters**.
 - b. At the prompt, select **Upload file**.
 - c. Browse to and select (Open) the CSV file you saved on your PC.
 - d. At the prompt, select **Import Parameters**.
3. Check the version release notes.
4. Set any parameters that may have been added in the new version.

16 Troubleshooting

16.1 LEDs

One tri-color LED serves as a drive status indicator.

Four LEDs serve as fieldbus indicators.

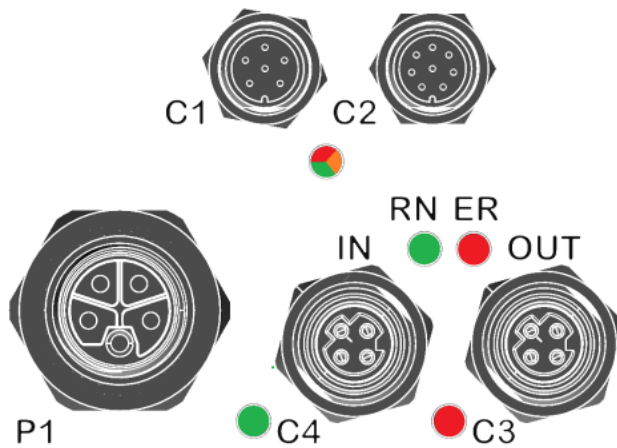

Figure 16-1 Communication and Drive Status Indicator LEDs

Link Activity Status – LEDs C4 and C3 – EtherCAT only

Color	LED state	Description
Green (C4) Red (C3)	Off	No link
	Blinking	Link and activity
	On	Link without activity

Drive Status – Tri-colored LED – CANopen and EtherCAT

Power Up (boot)

Color	LED state	Description
Green	Blinking	Immediately after power up. Evaluating checksum of the application firmware.
Orange	Blinking	Immediately after power up. Evaluating checksum of a new (recently downloaded) application firmware within a backup sector.
Orange	Blinking (other)	Immediately after power up and before application firmware starts running. Indicates a reprogramming sequence after firmware download.
Orange	Flashing	Application firmware checksum failure. Drive requires repair. (1s on > 1s off > 1s on > 1s off > 1s on > 3s off.)

Operational

Color	LED state	Description
Green	On	The TIM is enabled. No faults.
Green	Flashing	The TIM is disabled. No faults. (1000 ms on, 1000 ms off).
Red	On	A fault has been detected and needs attention. The LED remains lit until the error is resolved.
Red	Flashing	STO disconnected. (1000 ms on, 1000 ms off).
Red	Blinking	STO one channel diagnostic fault. (300 ms on, 300 ms off).
Red/Orange	Blinking	Watchdog. (300 ms red, 300 ms orange)

Run Status – RN – CANopen

Color	LED State	Slave State	CANopen Description
Green	On	Operational	The device is in Operational state.
Green	Blinking	Pre-operational	The device is in Pre-operational state.
Green	Single flash	Stopped	The device is in Stopped state.

Error Status – ER – CANopen

Color	LED State	Error Name	CANopen Description
Red	Off	No error	The device is in working condition
Red	On	Bus off	The CAN controller is bus off
Red	Single flash	Warning limit reached	At least one of the error counters of the CAN controller has reached or exceeded the warning level (too many error frames).
Red	Double flash	Error control event	A guard event (NMT-slave or NMT-master) or a heartbeat event (heartbeat consumer) has occurred.

Run Status – RN – EtherCAT

Color	LED State	Slave State	EtherCAT Definition
Green	On	Operational	The device is in Operational state.
Green	Off	Initialization	The device is in Initialization state.
Green	Blinking	Pre-operational	The device is in Pre-operational state.
Green	Single flash	Safe-operational	The device is in Safe-operational state.

Error Status – ER – EtherCAT

Color	LED State	Error Name	EtherCAT Definition
Red	Off	No error	EtherCAT communication of the device is in working condition.
Red	On	Application controller failure	A critical communication or application controller error has occurred.
Red	Single flash	Local Error	Slave device application has changed the EtherCAT state autonomously due to local error (Error Indicator bit is set to 1 in AL Status register.) <i>Unsolicited state change.</i>
Red	Double flash	Process data watchdog timeout/ EtherCAT watchdog timeout	An application watchdog timeout has occurred.
Red	Blinking	Invalid Configuration	General configuration error
Red	Flickering	Booting error	Booting error was detected. Init state reached, but Error Indicator bit is set to 1 in AL Status register.

16.2 Faults and Warnings

Faults and Warnings Screen

The Faults screen displays a list of all faults and warnings currently in effect.



The color of the Faults and Warnings button in the toolbar indicates whether any warnings or faults exist in the TIM.

- White indicates there are no faults or warnings in the drive.
- Orange indicates warnings.
- Red indicates faults.

Click the button to open a small message pane that displays the faults and warnings in effect, and includes an option to clear faults.

Alternately, use the **Clear Faults** button at the top of the screen.

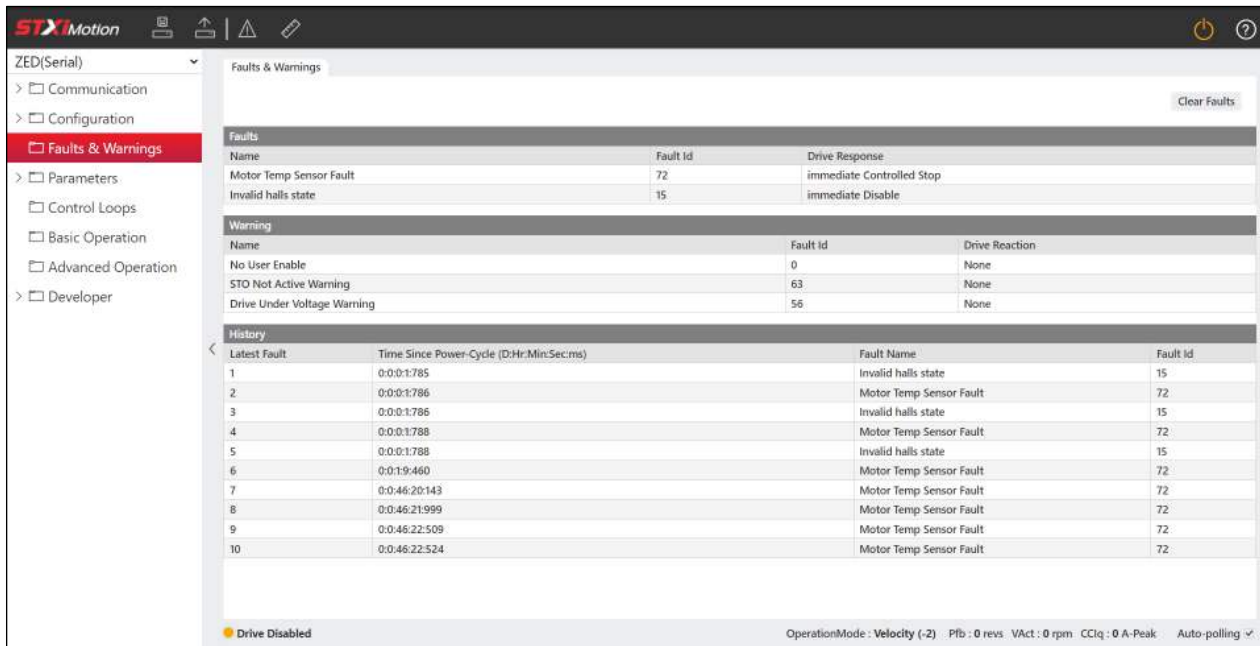

Figure 16-2. Motion Suite – Faults & Warnings

Warnings remain displayed until cleared by **Clear Faults**, provided the condition that caused the warning has been removed.

After a fault condition is removed, the fault remains latched until cleared by **Clear Faults**. Once all faults are cleared, the drive can be enabled.

Faults/Warnings

Name	A short description of the fault or warning.
Fault ID	The system ID of the fault or warning.
Drive Response	Description of drive behavior as a result of the fault. Typically, the response is an immediate disable or an immediate controlled stop.

Fault History

Latest Fault	List of the last 20 faults reported from the drive, since the fault buffer was last cleared.
Time Since Power-Cycle	The controller internal runtime at which the fault occurred.
Fault Name	A short description of the fault.
Fault ID	The system ID of the fault.

Faults and Warning Codes

The following tables list the warnings and faults issued through serial communication.

Refer also to object **603Fh** (Error Code) and object **2032h** (Fault word) in the *TIM-ZED EtherCAT/ CANopen User Manual*.

The TIM uses standard CAN error codes whenever possible. If a standard code is not defined, the TIM uses code 0xFF01 for the error.

Warnings

Warnings are not considered faults and do not disable operation. The system automatically clears the warning state when the condition that generated the warning no longer exists.

Fault ID#	Serial String	Fault Word object 2032h (sub-index)	Fault Word Error Mask	Error Code object 603Fh (sub-index 0x00)	Description
0	WRN: No User Enable	0x01	0x0000 0001	0xFF01	Drive is Disabled. Indicates the user enable command (serial command En or the relevant bits in fieldbus control word) is missing.
43	WRN: Drive Overload Warning	0x02	0x0000 0800	0x2351	This warning is issued when the drive's overload current (serial command DriveOverLoadI) is slightly above drive's peak current (serial command DriveIPeak), and there is no Drive Overload fault
45	WRN: Motor Overload Warning	0x02	0x0000 2000	0x2351	This warning is issued when the motor's overload current (serial command MotorOverLoadI) is slightly above motor's peak current (serial command MotorIPeak), and there is not Motor Overload fault.
46	WRN: Drive Over Temp Warning	0x02	0x0000 4000	0xFF01	This warning is issued when the measured drive temperature (serial command DriveTemp) reaches 5°C below the drive temperature threshold (serial command DriveTempThreshold); that is, 5°C before the drive temperature fault occurs.

Fault ID#	Serial String	Fault Word object 2032h (sub-index)	Fault Word Error Mask	Error Code object 603Fh (sub-index 0x00)	Description
49	WRN: Corrupted Faults Log File	0x02	0x0002 0000	0xFF01	This warning occurs if the faults log data from the flash memory fails to load (due to, for example, a corrupted file, an excessively large file, a file containing too many faults, or unknown/invalid data content). The fault can be cleared by a successful file erasure (serial command ClearFaultsLog).
56	WRN: Drive Under Voltage Warning	0x02	0x0100 0000	0x3120	The warning is issued when the measured bus voltage (serial command BusVoltageSense) drops to within 2V of the undervoltage threshold (serial command UnderVoltageThreshold); that is 2V before the undervoltage fault occurs.
58	WRN: Heatsink Over Temp Warning	0x02	0x0400 0000	0x4110	The warning is issued when the measured heatsink temperature (serial command HeatsinkTemp) reaches 5°C below the heatsink temperature threshold (serial command HeatsinkTempThreshold); that is, 5°C before the heatsink temperature fault occurs, and this warning is enabled (serial command HeatsinkMode is 0). This warning can be ignored when serial command HeatsinkMode is 1.
63	WRN: STO Not Active Warning	0x02	0x8000 0000	0xFF01	This warning is issued when STO voltage is removed while the drive is enabled.
71	WRN: Motor Over Temp Warning	0x03	0x0000 0080	0x4110	The warning is issued when the measured motor temperature (serial command MotorTemp) reaches 5°C below the motor temperature threshold (serial command MotorTempThreshold); that is, 5°C before the motor temperature fault occurs.

Fault ID#	Serial String	Fault Word object 2032h (sub-index)	Fault Word Error Mask	Error Code object 603Fh (sub-index 0x00)	Description
78	WRN: No Remote Enable	0x03	0x0000 4000	0xFF01	This warning is issued when one of the digital input functionalities is assigned to mode 5 (serial commands DigInput1Assign or DigInput2Assign or DigInput3Assign), and the input is at low level.
86	WRN: Pos SW Position Limit Detected	0x03	0x0040 0000	0xFF01	Positive software limit switch is active.
87	WRN: Neg SW Position Limit Detected	0x03	0x0080 0000	0xFF01	Negative software limit switch is active.
88	WRN: SW Limits Inhibited: No Homing	0x03	0x0100 0000	0xFF01	Software limit switches are enabled only if homing has been performed.
94	WRN: Numerical PFB limit warning	0x03	0x4000 0000	0xFF01	Position feedback variable (64 bits) is approaching its numerical limit.
100	WRN: MTS Overload Warning	0x04	0x0000 0010	0xFF01	This warning is issued if the execution time of the main interrupt service routine (ISR) exceeds a threshold. The threshold value may vary in different firmware versions.
102	WRN: Safety Module Warning	0x04	0x0000 0040	0xFF01	This warning is issued if the safety module (if it exists) reports an internal warning.
107	WRN: Faults Log File Open Failed	0x04	0x0000 0800	0xFF01	This warning is issued if the fault log file failed to open. This warning is persistent.
108	WRN: Faults Log File Read Error	0x04	0x0000 1000	0xFF01	This warning is issued if an error occurred while trying to read the fault log file. This warning is persistent.
109	WRN: Faults Log File Size Error	0x04	0x0000 2000	0xFF01	This warning is issued if the size of the fault log file is larger than expected. This warning is persistent.

Fault ID#	Serial String	Fault Word object 2032h (sub-index)	Fault Word Error Mask	Error Code object 603Fh (sub-index 0x00)	Description
110	WRN: Faults Log Save Failed	0x04	0x0000 4000	0000,4000	Whenever a new fault is detected, it is logged into a fault history file. If the operation of saving the file to the internal flash fails, this fault is generated. The user should consider erasing the Fault log file for faults history file integrity.
111	WRN: BiSS Timing Event	0x04	0x0000 8000	0xFF01	When using a BiSS feedback device, the drive and feedback communicate continuously. If a communication transaction is not completed on time, this will be noted by the BiSS timing warning. If the warning occurs when feedback is disconnected after power up, this is considered normal behavior. Otherwise, contact cTechnical Support.
116	WRN: Safety module fault	0x04	0x0010 0000	0xFF01	This warning is issued when the safety module, if it exists, reports an internal fault and the drive is in the disabled state but a safety module fault has not been reported (#103 FLT: Safety module fault has not yet occurred.). Corrective measure: Try to acknowledge the safety card fault via the error acknowledge bit within the FSoE data. Set the bit from 0 to 1 and then back to 0.

Faults

Faults occur when settings or conditions may adversely affect TIM operation or damage the drive.

Faults automatically disable the drive, and the fault status is indicated by LEDs and/or software messages.

The drive fault status is generally latched, and the drive cannot be enabled until the fault status is explicitly cleared. The fault status cannot be cleared until the fault condition no longer exists.

Fault ID#	Serial String	Fault Word object 2032h (sub-index)	Fault Word Error Mask	Error Code object 603Fh (sub-index 0x00)	Description	TIM Response
1	FLT: Current Offsets Invalid	0x01	0x0000 0002	0xFF01	This fault is in effect until the drive completes the offset compensation calculation for the A2D converters, which sample the motor phase U, V and W currents.	Immediate disable
7	FLT: Overload Design Failed	0x01	0x0000 0080	0xFF01	This fault occurs in two instances: If the drive is enabled and the drive's peak current (serial command DriveIPeak) is equal to or below the drive's rated current (serial command DriveIRated). This fault occurs if the drive is enabled and the motor's peak current (serial command MotorIPeak) is equal to or below the motor's rated current (serial command MotorIRated).	Immediate disable
15	FLT: Invalid Halls State	0x01	0x0000 8000	0x7300	This fault is applicable to motors with an incremental encoder and Hall sensor feedback. This fault occurs when the three Hall switches are all either logically high or logically low, which are invalid Hall states.	Immediate disable
16	FLT: Invalid Halls Switch	0x01	0x0001 0000	0x7300	This fault is applicable to motors with an incremental encoder and Hall sensor feedback. This fault occurs when an invalid Hall switch is detected.	Immediate disable

Fault ID#	Serial String	Fault Word object 2032h (sub-index)	Fault Word Error Mask	Error Code object 603Fh (sub-index 0x00)	Description	TIM Response
22	FLT: Manufacturer Info Read Error	0x01	0x0040 0000	0xFF01	This fault indicates that reading manufacturer data from non-volatile memory has failed. This fault cannot be cleared by the Clearfaults command. Try clearing the fault by power cycling the drive. If the fault persists, contact STXI Motion Technical Support.	Immediate disable
23	FLT: Manufacturer Info Write Error	0x01	0x0080 0000	0xFF01	This fault indicates that writing manufacturer data to non-volatile memory or erasing manufacturer data from non-volatile memory has failed. This fault cannot be cleared by the Clearfaults command. Try clearing the fault by power cycling the drive. If the fault persists, contact STXI Motion Technical Support.	Immediate disable
24	FLT: PWM Driver Error	0x01	0x0100 0000	0xFF01	This fault occurs in several instances: If the gate driver type could not be read from the manufacturer data in non-volatile memory (serial command GateDriveType). If the gate driver type is unknown to the firmware (serial command GateDriveType). If configuration of the gate driver (e.g., via SPI interface) has failed. This fault cannot be cleared by the Clearfaults command. Try clearing the fault by power cycling the drive. If the fault persists, contact STXI Motion Technical Support.	Immediate disable
25	FLT: Fieldbus Sync Loss	0x01	0x0200 0000	0xFF01	This fault occurs if the drive loses synchronization with the fieldbus master during enable. Refer to object 210Bh PLL Information Parameters.	Immediate controlled stop

Fault ID#	Serial String	Fault Word object 2032h (sub-index)	Fault Word Error Mask	Error Code object 603Fh (sub-index 0x00)	Description	TIM Response
26	FLT: Corrupted Parameters File	0x01	0x0400 0000	0xFF01	This fault occurs if the loading of parameter data from the flash memory fails due to a missing file, a corrupted file, or unknown/invalid data content. The fault can be cleared by saving the parameter (serial command SaveParams 1).	Immediate disable
27	FLT: Motor Over Speed	0x01	0x0800 0000	0x7310	This fault occurs if the drive is enabled and the actual velocity (serial command VAct) briefly exceeds the overspeed threshold (5 consecutive samples). The overspeed threshold is the minimum of the user overspeed setting (serial command Overspeed), and 1.2 times the maximum motor speed (serial command MotorSpeed).	Immediate disable
28	FLT: Drive Over Current	0x01	0x1000 0000	0x2220	This fault occurs if the CPU reads a momentary or latched over-current hardware indication on a dedicated CPU input pin. At least 1 second should elapse from the time over-current fault was detected until there is an attempt to clear it. Only 3 over-current fault clears are allowed. The fourth over-current fault cannot be cleared. Try clearing the fault by power cycling the drive.	Immediate disable

Fault ID#	Serial String	Fault Word object 2032h (sub-index)	Fault Word Error Mask	Error Code object 603Fh (sub-index 0x00)	Description	TIM Response
29	FLT: Drive Over Voltage	0x01	0x2000 0000	0x3110	<p>This fault occurs in two instances.</p> <p>(1) If the measured bus voltage (serial command BusVoltageSense) exceeds the overvoltage threshold (serial command OverVoltageThreshold). OverVoltageThreshold is the minimum of:</p> <ul style="list-style-type: none"> ◆ General TIM maximum voltage rating of the drive (hardware-dependent). ◆ 1.5 times the motor voltage (serial command MotorVoltage). ◆ 1.75 times the TIM drive voltage (serial command Vbus). <p>(2) By a hardware signal (if that feature is enabled).</p>	Immediate disable
30	FLT: Drive Over Temp	0x01	0x4000 0000	0x4110	<p>This fault occurs if the measured drive temperature (serial command DriveTemp) exceeds the drive temperature threshold (serial command DriveTempThreshold).</p>	Immediate controlled stop
31	FLT: Motor Over Temp	0x01	0x8000 0000	0x4110	<p>This fault occurs if the motor has a temperature sensor, and the measured motor temperature (serial command MotorTemp) exceeds the motor temperature threshold (serial command MotorTempThreshold).</p>	Immediate controlled stop
32	FLT: PE Max Exceeded	0x02	0x0000 0001	0x8611	<p>This fault occurs if the drive is enabled and the following error of the position loop (serial command Pe) exceeds the user-defined following error threshold (serial command PeMax).</p> <p>A PeMax value of 0 deactivates this fault.</p> <p>Tuning the control loops will affect generation of this fault.</p>	Immediate controlled stop

Fault ID#	Serial String	Fault Word object 2032h (sub-index)	Fault Word Error Mask	Error Code object 603Fh (sub-index 0x00)	Description	TIM Response
33	FLT: MT6835 Enc Over Speed Reached	0x02	0x0000 0002	0x7300	<p>This fault occurs when, for 3 consecutive cycles of 62.5 μs (3 x 62.5 μs), the MT6835 feedback device reports a Rotation Overspeed Warning in its STATUS register.</p> <p>This error is reported by the feedback device itself. The maximum rotation speed of the MT6835 feedback device is 120,000 rpm.</p> <p>This fault cannot be cleared by the Clearfaults command. Try clearing the fault by power cycling the drive. If the fault persists, contact STXI Motion Technical Support.</p>	Immediate disable
34	FLT: MT6835 Enc Weak Magnetic Field	0x02	0x0000 0004	0x7300	<p>This fault occurs when, for 3 consecutive MTS cycles of 62.5 μs (3 x 62.5 μs), the MT6835 feedback device reports a Weak Magnetic Field Warning in its STATUS register.</p> <p>This error is reported by the feedback device itself.</p> <p>This fault cannot be cleared by the Clearfaults command. Try clearing the fault by power cycling the drive. If the fault persists, contact STXI Motion Technical Support.</p>	Immediate disable
35	FLT: MT6835 Enc No Communication	0x02	0x0000 0008	0x7300	<p>This fault occurs when, for 3 consecutive MTS cycles of 62.5 μs (3 x 62.5 μs), the CPU reads 0xFFFF,FFFF from the MT6835 feedback device. This is due to a missing connection to the feedback device.</p>	Immediate disable
36	FLT: MT6835 Enc CRC Failed	0x02	0x0000 0010	0x7300	<p>This fault occurs when, for 3 consecutive MTS cycles of 62.5 μs (3 x 62.5 μs), the CPU detects a CRC error of the data received from the MT6835 feedback device.</p>	Immediate disable
37	FLT: EE Emulator Error	0x02	0x0000 0020	0xFF01	<p>This fault occurs if a file erasure fails.</p>	Immediate disable

Fault ID#	Serial String	Fault Word object 2032h (sub-index)	Fault Word Error Mask	Error Code object 603Fh (sub-index 0x00)	Description	TIM Response
39	FLT: Drive Under Voltage	0x02	0x0000 0080	0x3120	The fault occurs if the measured bus voltage (serial command BusVoltageSense) reaches or drops below the undervoltage threshold (serial command UnderVoltageThreshold) for 3 samples.	Immediate controlled stop
42	FLT: Drive Overload	0x02	0x0000 0400	0x2350	This faults occurs if the command to the current controller (serial command lcmd) is saturated by the drive's overload current (serial command DriveOverLoadI), and this fault is enabled (serial command OverloadMode = 0).	Immediate controlled stop
44	FLT: Motor Overload	0x02	0x0000 1000	0x2350	This fault occurs if the command to the current controller (serial command lcmd) is saturated by the motor's overload current (serial command MotorOverLoadI), and this fault is enabled (serial command OverloadMode = 0).	Immediate controlled stop
52	FLT: Speed Phase Advance Design	0x02	0x0010 0000	0xFF01	The speed phase advance feature requires that Speed2 ≥ Speed1 and that Phase2 ≥ Phase1 . If these conditions are not met, and the drive is enabled, this fault will occur. The user must change the values so that conditions are met.	Immediate disable
54	FLT: MT6835 Enc Under Voltage	0x02	0x0040 0000	0x7300	This fault occurs when, for 3 consecutive MTS cycles of 62.5 μs (3 x 62.5 μs), the MT6835 feedback device reports a Weak Under Voltage Warning in its STATUS register. This error is reported by the feedback device itself. This fault cannot be cleared by the Clearfaults command. Try clearing the fault by power cycling the drive. If the fault persists, contact STXI Motion Technical Support.	Immediate disable

Fault ID#	Serial String	Fault Word object 2032h (sub-index)	Fault Word Error Mask	Error Code object 603Fh (sub-index 0x00)	Description	TIM Response
57	FLT: Heatsink Over Temp	0x02	0x0200 0000	0x4110	<p>This fault occurs when the measured heatsink temperature (serial command HeatSinkTemp) exceeds the heatsink temperature threshold (serial command HeatsinkTempThreshold), and the fault is enabled (serial command HeatsinkMode is 0).</p> <p>Note: When the Heatsink Temp Sensor Fault (fault #61) occurs, HeatSinkTemp returns an unrealistic value of 1004 or 1005 to provide information about the Heatsink Temp Sensor Fault. The values 1004 or 1005 also trigger this fault.</p> <p>This fault can be ignored when serial command HeatsinkMode is 1.</p>	Immediate controlled stop
59	FLT: Authorization Key Is Missing	0x02	0x0800 0000	0xFF01	<p>The error occurs if the product did not receive an authorization key during the production process.</p> <p>Contact STXI Motion Technical Support.</p>	Immediate disable

Fault ID#	Serial String	Fault Word object 2032h (sub-index)	Fault Word Error Mask	Error Code object 603Fh (sub-index 0x00)	Description	TIM Response
60	FLT: Motor Brake Fault	0x02	0x1000 0000	0x7110	<p>This fault occurs in the following instances:</p> <ul style="list-style-type: none"> • The actual brake state (engaged or disengaged) does not match the commanded state for a duration of 0.1[s] or more. This fault condition is valid in units without SMM with brake type (serial command BrakeType) 1 or 2. This fault condition is also valid in units with SMM. • Hardware brake fault indication for a duration of 0.1[s] or more, valid for brake type (serial command BrakeType) 0. This fault condition is valid only in units without SMM. <p>Corrective measures: Verify the following parameters according to your setup and provide the values of the parameters to STXI Motion Technical Support:</p> <p>BrakeSupport BrakeType BrakeVoltage BrakeResistance BrakeHoldCurrentFactor BrakeReleaseTime BrakeHoldTime</p> <p>Furthermore, you may want to scope the actual motor brake current (serial command IBrake) together with the enable/disable state (serial command ActiveState, which can also serve as a record trigger parameter) for checking the motor brake behavior.</p>	Immediate disable

Fault ID#	Serial String	Fault Word object 2032h (sub-index)	Fault Word Error Mask	Error Code object 603Fh (sub-index 0x00)	Description	TIM Response
61	FLT: Heatsink Temp Sensor Fault	0x02	0x2000 0000	0xFF01	This fault occurs if communication with the heatsink temperature sensor fails, and this fault is enabled (serial command HeatSinkMode is 0). In this case, the displayed heatsink temperature will exceed 1000°C to provide information about this fault: 1004 indicates I2C bus read failure. 1005 indicates I2C bus timeout. This fault can be ignored when serial command HeatsinkMode is 1.	Immediate controlled stop
62	FLT: STO Not Active Fault	0x02	0x4000 0000	0xFF01	This fault occurs if STO voltage is removed while the drive is enabled.	Immediate disable
64	FLT: STO Channel 1 Diagnostic Fault	0x03	0x0000 0001	0xFF01	This fault occurs if the diagnostics of STO channel 1 detects a failure in this channel; for example, the diagnostic momentarily asserts STO channel 1, but the hardware feedback indicates that STO channel 1 is not asserted. If the diagnostics of both STO channel 1 and STO channel 2 fail, the drive will reset itself. Contact STXI Motion Technical Support.	Immediate controlled stop
65	FLT: STO Channel 2 Diagnostic Fault	0x03	0x0000 0002	0xFF01	This fault occurs if the diagnostics of STO channel 2 detects a failure in this channel; for example, the diagnostic momentarily asserts STO channel 2, but the hardware feedback indicates that STO channel 2 is not asserted. If the diagnostics of both STO channel 1 and STO channel 2 fail, the drive will reset itself. Contact STXI Motion Technical Support.	Immediate controlled stop
66	FLT: BiSS Config Failed	0x03	0x0000 0004	0x7300	This fault occurs if initialization of the BiSS encoder fails.	Immediate disable

Fault ID#	Serial String	Fault Word object 2032h (sub-index)	Fault Word Error Mask	Error Code object 603Fh (sub-index 0x00)	Description	TIM Response
67	FLT: BiSS Communication Fault	0x03	0x0000 0008	0x7300	The fault occurs if there are consecutive communication failures (CRC, watchdog, timeout) with the BiSS encoder.	Immediate disable
68	FLT: BiSS Feedback Alarm	0x03	0x0000 0010	0x7300	This fault occurs if the BiSS encoder sets its alarm bit (encoder temperature sensor) too high.	Immediate disable
69	FLT: BiSS Feedback Warning Bit Set	0x03	0x0000 0020	0x7300	This fault occurs when the BiSS encoder sets its warning bit. All BiSS encoder warning bits are OR'ed together.	Immediate disable
70	FLT: CAN Init Failed	0x03	0x0000 0040	0xFF01	This fault occurs if the BiSS encoder set a warning bit in its telegram.	Immediate disable
72	FLT: Motor Temp Sensor Fault	0x03	0x0000 0100	0xFF01	This fault is relevant for PTC motor temperature sensor (serial command MotorTempSensor equals 1). This fault occurs in the following instances: <ul style="list-style-type: none"> • The motor temperature sensor is not connected. • The measured resistance of the motor temperature sensor is higher than the sensor's maximum resistance according to its datasheet. • The measured resistance of the motor temperature sensor is lower than the sensor's minimum resistance according to its datasheet. 	Immediate controlled stop
73	FLT: Invalid Drive Peak Current	0x03	0x0000 0200	0xFF01	The fault occurs if the drive peak current (serial command DriveIPeak) exceeds 1000 A. Contact STXI Motion Technical Support.	Immediate disable
74	FLT: Invalid Drive Rated Current	0x03	0x0000 0400	0xFF01	The fault occurs if the drive rated current (serial command DriveIRated) exceeds 1000 A. Contact STXI Motion Technical Support.	Immediate disable

Fault ID#	Serial String	Fault Word object 2032h (sub-index)	Fault Word Error Mask	Error Code object 603Fh (sub-index 0x00)	Description	TIM Response
75	FLT: Personality Info Invalid	0x03	0x0000 0800	0xFF01	This fault occurs if either the digital board EEPROM or the power board EEPROM was not completely initialized with proper values during production process. Contact STXI Motion Technical Support.	Immediate disable
76	FLT: CAN Baud Rate Changed	0x03	0x0000 1000	0xFF01	This fault occurs if the CAN baud rate was modified (serial command CanBaudRate) after the CAN module was initialized. This fault cannot be cleared. The fault disappears after Save (serial command SaveParams 1) and power cycle after the new baud rate is applied.	Immediate disable
77	FLT: Unknown Flash Size	0x03	0x0000 2000	0xFF01	This fault occurs if the digital board EEPROM does not contain a valid value for the digital board QSPI flash size. The serial command FlashSize reads that flash-size value out of the EEPROM and the error is raised in case that the flash size was not yet programmed to the EEPROM (value -1 is returned). Contact STXI Motion Technical Support.	Immediate disable
78	FLT: No Remote Enable	0x03	0x0000 4000	0xFF01	This fault occurs if the functionality of one of the digital inputs is assigned to mode 5 (serial command DigInputnAssign), and the input is at low level.	None (special case)
79	FLT: Consumer 1 Heartbeat Fault	0x03	0x0000 8000	0xFF01	CANopen. This fault occurs if heartbeat 1 is defined and no heartbeat is detected within the designated time (heartbeat period).	Immediate controlled stop
80	FLT: Consumer 2 Heartbeat Fault	0x03	0x0001 0000	0xFF01	CANopen. This fault occurs if heartbeat 2 is defined and no heartbeat is detected within the designated time (heartbeat period).	Immediate controlled stop

Fault ID#	Serial String	Fault Word object 2032h (sub-index)	Fault Word Error Mask	Error Code object 603Fh (sub-index 0x00)	Description	TIM Response
81	FLT: Feedback Extrapolations Limit	0x03	0x0002 0000	0xFF01	This fault occurs if two or more consecutive feedback interpolations were performed (feedback interpolation is performed when a communication-based feedback device experiences a communication error, such as timing or CRC.	Immediate disable
82	FLT: EtherCAT PHY Write Fault	0x03	0x0004 0000	0xFF01	This fault occurs when a write command to the PHY's register is executed, and the value that is read from the register is not equal to the value that is written. This fault can be cleared.	Immediate disable
83	FLT: Fieldbus Connection Loss Fault	0x03	0x0008 0000	0x8180	This fault occurs for an EtherCAT drive in the following cases: <ul style="list-style-type: none"> • If the drive is in enabled state and the EtherCAT Slave Stack Code reports a Sync Manager Watchdog error in the EtherCAT state machine register AL Status (ESC register AL Status within ESC address 0x130 shows in bit 4 = 0x10 a fault and register AL Status Code inside ESC address 0x134 shows the value 0x001B = Sync Manager Watchdog). This may occur, for example, if the EtherCAT cable is disconnected during operation. • If the drive is in enabled state, and the EtherCat state machine transitions to the INIT state. (States Pre-Op, Safe-Op, and OP are permissible during operation). This condition is critical because, in the INIT state, the drive no longer receives CoE telegrams from the EtherCAT master. As a result, the drive may continue running without proper control by the master. 	Immediate controlled stop
84	FLT: Encoder Power Failure	0x03	0x0010 0000	0x7300	This fault occurs when the encoder power supply fails.	Immediate disable
85	FLT: PWM driver power supply failure	0x03	0x0020 0000	0xFF01	This fault occurs when the PWM driver power supply fails.	Immediate disable

Fault ID#	Serial String	Fault Word object 2032h (sub-index)	Fault Word Error Mask	Error Code object 603Fh (sub-index 0x00)	Description	TIM Response
89	FLT: Kernel Stack OV	0x03	0x0200 0000	0xFF01	Contact STXI Motion Technical Support.	Immediate disable
90	FLT: BiSS MT OV Load Failed	0x03	0x0400 0000	0x7300	BiSS feedback multiturn overflow feature data could not be loaded.	Immediate disable
91	FLT: BiSS MT OV Offline Move Fault	0x03	0x0800 0000	0x7300	BiSS feedback multiturn overflow feature has detected a large offline move.	Immediate disable
92	FLT: Modulo Configuration Fault	0x03	0x1000 0000	0xFF01	Modulo feature configuration error. Modulo high is smaller than modulo low.	Immediate disable
93	FLT: Numerical PFB Limit Fault	0x03	0x2000 0000	0xFF01	Position feedback variable (64 bits) is near its numerical limit.	Immediate controlled stop
96	FLT: Safety Board Does Not Exist	0x04	0x0000 0001	0xFF01	This fault occurs when a safety board is not mounted on a drive that supports a safety board.	Immediate disable
97	FLT: SSI Encoder No Communication	0x04	0x0000 0002	0x7300	This fault occurs if there is no communication to the MA600 encoder over the SSI bus for two or more consecutive trials.	Immediate disable
98	SSI Encoder Parity Error Fault	0x04	0x0000 0004	0x7300	This fault occurs if there is a parity error when reading the position information from the MA600 encoder over the SSI bus for two or more consecutive trials. This might be due to electronic noise or loose wires in the encoder cable.	Immediate disable
99	FLT: SSI Encoder Config Failed	0x04	0x0000 0008	0x7300	This fault occurs if the internal configuration of the SSI bus to communicate with the MA600 encoder fails.	Immediate disable
101	FLT: RTOS OV Event	0x04	0x0000 0020	0xFF01	This fault occurs if one or more of the RTOS thread stacks is near to overflow.	Immediate disable
103	FLT: Safety Module Fault	0x04	0x0000 0080	0xFF01	This fault occurs if the safety module (if it exists) reports an internal fault and the drive gets enabled. Corrective measures: Try to acknowledge the safety card fault via the error acknowledge bit inside the FSoE data. Set the bit from 0 to 1 and then back to 0.	Immediate disable

Fault ID#	Serial String	Fault Word object 2032h (sub-index)	Fault Word Error Mask	Error Code object 603Fh (sub-index 0x00)	Description	TIM Response
104	FLT: Safety Module Brake Fault	0x04	0x0000 0100	0x7110	This fault occurs if the safety module (if it exists) reports a brake fault.	Immediate disable
105	FLT: STO Diagnostic Internal Fault	0x04	0x0000 0200	0xFF01	This fault occurs if there is no safety module, and there is an internal fault related to the STO diagnostic module, such as: <ul style="list-style-type: none"> • Multiple attempts to configure the STO diagnostic module. • STO diagnostic module configuration is not completed. • STO diagnostic module is not running. This fault cannot be cleared.	Immediate disable
106	FLT: STO Channel Mismatch Fault	0x04	0x0000 0400	0xFF01	If there is no safety module, the user is required to operate both STO channels in the same way and at the same time. This fault occurs if the STO channels are not operated in the same way; that is, there is a mismatch between STO channels. This fault cannot be cleared.	Immediate disable
112	FLT: Wrong FW Flashed to Drive	0x04	0x0001 0000	0xFF01	This fault occurs whenever the user has downloaded firmware to the wrong device (such as TIM firmware to a TIM drive). The wrong firmware can only be detected once the firmware download is completed. In such an instance, the incorrect firmware is immediately erased, and the original firmware remains in the drive. This fault can be cleared at any time and a new download can be initiated.	Immediate controlled stop

Fault ID#	Serial String	Fault Word object 2032h (sub-index)	Fault Word Error Mask	Error Code object 603Fh (sub-index 0x00)	Description	TIM Response
113	FLT: Drive Max Over Voltage	0x04	0x0002 0000	0x3110	<p>This fault occurs when the measured bus voltage (serial command BusVoltageSense) exceeds the following minimum values for 1 ms.</p> <ul style="list-style-type: none"> • 30% above Drive Over Voltage level, where Drive Over Voltage level can be read by the serial command OverVoltageThreshold. • 78 volts <p>The above parameters are hardcoded and cannot be modified by the user.</p>	Immediate disable
114	FLT: Invalid Brake Voltage Supply	0x04	0x0004 0000	0xFF01	<p>This fault is applicable to drives with a safety module, which requires the user to specify (using serial command BrakePowerSupply) to which power supply the brake is connected. The initial value of BrakePowerSupply parameter is -1, which indicates that this parameter was not set. This fault is generated when the user tries to enable the drive while BrakePowerSupply parameter is -1.</p>	Immediate disable

Fault ID#	Serial String	Fault Word object 2032h (sub-index)	Fault Word Error Mask	Error Code object 603Fh (sub-index 0x00)	Description	TIM Response
115	FLT: Motor Brake Over Current	0x04	0x0008 0000	0x7110	<p>This fault occurs when the brake current is 1.5 times greater than the brake peak current, where the brake peak current equals brake voltage (serial command BrakeVoltage), divided by the brake resistance (serial command BrakeResistance), for brake types (serial command BrakeType) 1 or 2.</p> <p>Corrective measures: Verify the following parameters according to your setup and provide the values of the parameters to STXI Motion Technical Support: BrakeSupport BrakeType BrakeVoltage BrakeResistance</p> <p>Furthermore, you may want to scope the actual motor brake current (serial command IBrake) together with the enable/disable state (serial command ActiveState, which can also serve as a trigger parameter) for checking the motor brake behavior.</p>	Immediate disable

TIM Integrated Servo Motor

User Manual