

ZED

Single-Axis Servo Drive

User Manual

ORIGINAL DOCUMENT
Manual Revision 3.2



Revision History

Manual Rev.	Date	Notes
Rev.3.2	27 Nov. 2024	Updated Electrical and Fusing specifications. Updated Standards Certifications; all ZED models have TUV, UL and CUL certifications.
Rev.3.1	4 Nov. 2024	Standards Certification (TUV) for model SD01-015
Rev.3.0	21 Dec. 2023	Product name changed from servSD to ZED. Updated rating specifications in Ordering Info (Table 2-2) and in Electrical Specifications (Table 6-1). Updated figures showing model SD01-015.
Rev.2.4a	14 Aug. 2023	Released. No content changes.
Rev.2.4	25 July 2023	Add section I2T Current Protection. Added over-current protection in Safety and Protection specifications table. Updated product label examples. Added notes for 75°C copper conductors in section System Wiring.
Rev.2.3	18 July 2023	Added information in section System Wiring.
Rev.2.2	10 July 2023	Updated IPT protection algorithm. Updated product labels. Updated fuse information. Updated wiring torque information.
Rev.2.1	31 Jan. 2023	Added new images of SD01-015. Updated ordering information.
Rev.2.0	20 Dec. 2022	Added SD01-015 model (top panel interfaces), and updated manual accordingly. Chapter 6 Electrical Installation – fully revised. Added fusing specifications, updated specifications and electrical interfaces. Miscellaneous updates, corrections, and new formatting.
Rev.1.2	9 June 2022	Updated Standards: TUV certification. Corrected Motor Brake Control diagram (Disable via haltMotion (no controlled ramp down)).
Rev.1.1	31 Mar. 2022	Initial release.

Copyright Notice

© 2024 STXI Motion Ltd.

All rights reserved. No part of this work may be reproduced or transmitted in any form or by any means without prior written permission of STXI Motion Ltd.

Disclaimer

This product documentation was accurate and reliable at the time of its release. STXI Motion Ltd. reserves the right to change the specifications of the product described in this manual without notice at any time.

Trademarks

ZED is a trademark of STXI Motion Ltd.

CANopen and CiA are registered trademarks of the CAN in Automation User's Group

Windows is a registered trademark of Microsoft Corporation

Contact Information

www.stxim.com

contact@stxim.com

CANopen Vendor-ID

Vendor-ID **0513** has been registered to STXI Motion Ltd.
(specified in object 1018h sub-index 01).

Contents

1	About This Manual	
1.1	Manual Overview	6
1.2	Safety Symbols	6
1.3	Installation Overview	7
2	Drive Description	
2.1	Product Features	8
2.1.1	ZED Key Features	8
2.1.2	I2T Current Protection	8
2.2	Product Label	9
2.3	Ordering Info	10
3	Safety	
3.1	Safety Guidelines	11
3.2	Safety and Protection Specifications	12
3.3	Intended Use	13
4	Handling and Storage	
4.1	Transporting	14
4.2	Packing/Unpacking	14
4.3	Environmental Specifications	14
5	Mechanical Installation	
5.1	Installation Safety	15
5.2	Mechanical Specifications	15
5.3	Heatsink	17
5.4	Mounting Multiple ZED Units	17
6	Electrical Installation	
6.1	Installation Safety	18
6.2	Electrical Specifications	19
6.3	Fusing	19
6.4	System Wiring	22
6.4.1	Grounding	24
6.4.2	Emergency Bus Voltage Disconnection	25
6.4.3	Regenerated Power Absorption	26
6.4.4	Inrush Current Limit	27
6.5	Cables and Connectors	28
6.5.1	Mating Connectors	28
6.5.2	Cables	29
6.6	Electrical Interfaces	29
7	Commissioning	
7.1	Motor Controller Software Installation	41
7.2	Communication	41
7.2.1	Communication Specifications	41
7.2.2	CAN Communication	41
7.2.3	Serial Communication	42
7.3	Drive Addressing	44
7.4	Drive Configuration	45
7.5	Power Up	46

8	Motor Brake Control	
8.1	Motor Brake Control Serial Commands and CAN Objects	52
8.2	Debugging Motor Brake Control Serial Commands	53
9	Operation	
9.1	Operational Safety.....	54
10	Maintenance	
10.1	Maintenance Safety	55
10.2	Troubleshooting.....	55
10.2.1	Status LED.....	55
10.2.2	Built-in Protection	56
10.2.3	Faults	56
10.2.4	Network Communication Issues.....	57
11	Functional Safety (STO)	

1 About This Manual

1.1 Manual Overview

This documentation describes the ZED servo drive.

It provides the information required for installation, configuration, and basic operation of the ZED.





This documentation is intended for persons who are qualified to assemble, commission, and maintain the equipment described herein.

Before you install the ZED, review the instructions in this manual. Pay particular attention to all safety instructions and warnings. Failure to follow the safety instructions may result in personal injury or equipment damage.

1.2 Safety Symbols

The following safety symbols are used on the drive and in this manual.

Table 1-1. Safety Symbols

Symbol	Meaning	Description
	Dangerous voltage	Indicates a hazardous situation, which, if not avoided, will result in death or serious injury.
	Caution	Indicates a hazardous situation, which, if not avoided, could result in injury or equipment damage.
	Protective earth; protective ground	Identifies a terminal intended for connection to an external conductor for protection against electric shock in case of a fault; also indicates the terminal of a protective earth (ground) electrode.
	Caution, hot surface	Indicates the marked item can be hot, and should not be touched without taking care.

1.3 Installation Overview

To install the ZED, perform the following steps.

1. Mechanical installation:
Mount the ZED.
2. Electrical installation:
Make all wiring and cable connections, as required by your application:
 - I/Os (C1 connector)
 - Motor feedback (C2 connector)
 - CANopen fieldbus devices (C3 or C4 connector)
CANopen network: set 120 Ω termination resistor on a CAN dongle cable
 - Safe torque off (STO) (P4 connector)
 - Motor U-V-W (P3 connector)
 - Motor brake (P1 connector)
 - Logic power (P1 connector)
 - Motor power (P2 connector)
3. Connect the ZED to the host computer.
4. Power up the ZED and the host computer.
5. Install software on the host computer for setup and tuning

2 Drive Description

2.1 Product Features

The ZED by STXI Motion is a compact, low voltage open type servo drive, with an output current of up to 30A. Its small footprint enables space-saving and near-motor mounting. It fits easily within the space constraints of enclosures such as electronics assemblies, medical devices, and AGVs/AMRs.

Supporting common motor feedback types and STO functional safety, the ZED meets the full range of resolution and safe operation requirements from basic to highly dynamic applications.

The ZED is intended for use in pollution degree 2 and OVC II environments. The ZED is not intended for direct connection to mains. It provides current limiting control and overload protection (without thermal memory retention or speed sensitivity).

2.1.1 ZED Key Features

Key features of the ZED include:

- High power density in a small footprint
- Ready-to-connect. No need for pin soldering or cable adaptors.
- Simple commissioning GUI with comprehensive parameterization options
- Supports numerous types of motor feedback: SSI, incremental with Hall sensors, BiSS
- STO functional safety (SIL 3/PL e)
- Near-motor mounting for tight space constraints applications
- SD01-015 models have all interfaces on top panel, to simplify integration in systems with space limitations

2.1.2 I2T Current Protection

The ZED uses the I2T current protection mechanism to protect the drive and motor from overheating due to excessive current.

The I2T parameters are set separately set for the drive and for the motor. This is performed in the Motor Controller GUI by setting **continuous current limit** parameter and **peak current limit** parameters. The lesser value of the motor and servo drive should be set to protect both the motor and drive.

By default, the continuous current limit is limited to the maximum current supported by the ZED; for example, 20 A_{RMS} for ZED model SD01-030, and 12A_{RMS} for ZED model SD01-015.

The I2T protection algorithm uses the lower value of the above parameters. When the current exceeds the defined current limit, the drive limits the output current; that is, 20 A_{RMS} for ZED model SD01-030, and 12A_{RMS} for ZED model SD01-015).

2.2 Product Label

The product label is attached to the side of the drive.

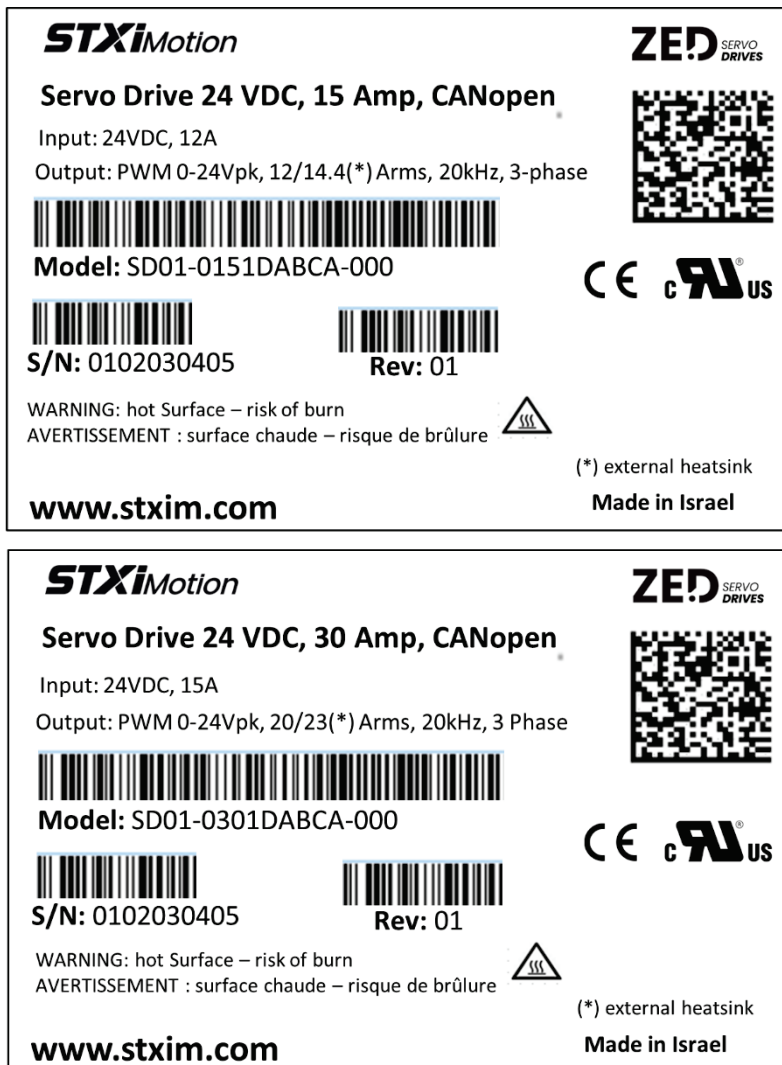

Figure 2-1 Product label examples

The following table details the information provided in the product label.

Table 2-1. Product Label Codes

Item	Description
Name	Product description
Model	Part number (refer to Ordering Information)
S/N	Product serial number.
Rev	Part number revision. 2 digits.

2.3 Ordering Info

The following table shows the ordering options that comprise the various model numbers of the drives in the ZED product line. To enquire about custom options, contact STXI Motion.

Table 2-2. Product ordering options

	SD01	-	030	1D	AB	CA	-	000
ZED Single-Axis Servo Drive								
Rating – Cont. Current, Peak Current								
015	12/14.4 (*) 40 Arms @ 24 VDC							
025	18/20 (*) 63 Arms @ 48 VDC							
030	20/23 (*) 70 Arms @ 24 VDC							
xxx	Custom							
Power								
1D	Bus 20-60 VDC, Logic 24 VDC optional							
xx	Custom							
Feedback								
AB	Incremental AB quad, index, Halls, 12-bit RS422							
AS	Absolute SSI							
xx	Custom							
Communication								
CA	CANopen							
xx	Custom							
Options								
000	Standard							
xxx	Custom							

(*) requires external heatsink

3 Safety

3.1 Safety Guidelines

Only qualified personnel may perform installation, operation, service, and maintenance procedures. These persons must have sufficient technical training and knowledge to foresee and recognize potential hazards that may occur when using the product, modifying settings, and operating the mechanical, electrical, and electronic components of the entire machine system.

All persons working on and with the product must be fully familiar with all applicable standards, directives, and accident prevention regulations when performing such work.

Before installing the ZED, be sure to review the safety instructions in the product documentation. Failure to follow the safety instructions may result in personal injury or equipment damage.



The ZED drive utilizes hazardous voltages. It must be properly grounded.



During operation the surfaces of the drive can become very hot. The heat sink can reach a temperature of 90°C and the plastic enclosure can reach 80°C.

3.2 Safety and Protection Specifications

Table 3-1. Safety and Protection Specifications

Feature	Specification
Protective Functions	<p>Over-current protection, Over- and under-voltage protection, Drive and motor over-temperature protection, Over-speed protection, Power stage fault, Position command error, Hall error, Encoder/Hall sync error Acceleration/deceleration violation, DSP clock fail, Internal sensor fail, Motor stall, STO1 STO2 fail, SSI fail.</p> <p>Note: The drive does not provide electronic motor overload protection with thermal memory retention or with speed sensitivity.</p> <p>Overload protection is provided by the I2T protection algorithm. It protects the drive and motor from overheating due to excessive current.</p> <p>The ZED max (peak current, peak time) and rated currents are predefined, and cannot be modified.</p> <p>Motor max (peak current, peak time) and rated currents are user-definable parameters.</p> <p>The max and rated values of the protection algorithm are determined by the lesser value of the motor and the ZED values.</p> <p>When the actual current exceeds the calculated value for a duration longer than the nominal max peak-time, the current is reduced to the nominal rated current.</p>
Standards Certification (TUV)	<p>EN 61508. Functional safety</p> <p>IEC 61800-5-2 SIL 3. Adjustable speed electrical power drive systems – functional safety</p> <p>ISO 13849-1, Cat. 3, PL e. Safety of machinery</p>
UL Standard	UL 61800-5-1
CUL Standard	CAN/CSA C22.2 No. 274

3.3 Intended Use

The ZED servo drive is intended for use as a component within a machine system.

The machine builder and integrator must ensure the protection of both personnel and the complete machine system.

The machine builder and/or integrator must perform a risk assessment in view of using the ZED drive in the intended application. Based on the results, the appropriate safety measures must be implemented.

The ZED drive must be used in compliance with all applicable safety regulations and directives, and all technical specifications and requirements.



The machine builder and the machine owner are responsible for the safety of the machine operators.



The machine owner and the machine operator are responsible for ensuring personnel cannot enter the hazard zone while the machine is energized unless adequate functional safety mechanisms are in place.

4 Handling and Storage

4.1 Transporting

Transport the drive in its original packaging materials.

Avoid transporting the drive in conditions which may cause strong vibrations of the drive, or impact with other objects.

4.2 Packing/Unpacking

The package contains the ZED drive only.

Upon receipt, open the package and remove all packing materials.

Check to ensure there is no visible damage to the ZED drive. If damage is detected, notify the carrier immediately.

After unpacking, check the part number label on the product. Make sure it matches the product you ordered, and that the voltage meets your specific requirements.

Save the original box and packing materials in case you need to pack and return the product to the manufacturer.

4.3 Environmental Specifications

Table 4-1. Environmental Specifications

Feature	Specifications	
Environment	Ambient temperature: Operation: 0 – 45°C Operation at reduced power: 45 – 70°C Storage: 0 – 70°C Heat sink max. temperature: 100°C Max. surrounding air temperature for open type drives: 45°C	
	Humidity: 10 – 90%	
	Altitude: If in accordance with specified clearances, per IEC 61800-5-1, the servo drive is rated for use at altitudes up to 2000 m	
	Vibration: IEC60068-2-6	
	Operating Conditions	Protection class: IP20 Pollution degree: 2 as per IEC 60664-1 Do not use where the following are present: corrosive gases, flammable gases, water, oil, chemicals, dust (including iron dust and salts)

5 Mechanical Installation

5.1 Installation Safety

Mount the ZED on a grounded conductive metal panel. The panel must be sufficiently rigid.

For mounting dimensions, refer to the section Mechanical Installation.

5.2 Mechanical Specifications

Table 5-1. Mechanical Specifications

Feature		SD01-015	SD01-025 SD01-030
Mounting		brick	book, brick
Weight	kg	0.3	0.3
Dimensions (LxWxH)	mm	70 x 106 x 34.75	70 x 106 x 40

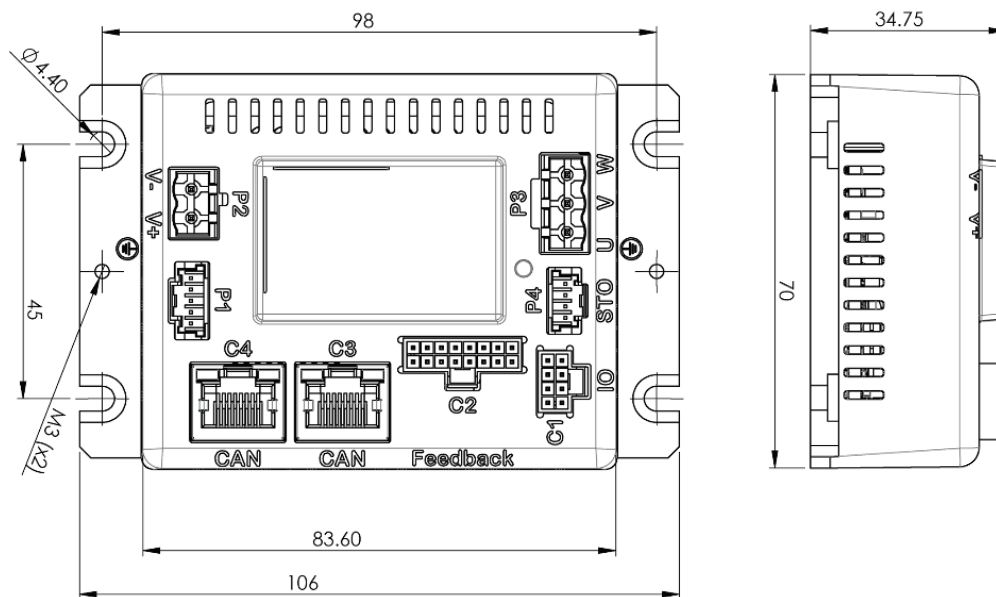

Figure 5-1 SD01-015 dimensions

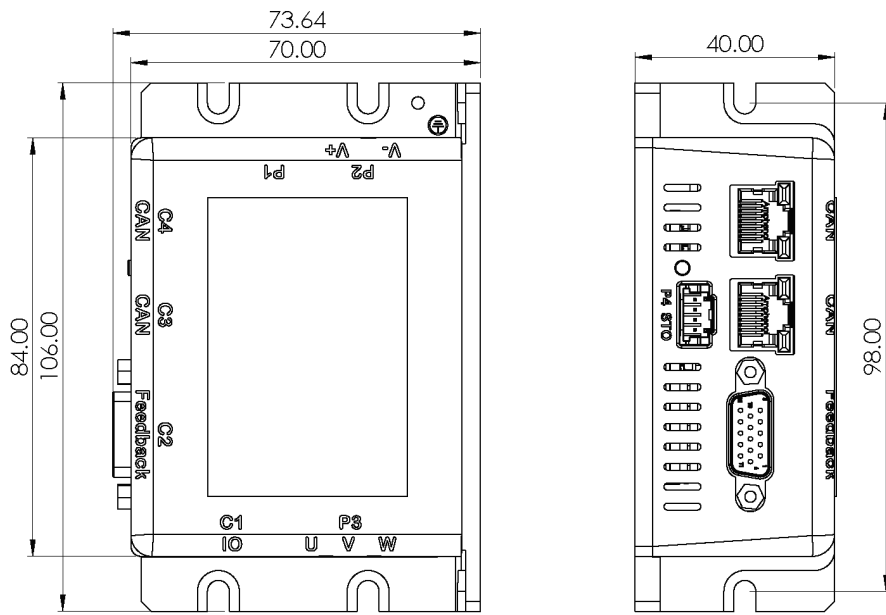

Figure 5-2 SD01-025.| SD01-030 dimensions

5.3 Heatsink

For additional heat dissipation, a heat sink can be mounted onto the ZED.

To mount the heatsink, use M4 screws designed for fastening aluminum.

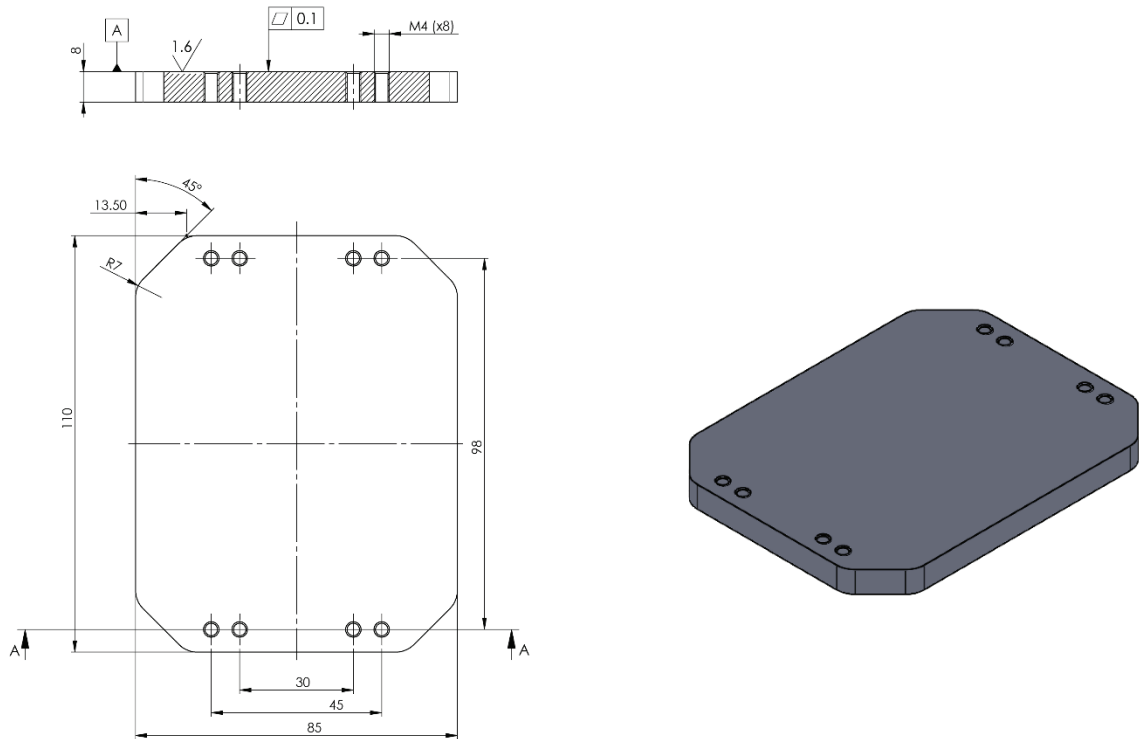

Figure 5-3 External heatsink example

5.4 Mounting Multiple ZED Units

When multiple ZED units are mounted within a cabinet or enclosure, the recommended minimum spacing between units is 10 mm. The recommended minimum top and bottom clearance is 50 mm.

6 Electrical Installation

6.1 Installation Safety

Note | Incorrect handling of the ZED may cause personal injury and/or damage to equipment.



When connecting the ZED to other control equipment, be sure to follow two basic guidelines to prevent damage to the drive:

- The ZED must be grounded to the chassis of the machine.
- Any motion controller, PLC or PC that is connected to the ZED must be grounded to the same earth ground as the ZED.

- Before installing or commissioning the ZED, review all relevant product documentation.
- Perform the installation in strict compliance with product specifications and installation instructions.
- All system components must be connected to ground. Electrical safety is provided through a low-resistance earth ground connection. (Protective Class 1 according standard EN/IEC 618005-1.) The motor should be connected to protective earth by an independent earthing conductor rated not less than the motor wire.
- For wiring, use copper wires. Conductor's cross-section can be derived from IEC 60204. As an alternative for AWG cross-section, use NEC table 310-16, 75°C column.
- As part of the machine design, the machine builder must generate a hazard analysis for the machine and take appropriate measures to ensure that unforeseen movements cannot cause personal injury and/or damage to equipment.
- The drive meets IP20 (per IEC 60529), and type 1 (per UL 50); therefore, the machine builder must select a suitable enclosure. The enclosure must meet at least IP54 (per IEC 60529), and at least type 2 (per UL 50), and be composed of metal or a material with rating flammability of 5 VA, and not have any openings in the bottom.
- Wiring of a yellow color with or without one or more green stripes must not be used, except for protective bonding. Minimum size of the bonding conductor is 14 AWG.
- Altitude: If in accordance with specified clearances, per IEC 61800-5-1, the ZED is rated for use at altitudes up to 2000 meter above sea level.
- A fault exclusion must be carried out for the STO input wiring according to EN 61800-5-2 Table D.1 and D.3 / EN ISO 13849-2, Table D.5.
- Users must perform a manual test of the STO function at least once every three months. The diagnostic test entails removing the STO supply voltage and verifying that the drive is indeed in the STO Fault state, and that motion is inhibited.

6.2 Electrical Specifications

Table 6-1. Electrical Specifications

Feature		SD01-015	SD01-025	SD01-030
Voltage Input	VDC	24 ±10%	48 ±10%	24 ±10%
External Input Power Fuse	A	15	30	30
Power	W	275	710	420
Continuous Current	Arms	12	18	20
Continuous Current with heat sink	Arms	14.4	20	23
Peak Current	Arms	40	70	63
Logic Power Input	V	24	24	24
External Input Logic Fuse	A	1	1	1
P2 Cable – Power	AWG	10	8	8
P3 Cable – Motor phases	AWG	15	12	12

6.3 Fusing

Circuit protection must be provided in accordance with the national electrical code and any additional local codes. Therefore fusing is required, as defined below (or equivalent).

Table 6-2. Fusing Specifications

	External Input Power Fuse * SD01-015	External Input Power Fuse SD01-025/-030	External Input Logic Fuse
Manufacturer	Cooper Bussmann	LITTELFUSE	Cooper Bussmann
Type/model	ABC-15-R Size: 6.35 x 31.75 mm	0326030.MXP Size: 6.35 x 31.75 mm	ABC-1-R Size: 6.35 x 31.75 mm
Technical data	125 VDC, 15A, 10kA	125VDC, 30A, 600A	125 VDC, 1A, 10kA
Standard (edition/year)	UL 248-14 CSA Certification: Class No: 1422-01 & 1422-30, File 53787	UL 248-14	UL 248-14 CSA Certification: Class No: 1422-01 & 1422-30, File 53787
Mark(s) of conformity	UL (E19180)	UL (E10480)	UL (E19180)

* **Note:** Suitable for use on a circuit capable of delivering not more than 62.5A available current and 24V maximum, when protected by external listed fuse, model ABC-15-R by Cooper Bussmann, rated 125VDC/15A, as stated in the manual.

Table 6-3. Feedback and Control Specifications

Feature	Specifications
Operation modes	<ul style="list-style-type: none"> ▪ CANopen: profile and synchronous velocity (OPMODE 9, 3). ▪ For debugging, all operation modes can be operated via serial communication.
Display	1 x 3-color LED
Encoder	12-bit incremental, RS422 communication, differential quadrature, index pulse, single-ended Halls
Motor temperature	PTC temperature sensor
Software Tools	Motor Controller software, Windows-based Connection settings, Drive info, Power info, I/O configuration, Motion settings and tuning, Fault history/display
Rotary Units	Position: counts Velocity: counts/s Acc/Dec: counts/s ²

Table 6-4. Inputs/Outputs Specifications

Feature	SD01-015	SD01-025 SD01-030
Digital inputs	3	4
Signal	Configurable opto-isolated. User defined compatibility with sinking or sourcing input.	Configurable opto-isolated. User defined compatibility with sinking or sourcing input.
Functions	Homing, limit switch,	Homing, limit switch, remote enable, start motion
Voltage High Level Input	30 V	30 V
Min. High Level Input	11 V	11 V
Max. Low Level Input	5 V	5 V
Input Resistance	4.99 kΩ	4.99 kΩ
Max. Input Frequency	1 kHz	1 kHz
Isolation Voltage	2500 Vrms	2500 Vrms
Max. Input Current	According to max. voltage level, input current is not limited, drive limits the input current	According to max. voltage level, input current is not limited, drive limits the input current
Propagation Delay Time	1 ms	1 ms

Feature	SD01-015	SD01-025 SD01-030
Digital outputs	1	2
Signal	Configurable open collector. User defined compatibility with opto-isolated sinking output or sourcing output.	Configurable open collector. User defined compatibility with opto-isolated sinking output or sourcing output.
Functions		Motor speed set, Current, Motor speed set clear, Motion completed, In position, Zero speed, Software position limit switch, Active, Selectable.
Max Logic High	27.8V @ 30V	27.8V @ 30V
Min Logic low	2.2V @ 100 mA	2.2V @ 100 mA
Max. Current	150 mA	150 mA
Min. Load Resistance	60 Ω	60 Ω
Output Voltage	0.25 V	0.25 V
Min. Propagation Delay Time	1 ms (may be longer if load current is lower)	1 ms (may be longer if load current is lower)
Analog inputs	1	–
Voltage input	0–10 VDC	

6.4 System Wiring

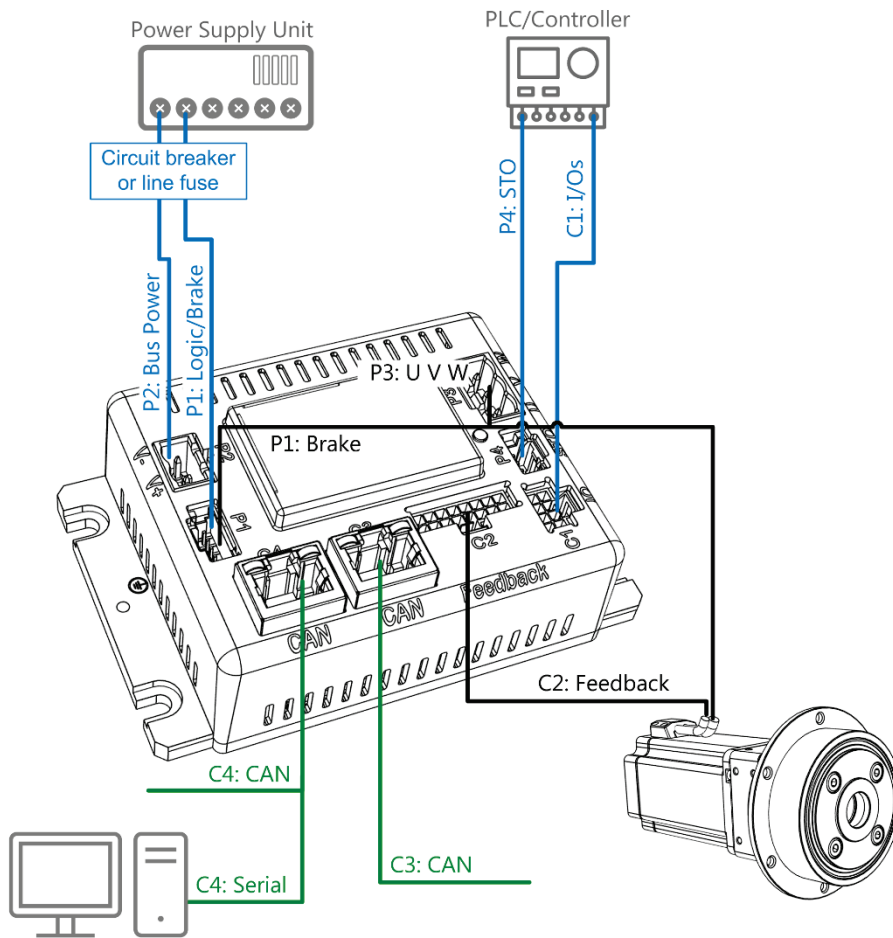

Figure 6-1 System Wiring - SD01-015



Use 75°C copper conductors only.

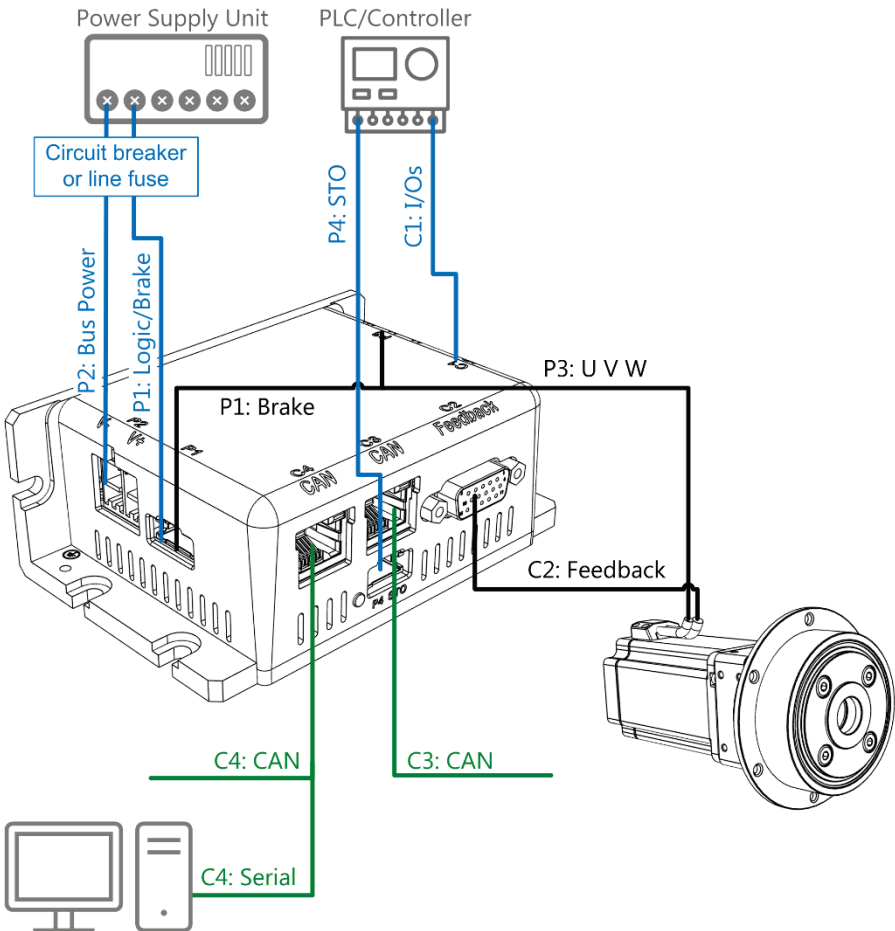

Figure 6-2 System Wiring - SD01-025 | SD01-030



Use 75°C copper conductors only.

6.4.1 Grounding



When connecting the ZED to other control equipment, be sure to follow two basic guidelines to prevent damage to the drive:

- The ZED must be grounded to the chassis of the machine.
- Any motion controller, PLC, or PC that is connected to the ZED must be grounded to the same earth ground as the ZED.

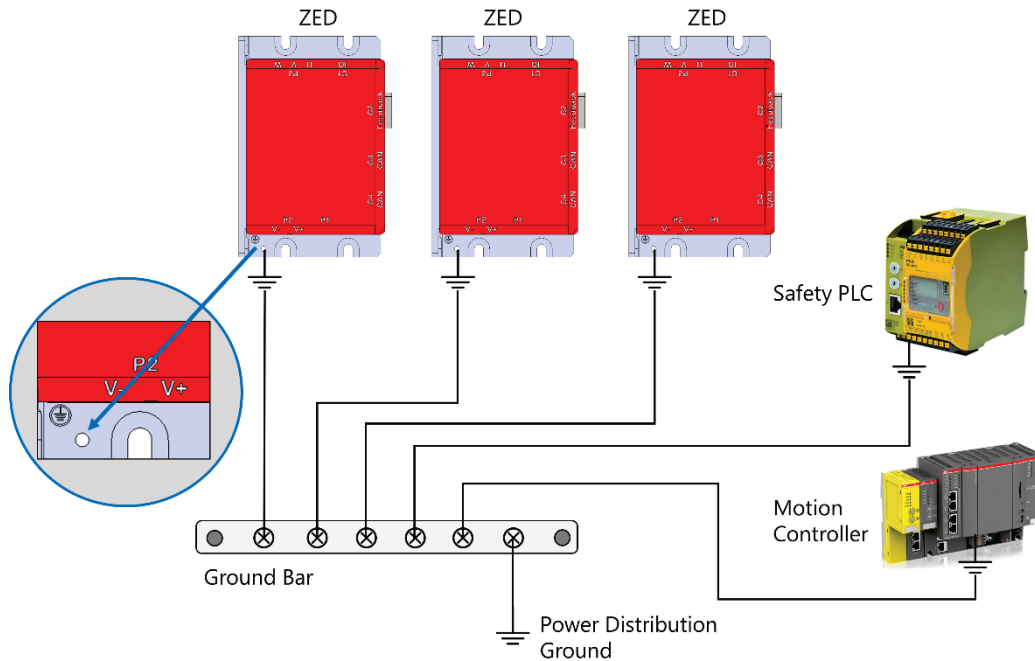

Figure 6-3 System Grounding

Power Ground and Control Ground Connections

The power ground and control ground connections in the ZED drive are not galvanically separated. Therefore, some care is needed to ensure proper operation.

Power Input Modes

Single power input mode. The ZED contains a special circuit that detects the voltage source. If there is no **logic input voltage**, then the **input bus voltage** is connected internally to the control voltage. Be sure to keep maximum voltage input less than 50V.

Regular power input mode. The input power sources are separate. **Input bus voltage** is connected directly to the motor bridge transistor and the **logic input voltage** is connected to the logic component of the ZED.

It is the user's responsibility to prevent overvoltage power input. In addition, an internal 70 VDC transient voltage suppressor (TVS) protects the ZED from overvoltage and surges.

Isolated and Non-isolated Ground Sources

The ZED drive requires two sources of ground that are galvanically isolated from each other.

- Power ground. Supplies the motor bridge transistors – high current.
- Control ground. Supplies the logic component of the drive.

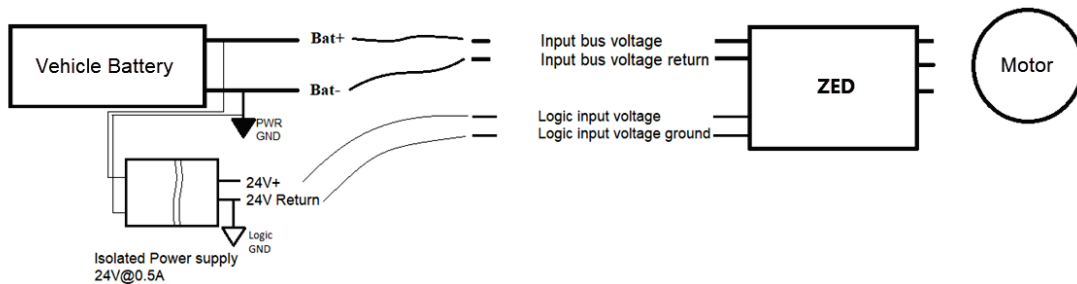

Figure 6-4 Power and ground connection isolated power supplies

In certain cases, when the power supplies for the ZED are not galvanically separated, the grounding scheme must prevent a voltage gap between the power ground and the control ground that could potentially damage the ZED.

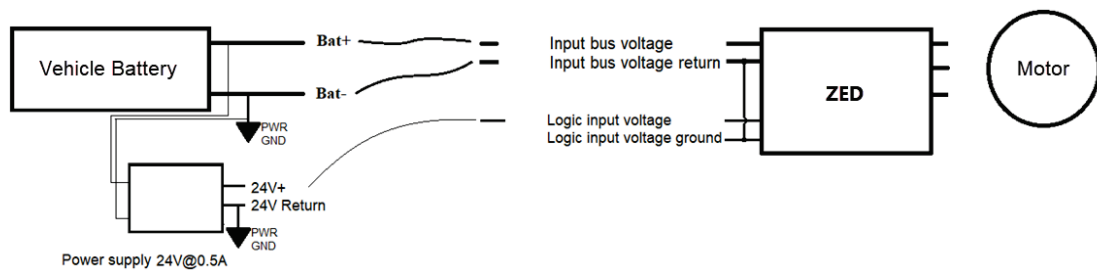

Figure 6-5 Power and ground connection non-isolated power supplies

6.4.2 Emergency Bus Voltage Disconnection

The ZED is supply with a TUV-approved STO mechanism. There is no need for a bus voltage disconnection.

However, if such an emergency stop is required, it is recommended to use an external regen resistor, or a switch with a discharge diode.

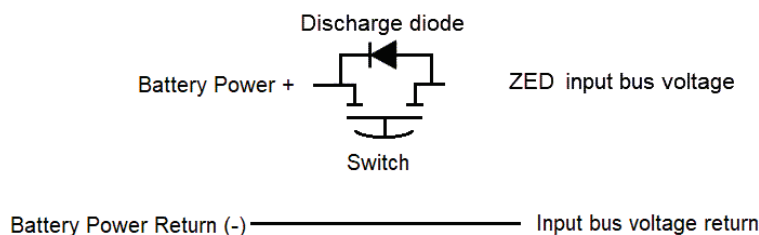

Figure 6-6 Diode (Vishay T70HF10)

6.4.3 Regenerated Power Absorption

To absorb the power generated by the motor during deceleration or braking, it is necessary to store and dissipate the power driving the mechanical system.

Motor bridge during deceleration

During deceleration, the transistors bridge has two states:

1. Shorts the current via the MOSFET transistors back to the motor. The generated current creates a magnetic field opposite to the direction of the vehicle.

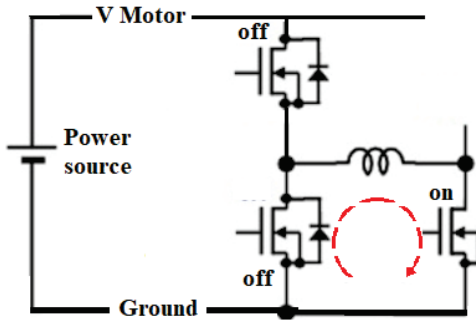

Figure 6-7

2. Disconnection of the transistors. The current flows via the MOSFET transistor diodes, from ground through the motor coil to the V Motor rail.

In this state the current must be absorbed by the system to prevent overvoltage on the V motor rail that could damage the bridge transistors.

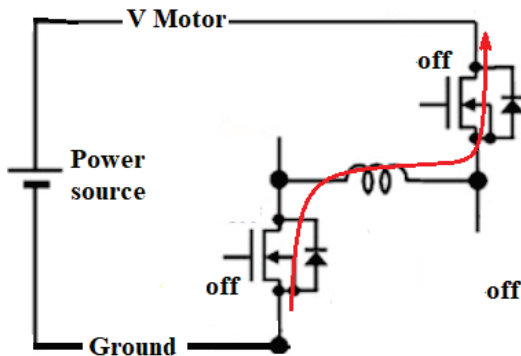

Figure 6-8

Energy absorption during deceleration

Energy absorption is performed through a series of actions.

1. **Power return to battery.** This is the primary element of the absorption of the generated current by the motor and therefore saves energy and increases the total power efficacy of the vehicle. If the battery is fully charged and unable to absorb the current, then the second power absorption stage is implemented.

2. **Input bus voltage capacitors.** These capacitors are connected to two charge reservoirs:
- Internal drive ripple capacitors, typically 220–750 μF and voltage range that can reach 40–50V above the normal V motor rail voltage.
 - A secondary external capacitor, typically 10–100 mF and voltage range that can reach 40–50V above the normal V motor rail voltage.

The total energy that can be absorbed by the two charge reservoirs is: $\frac{V^2 * C(F)}{2}$

Example: For an application running at 48V, the capacitors can be charged up to 75V.

The ZED internal capacitors are 600 $\mu\text{F}/80\text{V}$.

The internal ZED absorption capacitor's capability is:

$$\frac{V^2 * C(F)}{2} = \frac{1}{2} * 27^2 * 600 * 10^{-6} = 0.218_{(\text{joule})}$$

If using an external capacitor of 10 mF/100V (such as EPCOS TDK B41560A9109M), the external absorption capacitor's capability is:

$$\frac{V^2 * C(F)}{2} = \frac{1}{2} * 27^2 * 10 * 10^{-3} = 3.645_{(\text{joule})}$$

3. **Power resistor.** These resistors operate when the V motor bus voltage exceeds normal bus voltage (35–40V).

Example: Absorption of 3000 joule during 10 seconds of deceleration.

If the bus voltage is 48V, the current to be absorbed is 6.25A for 10 seconds.

The external capacitor is 10,000 $\mu\text{F}/100\text{V}$. (Vishay RH250)

The regen resistor is 10 Ω 250W.

6.4.4 Inrush Current Limit

In many motors drives and controllers, it is necessary to limit the current when power is switched on. The high value of the V motor bus capacitors creates an inrush current which can reach several hundred amperes.

To prevent inrush issues during power on, it is recommended to use two relays, as show in the following figure.

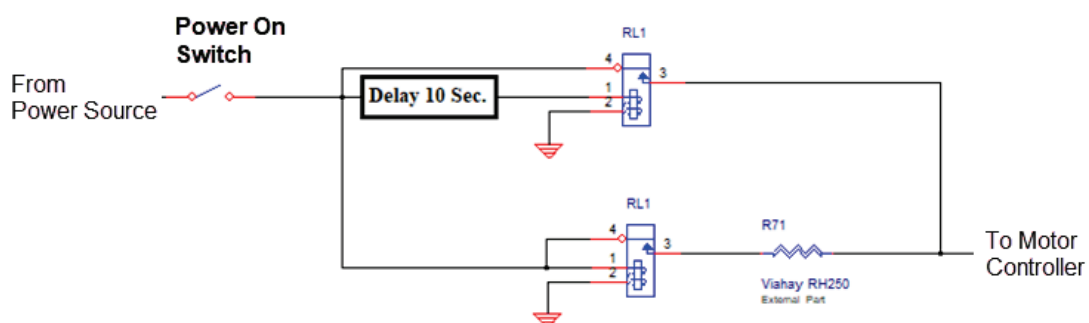

Figure 6-9

6.5 Cables and Connectors



Use copper conductors only.

6.5.1 Mating Connectors

Mating connectors are not supplied with the drive and must be ordered separately.

SD01-015

Individual mating connectors are available for the SD01-015. For ordering details, refer to the connector tables in the section *Electrical Interfaces*.

SD01-025 | SD01-030

A mating connector kit is available for the SD01-025 and SD01-030.

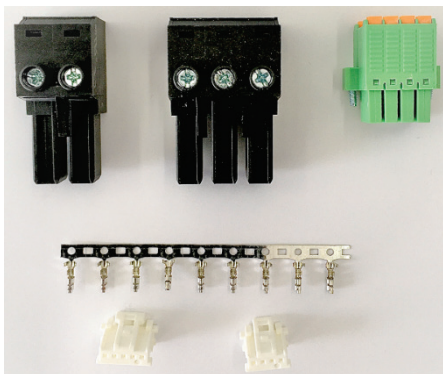

Figure 6-10 Mating Connectors Kit - SD01-025 | SD01-030

Description	STXI Motion Part Number
SD01-025 SD01-030 Mating connectors kit (ports P1-P2-P3-P4-C1)	MK01-P1P2P3P4C1000

6.5.2 Cables



Figure 6-11 Commissioning Cable

Cables are not supplied with the drive and must be ordered separately.

Description	STXI Motion Part Number
Commissioning cable for ZED (port C4)	CBL-ASKRJ45DSUB9

6.6 Electrical Interfaces

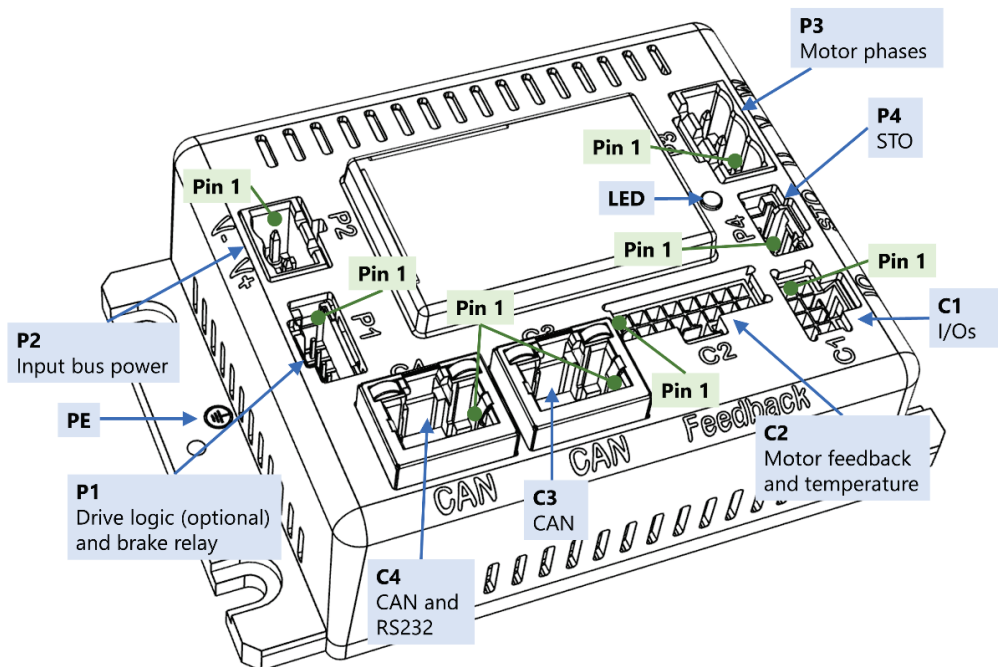

Figure 6-12 System Interfaces - SD01-015

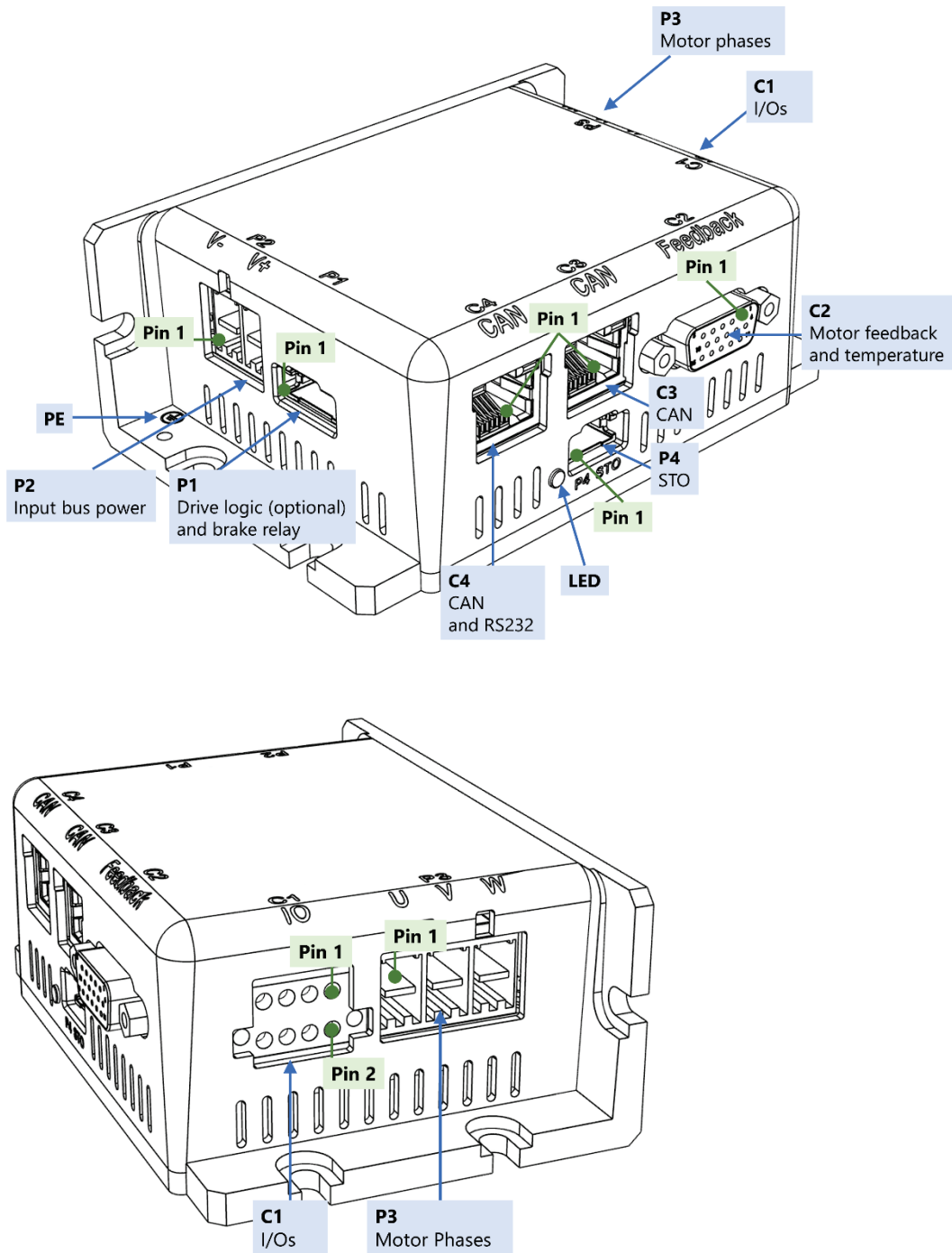

Figure 6-13 System Interfaces - SD01-025 | SD01-030

P1 – Drive Logic and Brake Power

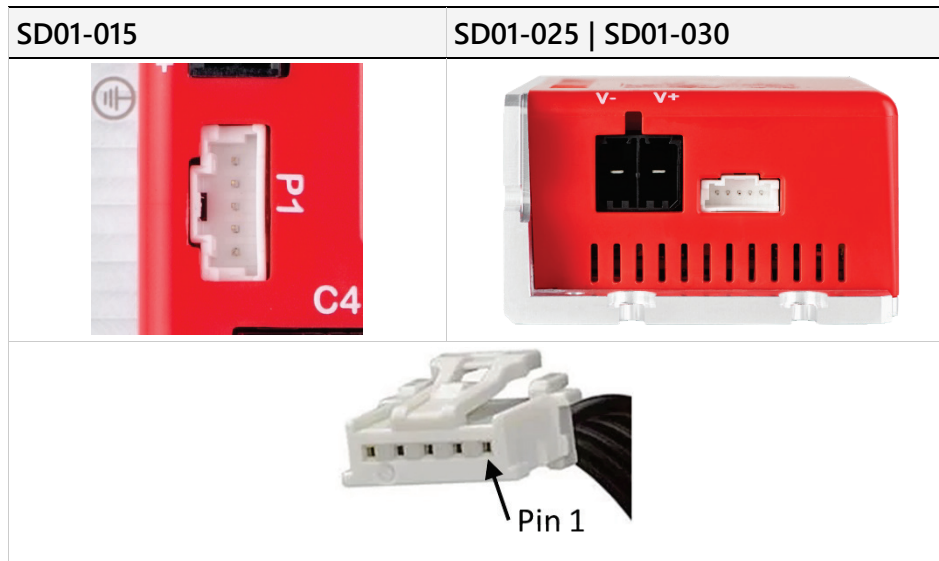

Figure 6-14 Drive Logic and Brake Power

P1 Pinout

Pin #	Name	Signal Description
1	Aux_PWR	Logic input voltage 24 VDC (optional)
2	Aux_RTN	Logic input voltage ground (optional)
3	Brake_PWR	User power supply for motor brake 24 VDC 0.5A
4	Brake_RTN	User power supply for motor brake ground / Motor brake wire 1
5	Brake wire	Motor brake wire 2

P1 Mating connector

Connector receptacle	Molex 55935-0510
STXI Motion PN	CON-MOLOTS5CIP1 – Cable Assembly
Manufacturer	Molex
Manufacturer PN	15136-0501 – Cable Assembly
Connector pitch	2 mm
Wiring	AWG 22

Optional

	<p>Molex: 51382-0500 Plug</p> <p>Molex: 56134-9001 Crimp terminal (5 pcs)</p>
---	---

P2 – Input Bus Voltage



Figure 6-15 Input Bus Voltage

P2 Pinout

Pin #	Label	Signal Description
1	V-	Input bus voltage return
2	V+	Input bus voltage (20-60V)

P2 Mating connector – SD01-015

Connector receptacle	Molex 39531-0002
STXI Motion PN	CON-MOLVER2CIP2
Manufacturer	Molex
Manufacturer PN	39530-0002 or 39533-2002
Connector pitch	5.08 mm
Wiring	10 AWG
Torque (clamping screws)	5 lb-in (0.57 Nm)

P2 Mating connector – SD01-025 | SD01-030

STXI Motion PN	CON-DEG7622P2AH
Manufacturer	Degson Electronics
Manufacturer PN	5EDGKH-7.62-02P
Connector pitch	7.62 mm
Wiring	8 AWG
Torque (clamping screws)	7 lb-in (0.8 Nm)

P3 – Motor Phases

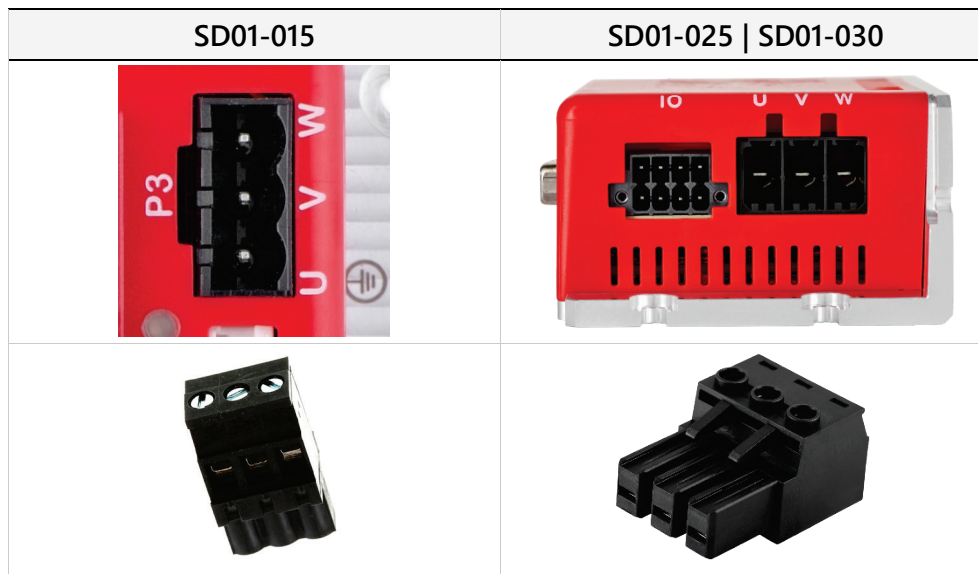

Figure 6-16 Motor Phases

P3 Pinout

Pin #	Label	Signal Description
1	U	Motor phase U
2	V	Motor phase V
3	W	Motor phase W

P3 Mating connector – SD01-015

Connector receptacle	Molex 39531-1003
STXI Motion PN	CON-MOLVER3CIP3
Manufacturer	Molex
Manufacturer PN	39533-2003
Connector pitch	5.08 mm
Wiring	15 AWG
Torque (clamping screws)	5 lb-in (0.57 Nm)

P3 Mating connector – SD01-025 | SD01-030

Connector receptacle	Degson Electronics 5EDGRHC-7.62-03P
STXI Motion PN	CON-DEG7623P2AH
Manufacturer	Degson Electronics
Manufacturer PN	5EDGKH-7.62-03P
Connector pitch	7.62 mm
Wiring	12 AWG
Torque (clamping screws)	7 lb-in (0.8 Nm)

P4 – STO

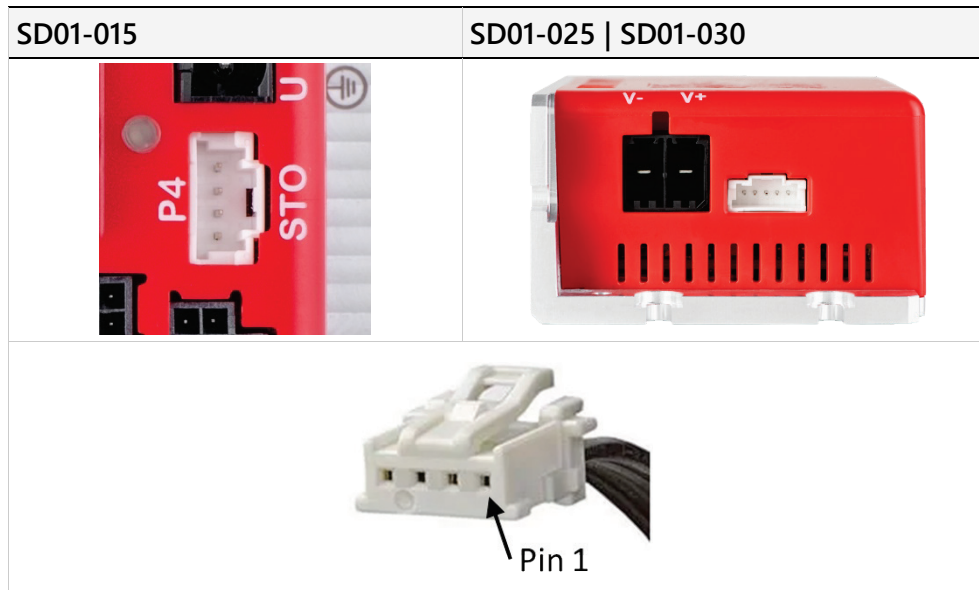

Figure 6-17 STO

P4 Pinout

Pin #	Signal Description
1	STO1
2	STO status to external device (e.g., PLC)
3	STO2
4	Ground

Note: Both STO1 and STO2 must be enabled

P4 Mating connector

Connector receptacle	Molex 55932-0410
STXI Motion PN	CON-MOLOTS4CIP4 – Cable Assembly
Manufacturer	Molex
Manufacturer PN	15136-0501 – Cable Assembly
Connector pitch	2 mm
Wiring	AWG 22

Optional

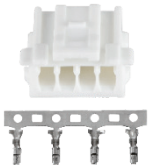
<p>Molex</p> 	<p>Molex: 51382-0400 Plug Molex: 56134-9001 Crimp terminal (4 pcs)</p>
--	--

C1 – Inputs/Outputs

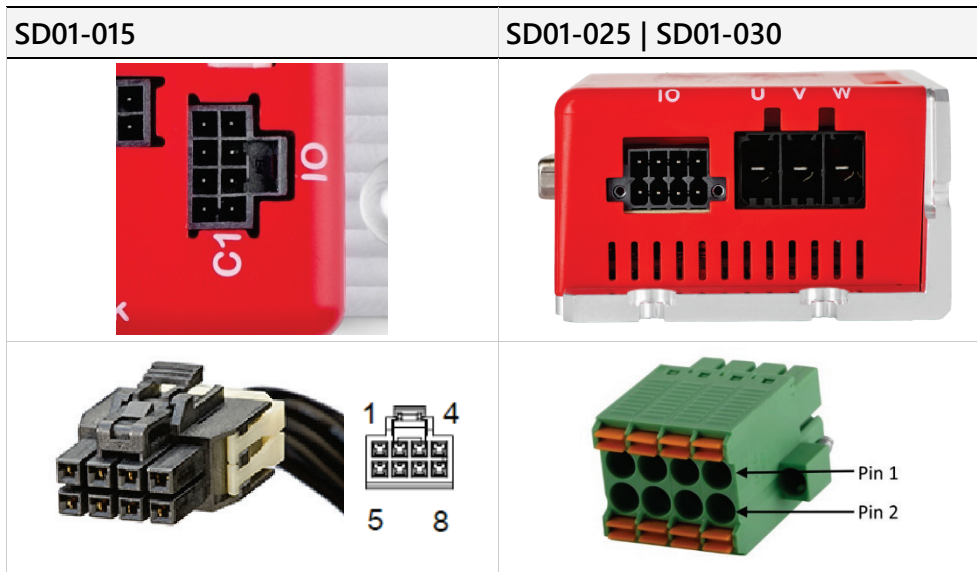

Figure 6-18 Inputs/Outputs

Note | Input functionality is not yet implemented in the ZED.

C1 Pinout

	SD01-015	SD01-025 SD01-030
Pin #	Signal Description	Signal Description
1	Digital input 1	Digital input 1
2	Digital input 2	Digital input 2
3	Digital input 3	Digital input 3
4	Analog input -	Digital input 4
5	Common input	Common input
6	Digital output 1	Digital output 1
7	Analog input +	Digital output 2
8	Common output	Common output

C1 Mating connector – SD01-015

Connector receptacle	Molex 105310-1108
STXI Motion PN	CON-MOLOTS8CIC1 – Cable assembly
Manufacturer	Molex
Manufacturer PN	45130-0810 – Cable assembly
Connector pitch	2.50 mm
Wiring	20 AWG

Optional

Molex: 105308-1208 Plug
Molex 105300-2100 Crimp terminals

C1 Mating connector – SD01-025 | SD01-030

Connector receptacle	Degson Electronics 15EDGRHCM-THR-3.5-08P-1300AH
STXI Motion PN	PLU-DEGMHN14E00
Manufacturer	Degson Electronics
Manufacturer PN	15EDGKNHM-3.5-08P-14-00A(H)
Connector pitch	3.5 mm
Wiring	28–16 AWG

C2 – Motor Feedback and Temperature

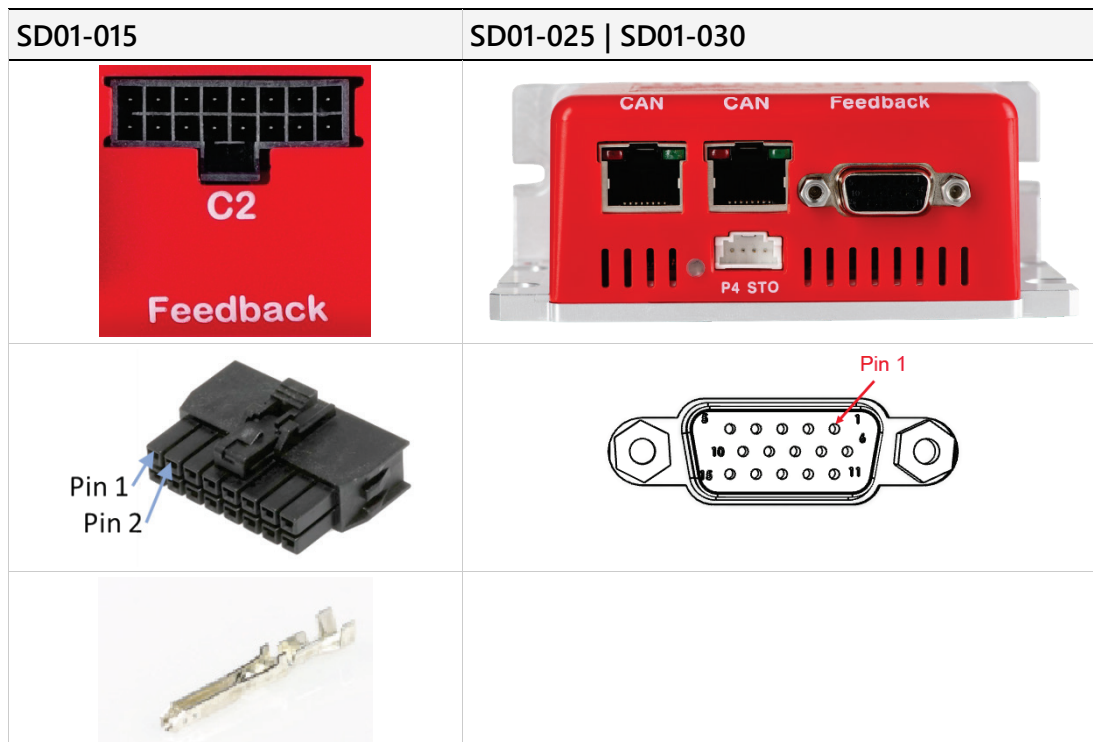

Figure 6-19 Motor Feedback and Temperature

C2 Pinout – SD01-015

Pin #	Signal Description Incremental Encoder
1	Encoder channel A+
2	Encoder channel B+
3	Index Z+
4	5V
5	
6	Hall U+
7	Hall W+
8	Temp PTC1
9	Encoder channel A-
10	Encoder channel B-
11	Index Z-
12	Hall GND
13	
14	Hall V+
15	Temp PTC2
16	Shield

C2 Mating connector – SD01-015

Connector receptacle	Molex 105310-1116
STXI Motion PN	Plug - CON-MOLDR16CIC2 Crimp Pin - CRI-MOLFEM254UM
Manufacturer	Molex
Manufacturer PN	Plug - 105308-1216 Crimp Pin - 105300-2100
Connector pitch	2.5 mm
Wiring	22–20 AWG

C2 Pinout – SD01-025 | SD01-030

Pin #	Signal Description Incremental Encoder	Signal Description SSI Encoder
1	Encoder channel A+	Encoder channel A+
2	Encoder channel B-	Encoder channel B-
3	Hall 1 (U+)	Hall 1 (U+)
4	VCC_Out_5V	VCC_Out_5V
5	Motor temperature sensor -	Motor temperature sensor -
6	Encoder channel A-	Encoder channel A-
7	Index+	BiSS clock +
8	Hall 2 (V+)	Hall 2 (V+)
9	Ground	Ground
10		BiSS data+
11	Encoder channel B+	Encoder channel B+
12	Index-	BiSS clock -
13	Hall 3 (W+)	Hall 3 (W+)
14	Motor temperature sensor +	Motor temperature sensor +
15		BiSS data+

C2 Mating connector – SD01-025 | SD01-030

Connector receptacle	NorComp 200-015-213L537
STXI Motion PN	Use any standard D-sub 15-pin, 3-row connector

C3 and C4 – CAN

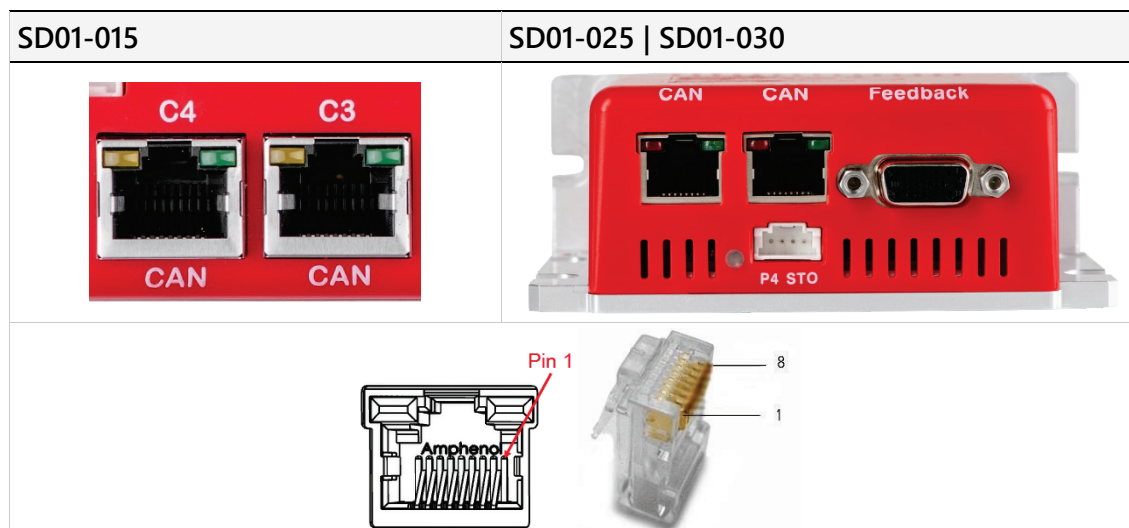

Figure 6-20 CAN C3 and CAN C4

Notes

- **C3 and C4:** A 120 Ω termination resistor is required at both ends of the CAN bus network between CAN_L and CAN_H. This is the responsibility of the user. Wiring requires Cat 5e cable.
- **C4:** Can be used for connection to PC using USB to RS232 adapter cable.

C3 and C4 Pinout

CAN Interface C3		CAN Interfaces C4	
Pin #	Signal Description	Pin #	Signal Description
1	CAN high	1	CAN high
2	CAN low	2	CAN low
3	CAN ground	3	CAN ground
4	–	4	RS232 receive
5	–	5	RS232 ground
6	–	6	RS232 transmit
7	–	7	<i>not connected</i>
8	–	8	<i>for manufacturer use only</i>

C3/C4 Mating connector

Connector receptacle	SD01-015: NorComp 200-015-213L537 SD01-025 SD01-030 : Amphenol RJHSE5387
STXI Motion PN	Use any standard RJ45 connector

Ground

Interface	Item
PE	M3 screw

7 Commissioning

7.1 Motor Controller Software Installation

1. Download the Motor Controller software installation file from the STXI Motion website or contact Technical Support.
2. Install the Motor Controller software on the host computer.
3. When installation is complete, start Motor Controller software from the Windows Start menu or the shortcut on your desktop.

7.2 Communication

7.2.1 Communication Specifications

Table 7-1. Communication Specifications

Feature	Specifications
CANopen	CAN isolated Baud rate 10 kbps – 1 Mbps CAN ID 1 – 126 (Default 127) software setting Communication interface conforms to the following standards: <ul style="list-style-type: none"> ▪ CiA 301: CANopen Application Layer and Communication Profile ▪ IEC 61800-7-1: Interface Definition ▪ IEC 61800-7-201: Profile Type 1 ▪ IEC 61800-7-301: Mapping of Profile Type 1

7.2.2 CAN Communication

Note A serial RS232-USB, or a USB-CAN adapter, is required for commissioning the ZED servo drive. Once the drive is configured, you can then connect it to a PLC or controller over an CANopen network.

Kvaser Leaf USB-CAN Adapter

The Kvaser Leaf USB-CAN interface is used to connect the ZED to the host computer to enable communication with software, such as Kvaser CanKing.



Figure 7-1 Kvaser USB-CAN adapter

1. Before attaching Kvaser Leaf adapter to the host computer, install the Kvaser driver.
 - Go the Kvaser website, and download the driver.
 - Install the driver according to the on-screen instructions.
2. Connect the Kvaser Leaf cable to the USB port on the computer.
 - The Found New Hardware Wizard will detect and complete the driver installation.
 - Confirm hardware installation by opening the Control Panel > Kvaser Hardware. Make sure Kvaser Virtual CAN driver appears in the Devices tab.
3. Make sure the green light (PWR) on the Kvaser cable is lit.
4. Connect the D9 male connector on the Kvaser cable to the female D9 connector on the RJ45 cable.

7.2.3 Serial Communication

USB to RS232 Adapter

A standard serial USB to RS232 adapter, shown in the following figure, is used to connect the ZED to the host computer to enable communication with Motor Controller software.



Figure 7-2 USB to RS232 adapter cable

1. Before attaching the USB to RS232 adapter to the host computer, install the necessary driver.
2. Connect the USB to RS232 adapter to the USB port on the computer.
The Found New Hardware Wizard will detect and complete the driver installation.
3. Connect the D9 male connector on the USB to RS232 cable to the female D9 connector on the RJ45 communication cable.
4. Connect the RJ45 communication cable to the C4 CAN connector on the drive.



Figure 7-3 RJ45 Communication cable

5. Open the Motor Controller software.
6. From the Communication menu, select your COM port.
Press **Connect** to enable communication with the drive.

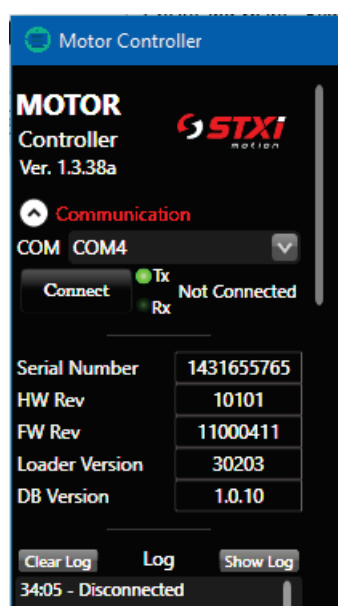

Figure 7-4

7.3 Drive Addressing

By default, the drive's address is CAN-ID:127. This address can be changed easily using the Motor Controller software.

1. In the Drive Parameters window, open the **Device** tab.

The **CAN ID** field displays the current node ID of the drive.

CAN ID: change the number to 127.

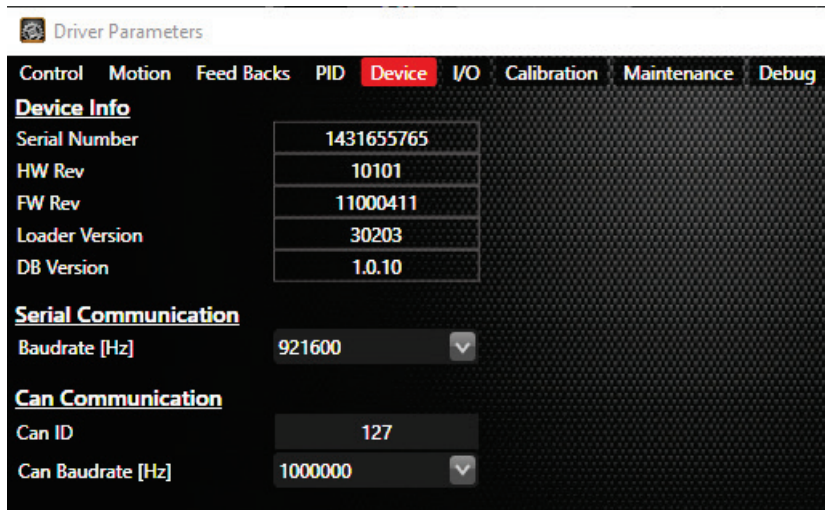

Figure 7-5

2. In the Drive Parameters window, open the **Maintenance** tab.

Save Parameters to File: press **Save**.

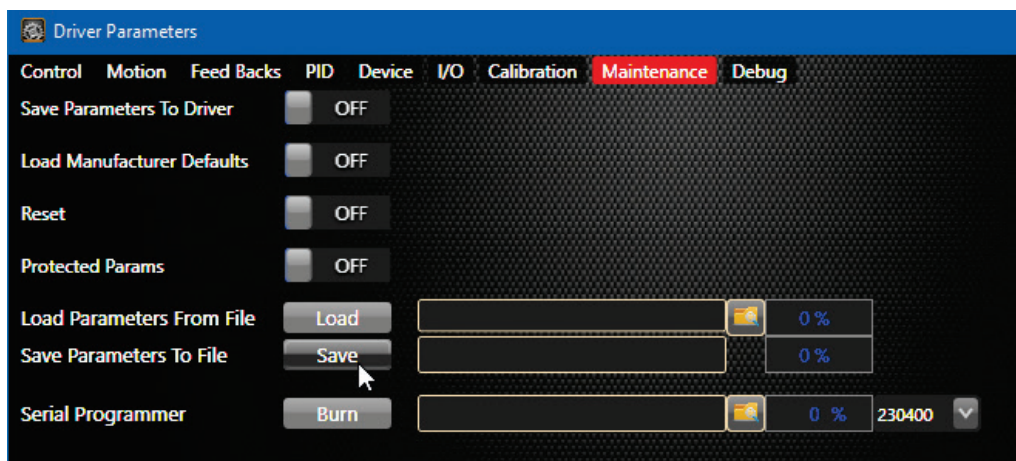

Figure 7-6

3. Reboot the drive. The new CAN ID takes effect after restarting the drive.

7.4 Drive Configuration

1. In the Motor Controller software, select the motor setup **Wizard** from the navigation menu.

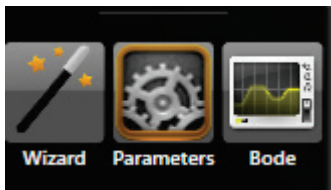

Figure 7-7

2. Set the parameters for your particular motor/encoder.

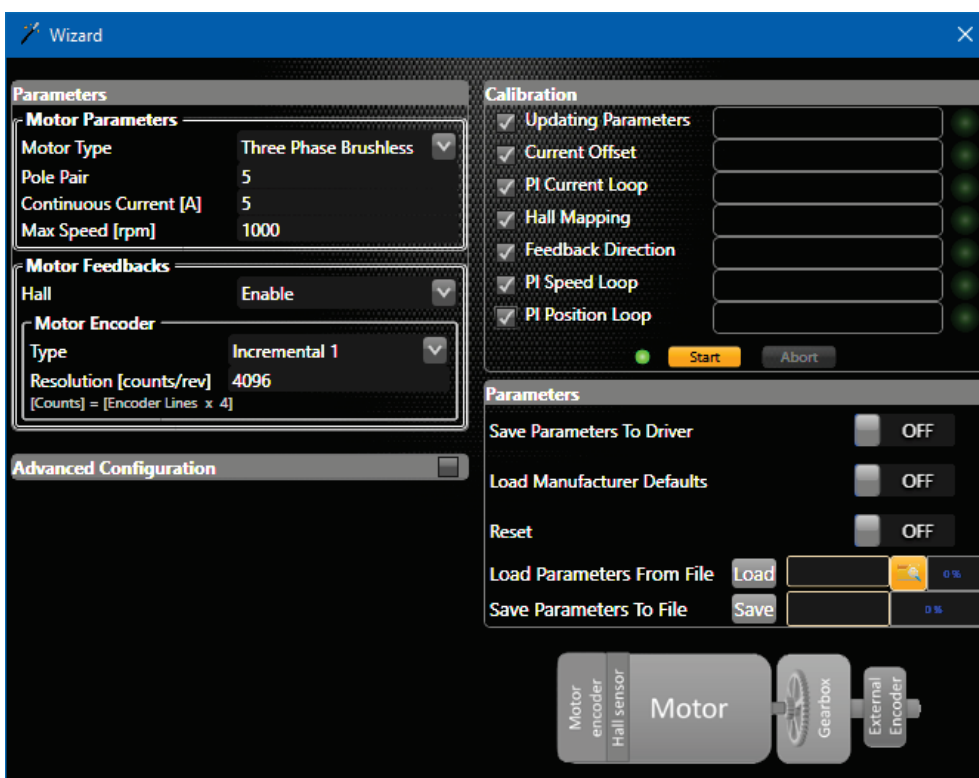

Figure 7-8

3. Calibration: press **Start**.
4. When Calibration is completed, save parameters to drive
5. To modify a parameter, open the Parameter window and change the parameter setting. Be sure to save the parameter to the drive.

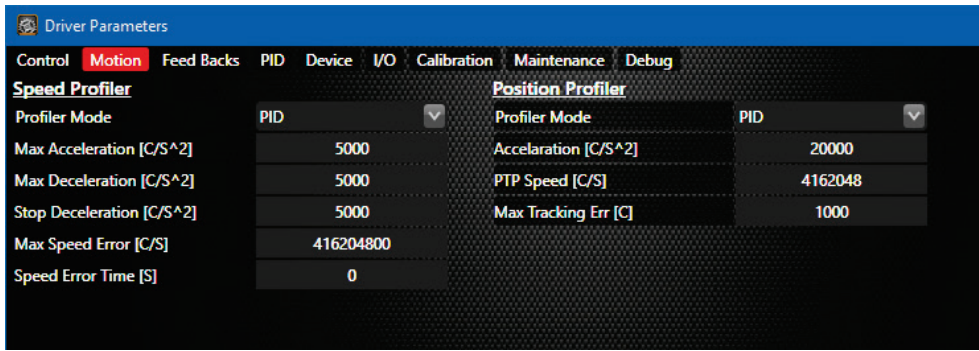

Figure 7-9

7.5 Power Up

After completing the hardware connections and software installations, turn on power to the ZED.

Note If logic and DC bus supplies are separate, it is recommended that logic be turned on before DC bus.

8 Motor Brake Control

The following flow charts describe the processes of enabling and disabling the motor brake.

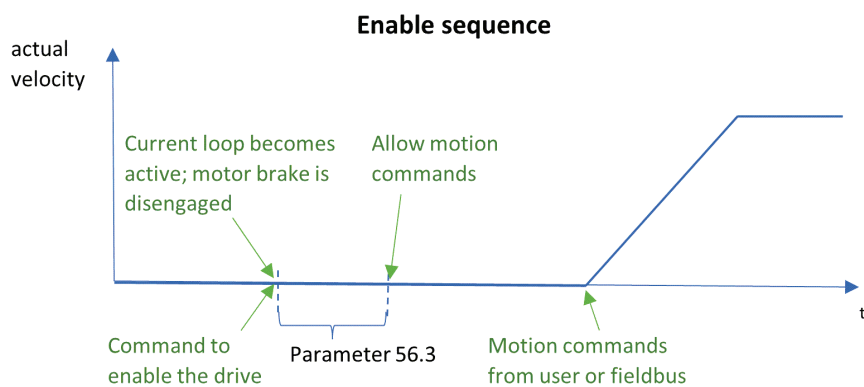
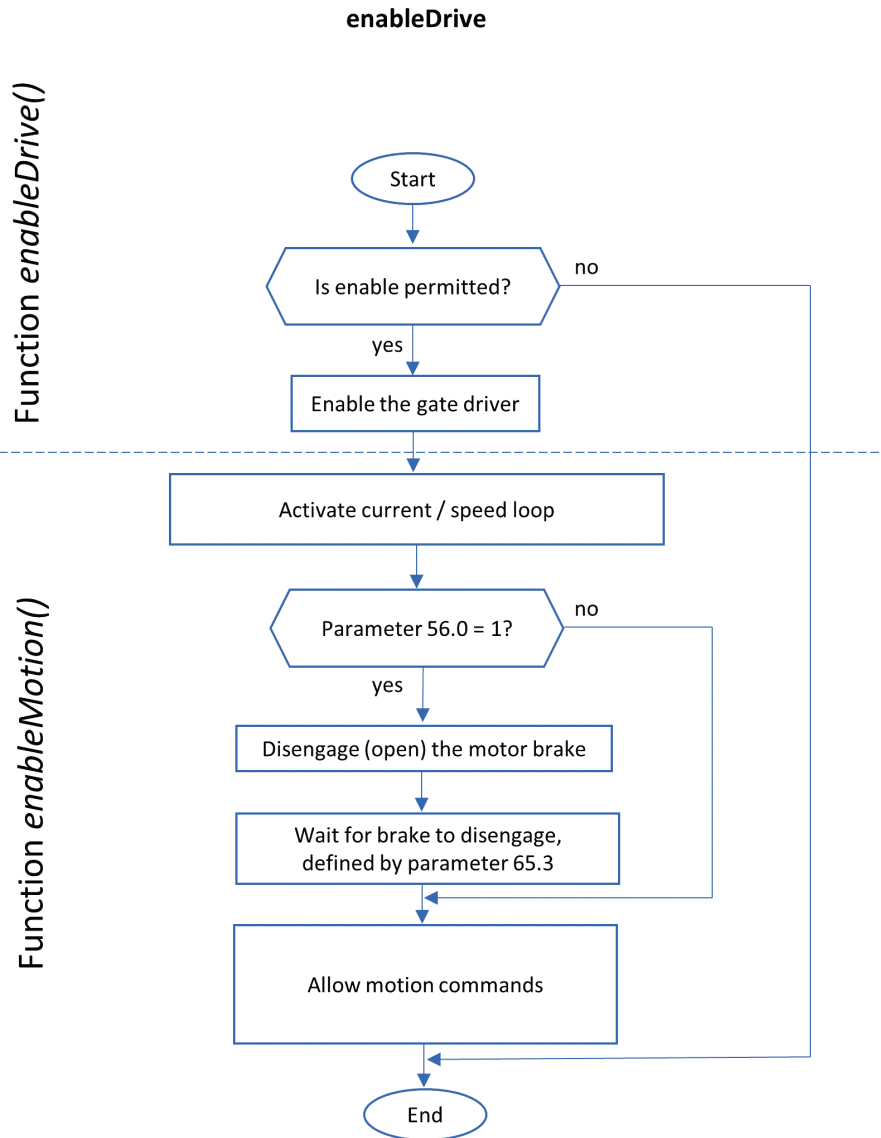

haltMotion (uncontrolled ramp-down process)

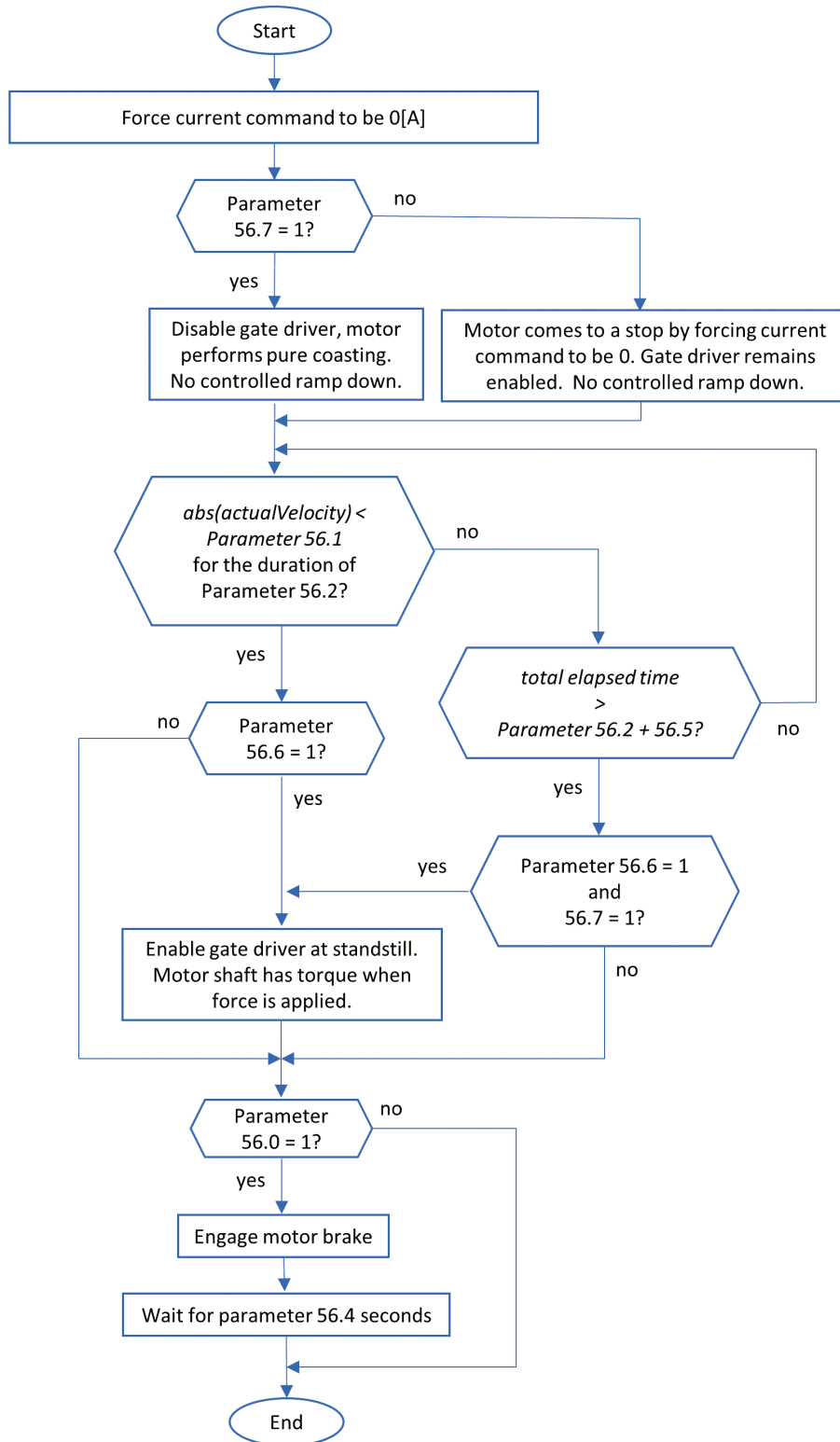

Disable via *haltMotion* (no controlled ramp down)

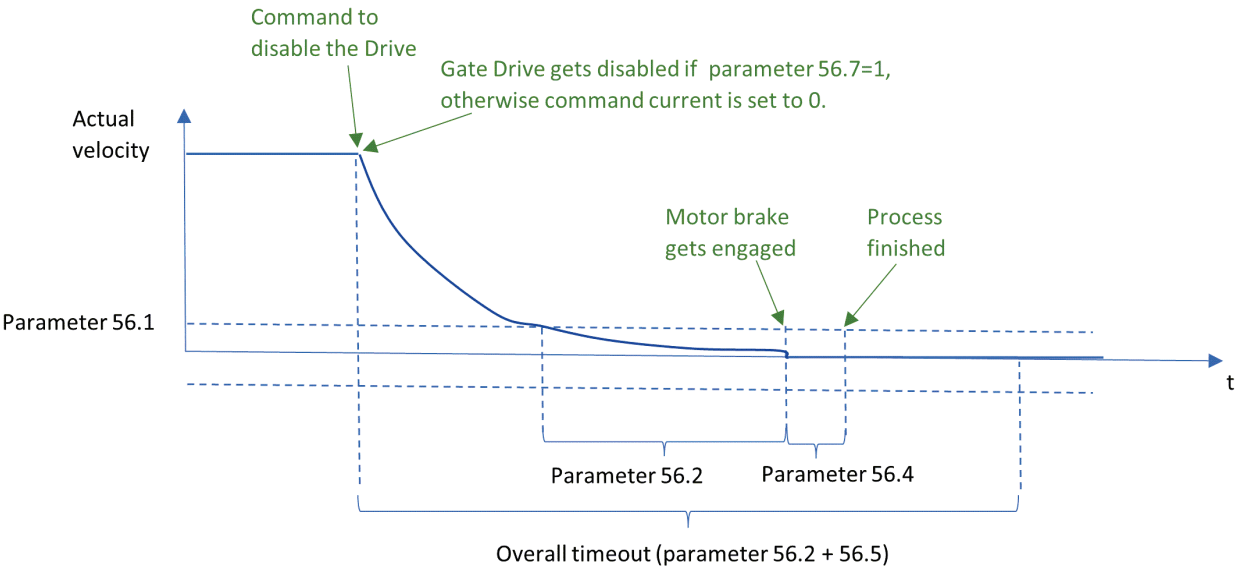

stopMotion (controlled ramp-down process)

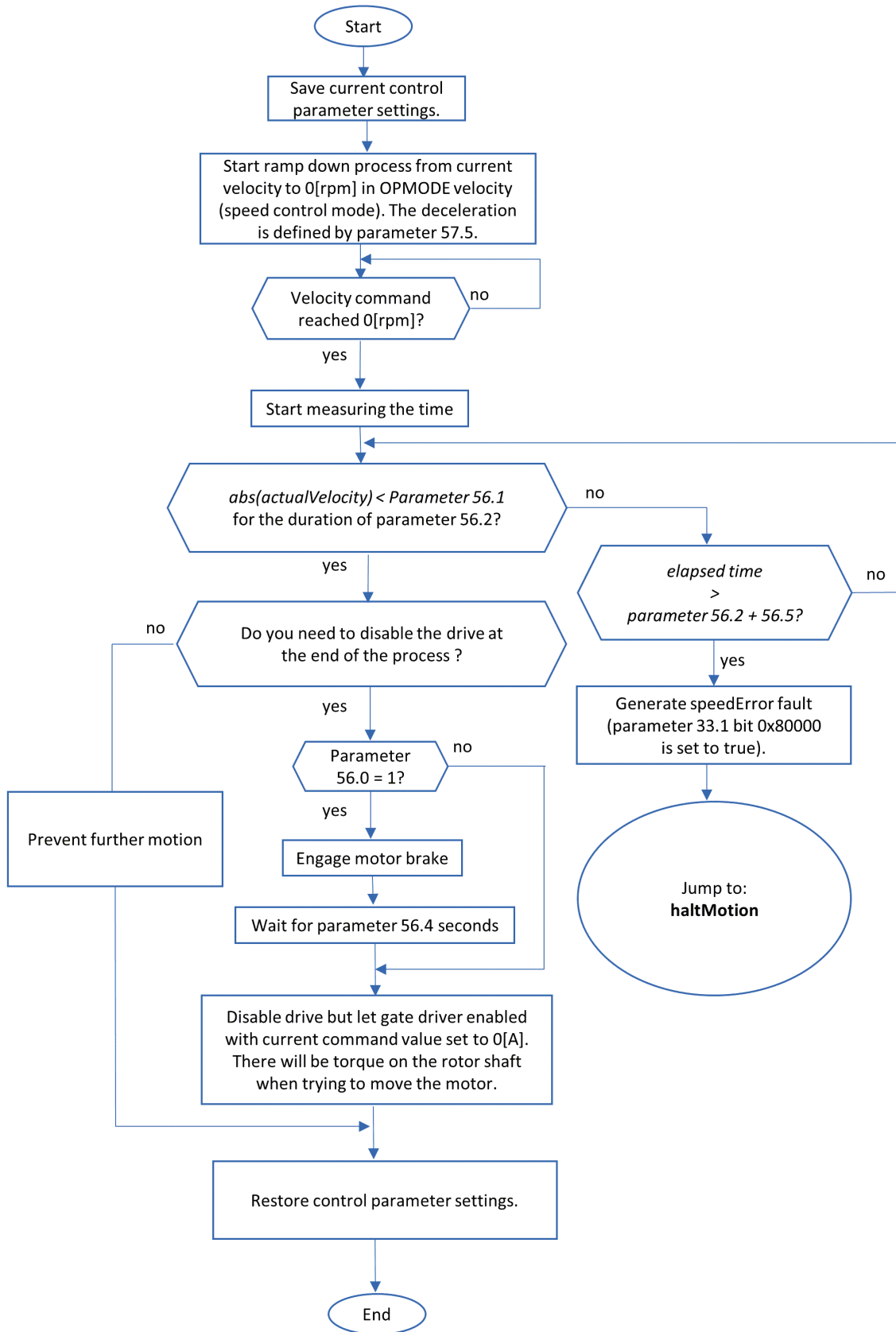

Disable via *stopMotion* (controlled ramp down in speed control mode)

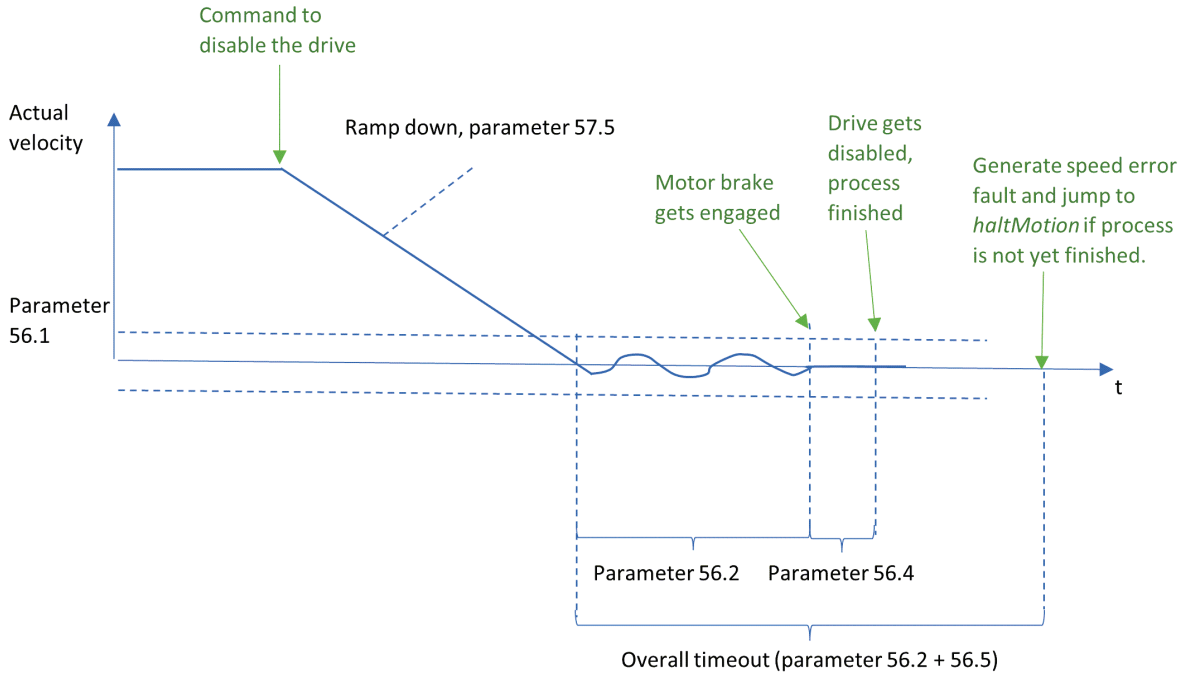

8.1 Motor Brake Control Serial Commands and CAN Objects

CAN object, sub-index	Command	ID	Index	Description
2138h, 1	Motor brake enable Data type = Integer	56	0	0 = No motor brake connected 1 = Motor brake connected
2138h 2	Velocity 0 speed window Data type = Integer Unit: [EncoderCounts/s]	56	1	The motor is considered as stopped if the actual velocity is consecutively within the following window for the time of parameter 56.2: $-56.1 < \text{actualVelocity} < 56.1$
2138h, 3	Velocity 0 time Data type: Floating Unit: [s]	56	2	The motor is considered stopped if the actual velocity is consecutively within the velocity 0 window for this amount of time. See also parameter 56.1.
2138h, 4	Motor brake disengage time Data type: Floating Unit: [s]	56	3	During an enable process the drive blocks motion command values for this amount of time while the brake is about to become disengaged (open). This prevents a moving motor, whose brake is not yet completely open, from causing damage to the brake.
2138h, 5	Motor brake engage time. Data type: Floating Unit: [s]	56	4	During a disable process, after reaching zero velocity, the drive first engages (closes) the motor brake for this amount of time before it stops generating PWM signals or commanding a current command value of 0[A]. This prevents unexpected movements of hanging load applications during a disable process.
2138h, 6	Disable timeout. Data type: Floating Unit: [s]	56	5	This overall timeout ensures that the disable process does not get stuck during a disable process; for example, due to a 56.1 setting that is too small, or a 56.2 setting that is too high.
2138h, 7	Gate driver status after haltMotion process. Data type: Integer	56	6	0 = No effect on the gate driver at the end of the process. 1 = Enables the gate driver at the end of the process.
2138h, 8	Gate driver status during haltMotion process Data type: Integer	56	7	0 = Gate driver enabled; current loop works against the current injected by back EMF. 1 = Gate driver disabled; motor rotates freely driven by load.

9 Operation

9.1 Operational Safety

Note Machine builders are responsible for machine safety implementation, testing and certification. The machine manual must define operational and maintenance conditions and safety precautions.

- Perform all machine operations in strict compliance with product specifications and installation instructions.
- The machine builder must provide a power mains disconnect device in accordance with local regulations.
- During operation, keep all covers and cabinet doors shut.
- During operation, the machine has electrically charged components and hot surfaces. The ZED heat sink can reach temperatures of 90°C. Control and power cables can carry a high voltage, even when the motor is not rotating.
- Machine axes with a suspended load or unbalanced load must have an additional mechanical safety block (such as a motor-holding brake) to prevent the load from falling out of control. The ZED cannot keep the load suspended when STO is active. Serious injury may result if the load is not properly safeguarded.

10 Maintenance

10.1 Maintenance Safety

Note | Incorrect handling of the ZED may cause personal injury and/or damage to equipment.

- Before performing maintenance on the ZED (or the machine it drives), review all relevant product documentation.
- Perform maintenance procedures in strict compliance with the product maintenance requirements and instructions.
- To prevent electric arcing and hazards to personnel and electric contacts, never disconnect or connect the product while the power source is energized.
- After disconnecting the power source from the machine, wait at least 5 minutes before touching or disconnecting parts of the machine that normally carry electrical charges (such as capacitors, contacts, screwed connections).
- Before touching the machine, measure the electrical contact points with a meter. Be certain voltage is below 30 VDC before handling components.

10.2 Troubleshooting

10.2.1 Status LED

The ZED has a LED that serves as a **status** indicator.

The location of the LED is shown in the following figure.

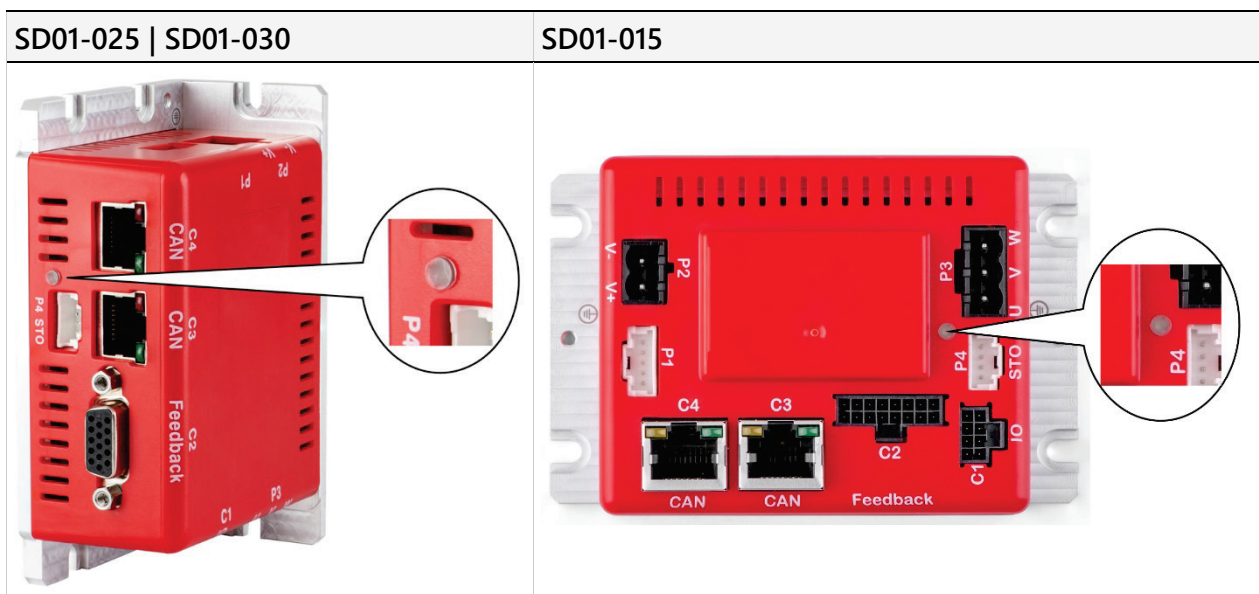

Figure 10-1 Status LED

The following diagram describes the behavior and meaning of the LED colors and states.

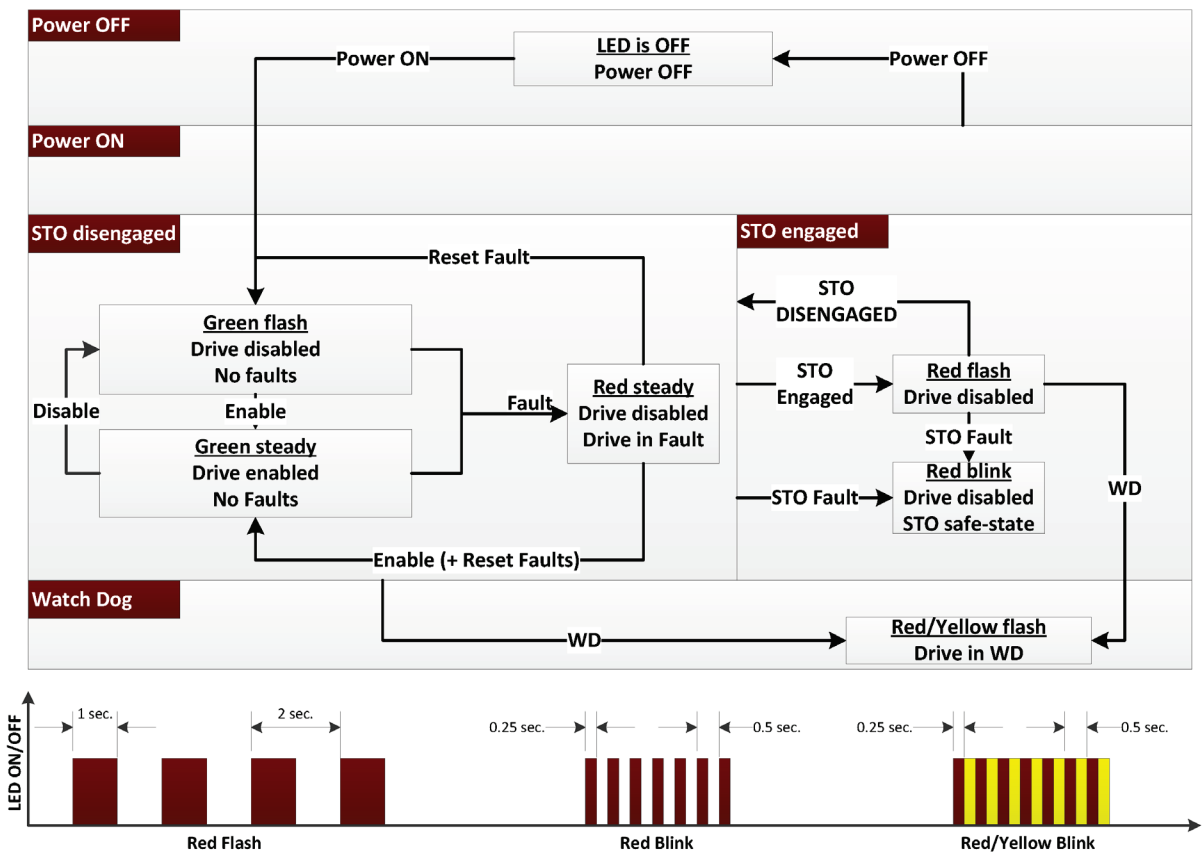

Figure 10-2 Status LED Behavior and Indications - SD01-025 | SD01-030

10.2.2 Built-in Protection

When a drive fault occurs, the fault is automatically latched and the drive is disabled. Faults must be explicitly cleared before the drive can be enabled.

10.2.3 Faults

The following table lists the fault (emergency error) codes. When an illegal state occurs in the drive, the ZED sends the code to the master device as object *TBD* (Error Code).

Whenever object *TBD* has a value other than 0, there is a fault in the drive. The CANopen state machine enters Fault mode, and the ZED cannot be enabled.

Table 10-1. Faults – to be completed

Error code	Name	Description	Action Required

10.2.4 Network Communication Issues

The following table lists the objects that can be used to troubleshoot network communication issues.

Table 10-2. Network Communication Issues – *to be completed*

Object	Name	Description

11 Functional Safety (STO)

Refer to separate document, *ZED Functional Safety User Manual*.

ZED Single-Axis Servo Drive

User Manual