

ZED Servo Drive Functional Safety

User Manual

ORIGINAL DOCUMENT
Manual Revision 2.0



Revision History

Manual Rev.	Date	Notes
Rev.2.0	19 Dec. 2023	Product name changed from servSD to ZED. Updated section: Products Approved for Functional Safety.
Rev.1.2c	30 Jan. 2023	Added figures showing SD01-015 model (all interfaces on top panel) Chapter 3: Updated table of products approved for functional safety Chapter 5: Added diagrams with SD01-015 model
Rev.1.2b	20 Dec. 2022	Chapter 2: Updated STO Certification and Reliability Data Section 4.3: Added Machine Directive 2006/42/EC - EN/ISO 13849-1:2015
Rev.1.2	4 Nov. 2021	Section 5.4: Using a Power Supply (updated text/diagram) Section 5.5: Using a PLC (updated diagram) Section 7.2: Periodic Diagnostic Test (updated text)
Rev.1.1	4 Oct. 2021	Removed servIM from title
Rev.1.0	5 Sept. 2021	Initial release

Copyright Notice

© 2023 STXI Motion Ltd.

All rights reserved. No part of this work may be reproduced or transmitted in any form or by any means without prior written permission of STXI Motion Ltd.

Disclaimer

This product documentation was accurate and reliable at the time of its release. STXI Motion Ltd. reserves the right to change the specifications of the product described in this manual without notice at any time.

Trademarks

ZED is a trademark of STXI Motion Ltd.

CANopen and CiA are registered trademarks of the CAN in Automation User's Group

Contact Information

www.stxim.com

contact@stxim.com

CANopen Vendor-ID

Vendor-ID **0513** has been registered to STXI Motion Ltd.
(specified in object 1018h sub-index 01).

Contents

1	Introduction	4
1.1	About this Manual	4
1.2	STO Function Definition	4
2	STO Certification and Reliability Data	5
3	Products Approved for Functional Safety	6
4	STO Technical Specifications	7
4.1	Electrical Specification	7
4.2	Environmental Specifications	8
4.3	Standards Compliance	8
5	Installation	9
5.1	Avoiding Uncontrolled Access to the ZED	9
5.2	STO Connector – P4	9
5.3	STO Connector Pinout	10
5.4	Using a Power Supply	10
5.5	Using a PLC	11
5.6	STO Cable Requirements	12
5.7	Mating Connector	13
6	Using STO	14
6.1	STO Benefits	14
6.2	STO Effect on Motor Movement	14
6.3	STO Effect on the ZED	14
6.4	Recovery from an STO Event	16
6.5	STO Status Information	16
6.5.1	CANopen	17
6.5.2	STO Signal Feedback	17
6.6	Prohibited Use of STO	18
7	Maintenance	19
7.1	Product Repair	19
7.2	Periodic Diagnostic Test	19
7.3	Diagnostic Test Failure	20

1 Introduction

1.1 About this Manual

Functional safety in the ZED servo drive is implemented by means of the safe torque off (STO) function, which prevents unexpected startup and uncontrolled stops. STO ensures that the drive will not provide a rotational field within the motor, thereby preventing the motor from generating a torque on the shaft.

This manual describes the characteristics and use of the STO function in the ZED servo drive.

This manual includes critical operational information, including expected behavior of motion systems when using the STO function, limitations in its use, and requirements for periodic testing by the user.

Note

The term STO function engaged means that power to the STO circuit has been removed, and power to the motor is inhibited.

1.2 STO Function Definition

The STO function is defined in standard EN/IEC 61800-5-2, and relates to an uncontrolled stop as per stop category 0 of IEC 60204-1.

Standard EN/IEC 61800-5-2, defines the functional safety requirements for adjustable speed electrical power drive systems. According to this standard, when the STO function is engaged, power that can cause motion is not applied to the motor.

The STO function may be used where power removal is required to prevent an unexpected startup.



Warning. Drives with a suspended load must have an additional mechanical safety block (such as a motor-holding brake) since the drive cannot hold the load when STO is engaged. Serious injury could result if the load is not properly safeguarded.

The STO function in the ZED removes power from the gate driver of the power module, effectively inhibiting PWM pulses from driving the power devices that enable power flow to the motor.

2 STO Certification and Reliability Data

STO implementation on the ZED has been certified by TuV SUD Rail GmbH. The following table shows the functional safety data for the ZED drive.

Characteristic	Product Values	Remark
PFH [h ⁻¹]	< 12 E-9	Failure rates are based on SN29500 at an ambient temperature of 50°C
SFF [%]	> 90% (HFT=1)	
MTTFD [years]	High	
CAT	3	
PL	e	
SIL	3	
SILCL	3	
DC [%]	>95%	
Lifetime	20 years	

Note: Subject to periodic diagnostic testing. Refer to section *Periodic Diagnostic Test*.

3 Products Approved for Functional Safety

The following ZED product models are certified for STO functional safety:

	SD01 - 030	1D	AB	CA	-	000
ZED Single-Axis Servo Drive						
Rating – Cont. Current, Peak Current						
015	12/14.4 (*) 40 Arms @ 24 VDC					
025	18/20 (*) 63 Arms @ 48 VDC					
030	20/23 (*) 70 Arms @ 24 VDC					
xxx	Custom					
Power						
1D	Bus 20-60 VDC, Logic 24 VDC optional					
xx	Custom					
Feedback						
AB	Incremental AB quad, index, Halls, 12-bit RS422					
AS	Absolute SSI					
xx	Custom					
Communication						
CA	CANopen					
xx	Custom					
Options						
000	Standard					
xxx	Custom					

(*) Requires external heatsink. Refer to *ZED User Manual*.

4 STO Technical Specifications

4.1 Electrical Specification

Feature	Details	Specification
STO supply voltage	Nominal voltage	24 VDC
	Voltage levels in accordance with Type 2 EN 61131-2	11–30 VDC: STO function not engaged (motion allowed) 0–5 VDC: STO function engaged (motion inhibited) 5–11 VDC: functionality is neither defined nor guaranteed
	Power supply characteristics	Must be a SELV/PELV power supply. Refer to section <i>Using a Power Supply</i> .
Current drain	At 24 VDC	Less than 5mA
Maximum reaction time	Time within which the motion is inhibited	100 ms
Maximum duration of PLC/OSSD test pulse	Test pulse is ignored by the drive	10 ms
Minimum duration of PLC/OSSD test pulse		TBD
Maximum frequency of PLC/OSSD test pulses	Absolute maximum frequency of test pulses that will be successfully filtered by the drive	2Hz

4.2 Environmental Specifications

Feature	Specification
Operation ambient temperature	0–45°C
Storage ambient temperature	0–70°C
Relative humidity	10–90%
Altitude	According to the used clearances, based on IEC 61800-5-1, the ZED is rated for use up to an altitude of 2000 m
Vibration	Per IEC 61800-5-1:2007: <ul style="list-style-type: none"> ▪ 1g sine vibration from 10 Hz to 150 Hz
Shock	Per EC 61800-2:2021: <ul style="list-style-type: none"> ▪ 5g half-sine for 30 msec
Protection class/ Pollution degree	Protection class: IP20, pollution degree: 2 as per IEC 60664-1 The product is defined IP20, but the product must be mounted within an IP54 or better enclosure Do not use in the following locations: corrosive or flammable gasses, water oil or chemical, dust including iron dust and salts

4.3 Standards Compliance

The following table shows Directives and the relevant Standards.

EU Directive	Standard(s)
Machine Directive 2006/42/EC	EN IEC 61800-5-2:2016 EN IEC 62061:2005 + A1:2012 + A2:2015 (SIL CL 3) EN/ISO 13849-1:2015
EMC Directive 2014/30/EU	EN IEC 61800-3 EN IEC 61000-6-7:2014
RoHS Directive 2011/65/EU	EN IEC 63000:2018

5 Installation

5.1 Avoiding Uncontrolled Access to the ZED

ZED installation must be done such that personnel access is limited. For example: locked cabinets, inaccessible position.

In other words, access to the product must be limited to trained personnel only.

5.2 STO Connector – P4

STO uses connector P4. The following image shows the location of connector P4 on the various ZED models.



SD01-025 | SD01-030

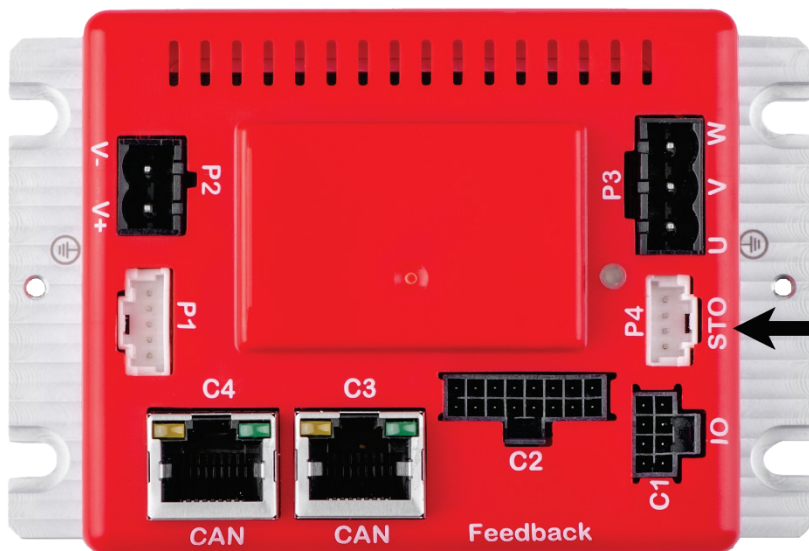

SD01-015

5.3 STO Connector Pinout

The following table shows the pinout of the STO connector.

Pin	Pin Label	Function
1	STO1	STO1 input
2	STO Feedback	STO signal feedback
3	STO2	STO2 input
4	STO Return	STO signal return

5.4 Using a Power Supply

A typical STO system configuration, with a power supply as the source of the STO voltage, is shown in the figure and includes the following components:

- ZED with two STO inputs
- SELV/PELV power supply
- Safety-certified Emergency stop or other switch to cut the power to the STO
- Two normally-closed switches that are used for periodic diagnostic testing

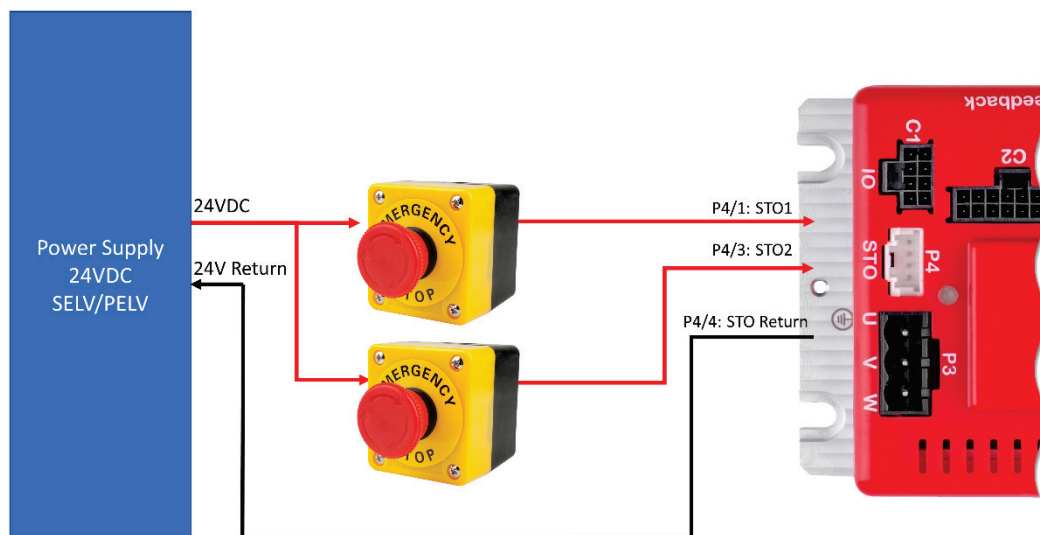

SD01-015

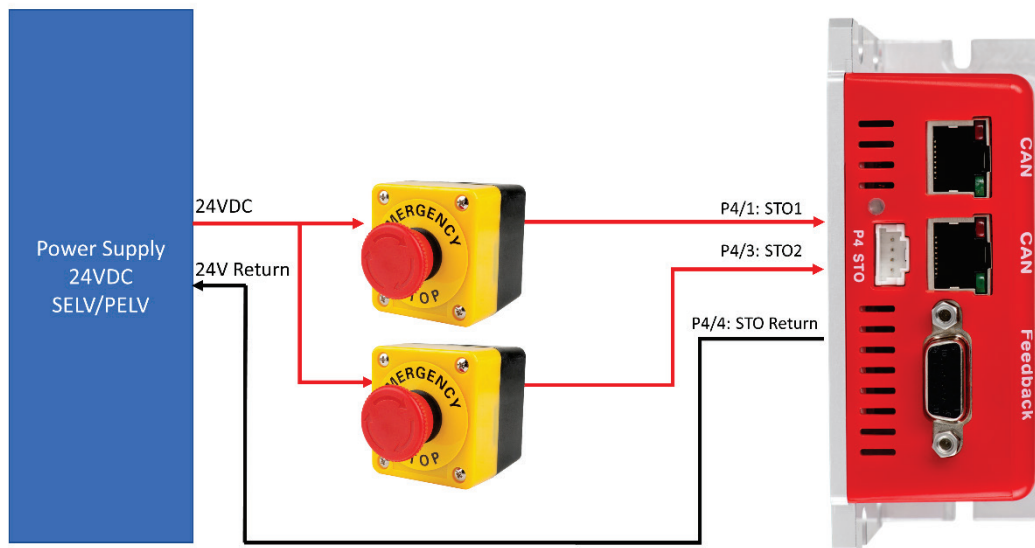

SD01-025 | SD01-030

Notes:

- The 24VDC power supply unit must comply with PELV/SELV, as per EN 60204-1 (*Safety of Machinery - Electrical Equipment of Machines - Part 1: General Requirements*). The output voltage shall not exceed 60VDC under normal or failure conditions.
- A single E-stop button connects the Power Supply to both STO inputs.
- Two normally-closed switches must be installed, for use in SIL 3 / PLe / CAT 3 installations, so that each STO input can be tested individually. Refer to the chapter *Maintenance*. It is recommended to lock these switches in the electrical cabinet to avoid misuse, and to label them "STO OFF/ON" switches, intended for use by maintenance personnel only.

5.5 Using a PLC

A PLC can be used to source the 24VDC to the STO inputs, as shown in the figure below. In that case, the PLC should be a Safe PLC.

The PLC output should ideally support test pulses. The test pulses are used for diagnostics of the STO input circuit. The PLC return should be used by the PLC for diagnostics.

Test pulses on the two channels must be separated in time in order for the PLC to do the diagnostics. This is because there is a single PLC return line, and the PLC signals are wired-OR on this line.

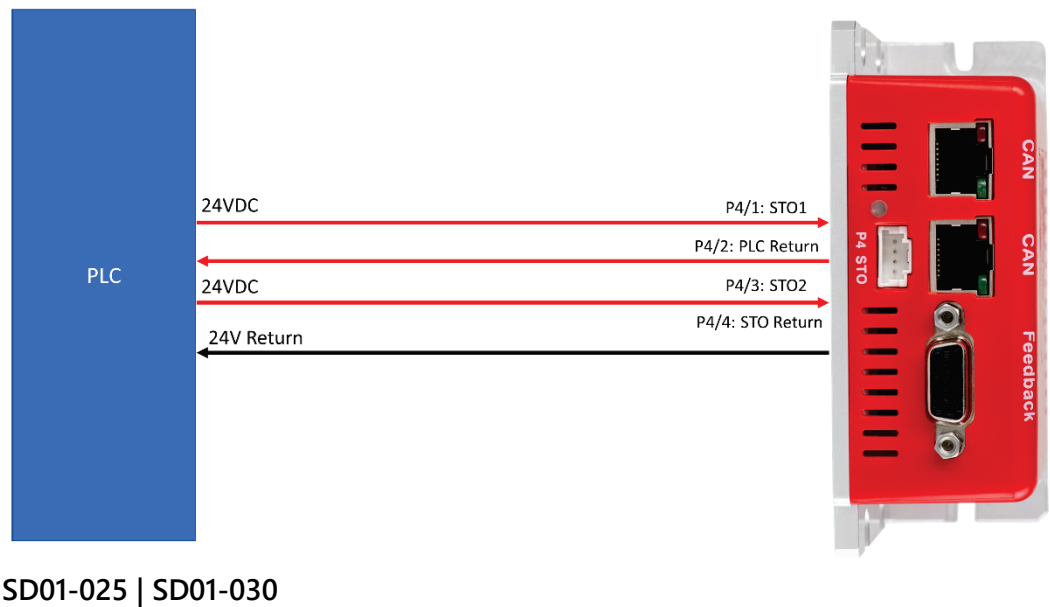
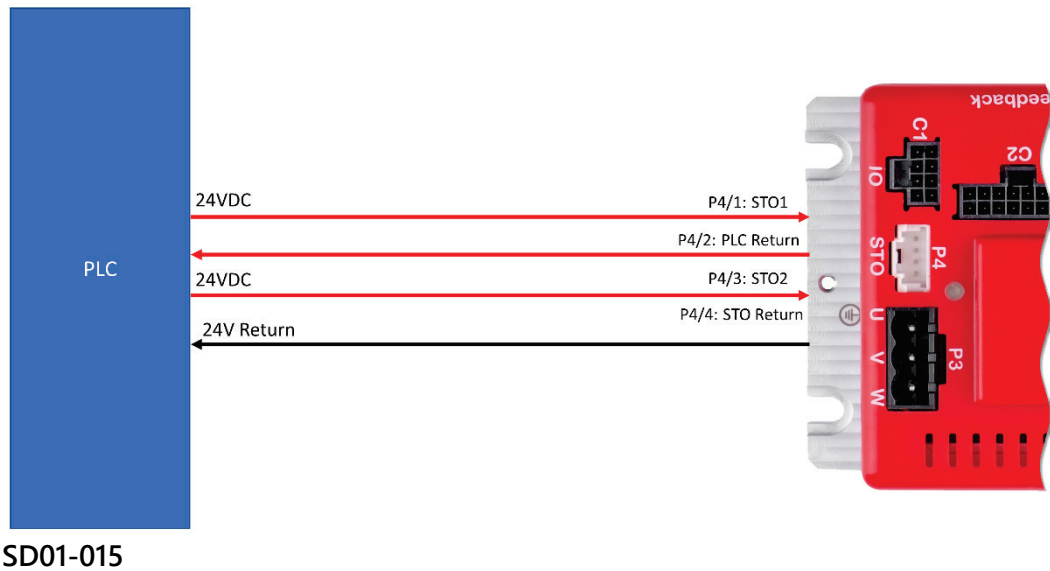

5.6 STO Cable Requirements

The STO cable must be no more than 30 meters in length.

The cable does not need to be shielded.

Double insulated cables must be used, in order to avoid a short circuit between the two STO signals.

The wire gauge for the cable wire must be between 22 AWG and 28 AWG, per the specifications of the connector and mating connector.

The STO cable must be spatially separated from any sources of environmental stress, be it mechanical, electrical, thermal or chemical.

5.7 Mating Connector

The following table shows the specifications for the mating connector:

Item	All Models
Manufacturer	Molex
Housing PN	51382-0400
Pin crimp PN (need 4 crimp pins per connector)	561349000 or 561349002 or 561349100
Wire gauge	22-28 AWG

6 Using STO

6.1 STO Benefits

The advantage of the integrated STO safety function over standard safety technology using electromechanical switchgear is the elimination of separate components and the effort required to wire and service them.

In addition, the function has a shorter switching time than the electromechanical components in conventional safety solutions.

6.2 STO Effect on Motor Movement

The STO function serves exclusively to provide a safe stop of the motion system according to the STO specification in IEC 61800-5-2. Triggering the STO function results in power being removed from the motor control circuits, and, as a result the motor is without control. When STO is triggered while the motor is in motion, the motor shaft and its linked mechanical elements coast until brought to a stop by their own friction.

The immediate effect of STO is that the drive cannot supply any torque-generating energy. STO can be used in applications where the motor is expected to reach a standstill within a sufficiently short time based on the load and friction, and when coasting down of the motor will not have any impact on safety.

6.3 STO Effect on the ZED

The Enable/Disable state of the ZED, and the indication of a Fault, are shown in the GUI. The following screenshot of the upper left-hand side of the GUI shows the normal, Enabled state of the drive.

- Fault status is indicated under "Driver Failures"
- Drive enable state is shown by the Motor being ON

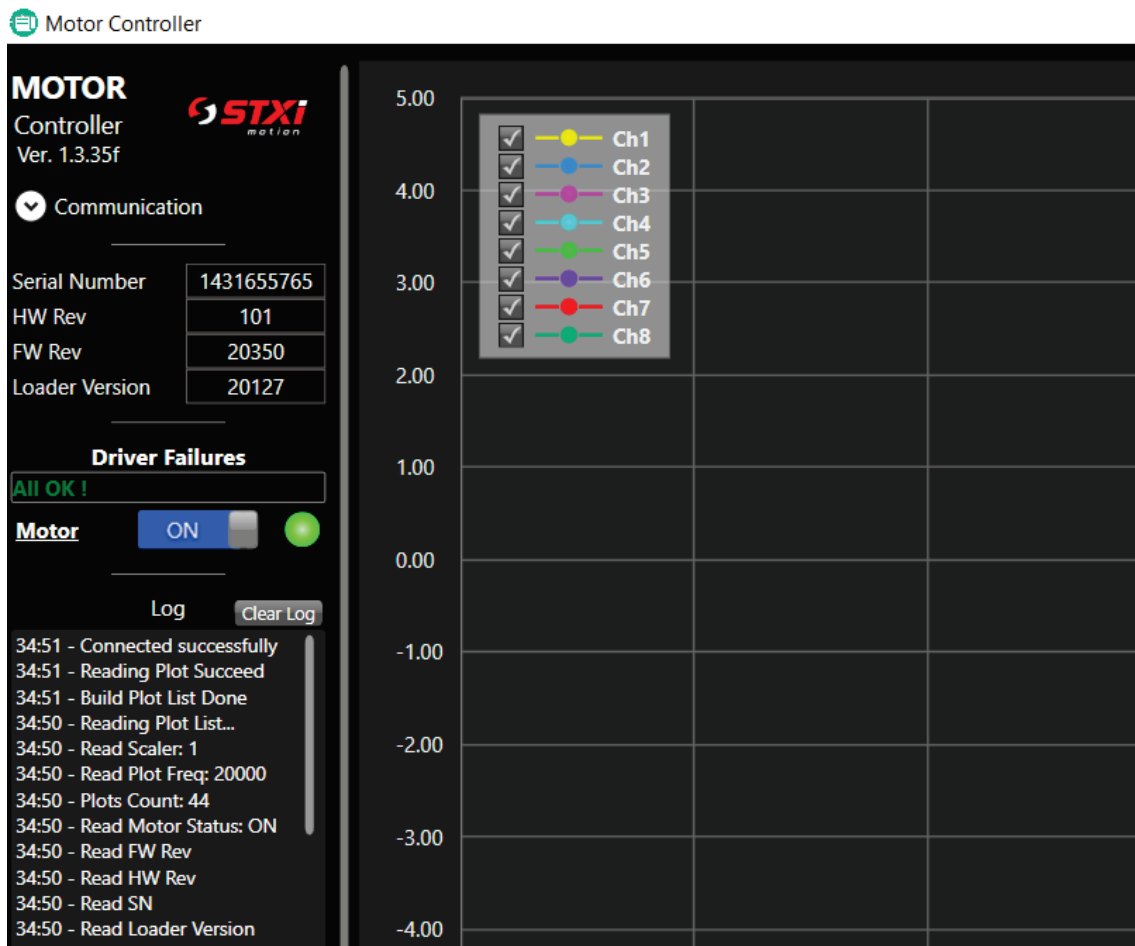

When the STO is engaged the ZED goes into the Disable state and the STO Fault is latched. This means that motion cannot be commanded. The GUI shows that there is an STO fault and the motor (drive enable state) is OFF.



6.4 Recovery from an STO Event

When the STO is engaged, the STO state is latched as a fault in the drive, and the drive is disabled.

Recovery requires the user to do the following:

- Return voltage to the STO input and to
- Explicitly enable the drive (by clicking on the Motor OFF icon).

The Enable process checks that the STO fault no longer exists, and then enables the drive.

Note When the voltage is returned to the STO input, the drive remains in the Disable state until the user explicitly enables the drive.

6.5 STO Status Information

In addition to STO status being shown on the GUI as described above, the STO status information is available in the following ways.

6.5.1 CANopen

The STO status is reflected in the Fault Status Register. There is only one bit (bit 16) that updates STO general status (STO0 and STO1)

- CANopen object 0x2121 / 02
- Register bit map

Bit	Error Name	Error Type	Fail when
0	Hall Error	Motor	Input (0,0,0) or (1,1,1) or Halls order incorrect
1	Parameters Checksum	Init	Parameters corruption
2	Encoder/Hall Sync	Motor	Encoder/Hall problem
3	Over Temperature	Motor	Above 105°C
4	Over Voltage	Motor	Supply voltage above 42V
5	Under Voltage	Motor	Supply voltage below 12V
6	Com Sync Loss	Comm	Master does not communicate
7	Position Tracking	Motor	Position loop error above "Max tracking error"
8	Driver Power Init	Init	Internal initialization test
9	Driver Power C/T	Driver	Current/Temperature HW protection
10	Driver Power Fault	Driver	Internal continues test
11	Motor Stall	Motor	See "Motor Stall" parameters
12	Gate Disabled	Motor	Gate Driver disable motion
13	Driver OSC	Init	DSP oscillator clock fail
14	Driver ADC offset	Init	Internal sensors initialization test
15	Driver Short Test	Motor	Internal driver error
16	STO	Motor	STO disable motion
17	Drv SSI not ready	Driver	Internal driver error
18	Drv83xx Setup	Driver	Internal driver error
19	Speed Error	Motor	Speed not reached
20	Param Table Rev	Init	New software

6.5.2 STO Signal Feedback

This signal, available on pin 2 of the STO connector P4, reflects the state of the STO input signal only and does not necessarily reflect the actual state of the STO function.



Caution. This signal cannot be used as a functionally safe indication of the state of the STO safety function.

6.6 Prohibited Use of STO

The STO function must not be used in conditions where external influences will create a hazard when the function is engaged, as for example, the dropping of a suspended load.

The STO function is specifically prohibited for use in elevator applications.

In these cases, additional measures (such as mechanical brakes) are required to prevent any hazard.

7 Maintenance

7.1 Product Repair

There are no user-repairable parts in the ZED. In the event of failure of a diagnostic test (or any other product failure), the entire product needs to be removed and replaced, and the defective part must be returned to the manufacturer for diagnosis and repair.

7.2 Periodic Diagnostic Test

When a power supply is used to power the STO, a periodic diagnostic test is needed as described below. However, when a PLC with test pulses is used, then the periodic diagnostic test is not needed as long as the PLC has the ability to read and process the STO feedback signal.

Per IEC 61800-5-2 section 6.2.2.1.4 (Diagnostic test interval when the hardware fault tolerance is greater than zero):

- For SIL 3 / PL e / category 3 compliance, users must perform a manual test of the STO function once every three months.
- For SIL 2 / PL d / category 3 compliance, users must perform a manual test of the STO function once every year.

The diagnostic test entails removing the STO supply voltage and verifying that the drive is indeed in the STO Fault state, and that motion is inhibited. This must be done for each STO channel individually. After testing of each channel individually, the product must be run to verify that after each test the product works as expected.

During the test, no change is allowed to be made in cabling or location of cables.

The maintenance procedure is performed as follows:

1. Set up the system such that nominal STO voltage is supplied to the drive on both STO channels, and that the drive is enabled.
2. Remove (or switch off) the voltage to the STO. Verify that:
 - The drive is in a Fault state, and the STO Fault is indicated.
 - The drive cannot be enabled.
3. Restore the STO voltage, and clear the fault. Verify that the drive can be enabled.
4. Repeat the cycle for both STO channels **individually**.

7.3 Diagnostic Test Failure

The diagnostic test is considered to have failed if, when the STO input voltage is removed, the drive either continues to be enabled or an STO fault state is not seen. In either case, the STO function is not working as expected and further use of the STO function is prohibited.

The test setup and results must be reported to the product manufacturer.

ZED Servo Drive

Functional Safety User Manual