



CANopen for servSD | servIM

User Manual

ORIGINAL DOCUMENT
Manual Revision 3.1

Revision History

Manual Rev.	Date	Notes
3.1	18 January 2023	Updated section Process Data Communication. Deleted object: 1200h Added objects: 2107h, 2110h, 2111h, 6064h, 607Ah, 607Ch, 6081h, 6098h, 6099h, 909Ah Updated all object data according to ServSD EDS file v1.17
3.0	7 Mar. 2022	Renamed manual. Added servIM integrated servo motor.
2.0	16 Nov. 2021	Added new objects.
1.2	25 July 2021	Fixed cover and page footers "servSD CANopen User Manual"
1.1	22 July 2021	updated object 1018h
1.0	8 July 2021	Initial release

Copyright Notice

© 2023 STXI Motion Ltd.

All rights reserved. No part of this work may be reproduced or transmitted in any form or by any means without prior written permission of STXI Motion Ltd.

Disclaimer

This product documentation was accurate and reliable at the time of its release. STXI Motion Ltd. reserves the right to change the specifications of the product described in this manual without notice at any time.

Trademarks

servSD and servIM are trademarks of STXI Motion Ltd.
CANopen and CiA are registered trademarks of the CAN in Automation User's Group

Contact Information

www.stxim.com

contact@stxim.com

CANopen Vendor-ID

Vendor-ID **0513** has been registered to STXI Motion Ltd.
(specified in object 1018h sub-index 01).

Contents

1	Introduction	
1.1	About This Manual	6
1.2	Manual Format – Object Dictionary	6
2	Fieldbus Wiring and Setup	
2.1	Wiring Guidelines	8
2.2	CANopen Network Wiring	9
2.2.1	CAN interfaces (C3, C4)	9
	ServSD	9
	ServIM	9
2.2.2	Termination Resistor	10
2.2.3	Cable Connections	11
2.3	Node Address in CANopen Network	11
2.4	EDS File	11
3	CANopen Operation	
3.1	Device Communication	12
3.2	Communication Objects	13
3.2.1	Service Data Communication	13
3.2.2	Process Data Communication	13
3.3	Device Control and State Machine	14
3.4	Indicating the Operating State	15
3.5	Changing the Operating State	17
4	Mandatory Objects	
	Object 1000h – Device Type	18
	Object 1001h – Error Register	18
	Object 1018h – Identity	18
5	Communication Objects	
	Object 1003h – Predefined Error Field	20
	Object 1005h – COB-ID SYNC	22
	Object 1006h – Communication Cycle Period	22
	Object 1008h – Manufacturer Device Name	23
	Object 1009h – Manufacturer Hardware Version	23
	Object 100Ah – Manufacturer Software Version	23
	Object 1010h – Store Parameter Field	23
	Object 1011h – Restore Default Parameters	24
	Object 1014h – COB-ID EMCY	24
	Object 1016h – Consumer Heartbeat Time	25
	Object 1017h – Producer Heartbeat Time	26
	Object 1400h – Receive PDO Communication Parameter 1	26
	Object 1401h – Receive PDO Communication Parameter 2	27
	Object 1402h – Receive PDO Communication Parameter 3	28
	Object 1403h – Receive PDO Communication Parameter 4	30
	Object 1600h – Receive PDO Mapping Parameter 1	31
	Object 1601h – Receive PDO Mapping Parameter 2	32
	Object 1602h – Receive PDO Mapping Parameter 3	33
	Object 1603h – Receive PDO Mapping Parameter 4	33
	Object 1800h – Transmit PDO Communication Parameter 1	34
	Object 1801h – Transmit PDO Communication Parameter 2	35

Object 1802h – Transmit PDO Communication Parameter 3.....	37
Object 1803h – Transmit PDO Communication Parameter 4.....	39
Object 1A00h – Transmit PDO Mapping Parameter 1	41
Object 1A01h – Transmit PDO Mapping Parameter 2	41
Object 1A02h – Transmit PDO Mapping Parameter 3	42
Object 1A03h – Transmit PDO Mapping Parameter 4	43

6 Manufacturer Specific Objects

Object 20F0h – NMT After Boot	44
Object 2100h – Error Code.....	44
Object 2101h – Enable Drive	45
Object 2103h – Current Command.....	46
Object 2104h – Speed Command	46
Object 2105h – Position Command.....	47
Object 2106h – Calibration	49
Object 2107h – Signal Generator Command.....	55
Object 210Ch – Brake.....	58
Object 210Fh – Bode Plot Configuration.....	58
Object 2110h – Digital Inputs Mode.....	60
Object 2111h – Digital Inputs Polarity.....	62
Object 2118h – Commutation Feedback.....	63
Object 2119h – Speed Feedback	64
Object 211Ah – Position Feedback.....	65
Object 211Dh – Digital I/O Status.....	68
Object 211Eh – Current Feedback.....	71
Object 2120h – Temperature	73
Object 2121h – Drive Status	73
Object 2132h – Motion Parameters	77
Object 2133h – Motor Parameters.....	81
Object 2134h – Current Protection.....	83
Object 2135h – Motor Limits.....	84
Object 2136h – Position Profile.....	87
Object 2138h – Stop Motion Parameters.....	89
Object 2139h – Speed Profile	92
Object 213Dh – Device Communication.....	95
Object 213Eh – Device Parameters.....	96
Object 213Fh – Save/Load Parameters	99
Object 2146h – Hall Parameters	100
Object 2147h – Encoder 1 Parameters	105
Object 2149h – SSI Parameters	110
Object 214Eh – Interpolation Gear	116
Object 2151h – Current PID.....	117
Object 2152h – Speed PID	121
Object 2153h – Position PID.....	124
Object 2154h – Hall Map	128
Object 2165h – Current IIR Filter	130
Object 216Eh – Analog Command.....	133

7 Device Objects

Object 603Fh – Error Code.....	137
Object 6040h – Controlword.....	138
Object 6041h – Statusword.....	139
Object 605Ah – Quick Stop Option Code	139
Object 605Dh – Halt Option Code.....	140

Object 605Eh – Fault Response Option Code	140
Object 6060h – Modes of Operation	141
Object 6061h – Modes of Operation Display	142
Object 6062h – Position Demand Value	142
Object 6064h – Position Actual Value	143
Object 606Bh – Velocity Demand Value	143
Object 606Ch – Velocity Actual Value	143
Object 606Dh – Velocity Window	144
Object 606Eh – Velocity Window Time	144
Object 6073h – Maximum Current.....	144
Object 6075h – Motor Rated Current	145
Object 6078h – Current Actual Value	145
Object 607Ah – Target Position	146
Object 607Ch – Home Offset	147
Object 607Eh – Polarity	148
Object 607Fh – Maximum Profile Velocity.....	148
Object 6080h – Motor Maximum Speed	149
Object 6081h – Profile Velocity in Position Profile Mode.....	149
Object 6083h – Profile Acceleration	149
Object 6084h – Profile Deceleration	150
Object 6085h – Quick Stop Deceleration	150
Object 608Fh – Position Encoder Resolution.....	151
Object 6090h – Velocity Encoder Resolution.....	152
Object 6091h – Fieldbus Gear Ratio	153
Object 6092h – Feed Constant	154
Object 6098h – Homing Method.....	155
Object 6099h – Homing Speeds.....	155
Object 609Ah – Homing Acceleration	156
Object 60C2h – Fieldbus Interpolation Time	157
Object 60C5h – Maximum Acceleration	158
Object 60C6h – Maximum Deceleration.....	158
Object 60FFh – Target Velocity	159
Object 6502h – Supported Drive Modes.....	159

8 Units

8.1 Units Overview	160
8.2 Position Unit Conversion	160
8.3 Velocity Unit Conversion	161
8.4 Acceleration/Deceleration Unit Conversion.....	162

1 Introduction

1.1 About This Manual

Drive functionality is configured using various commands and variables, which are communicated over the serial port or over a fieldbus.

This manual describes the implementation of CANopen communication in the servSD servo drive and the servIM integrated servo motor.

This manual is not meant to replace the CANopen specifications, or to reproduce them.

This manual is intended for skilled personnel who have been trained to work with the equipment described.

1.2 Manual Format – Object Dictionary

The CAN objects are presented and described in the following formats:

Variable and Record Objects

nnnh – Object Name

Description	Description of the object
Object Type	Variable Record
Data Type	Boolean Integer8 Integer16 Integer32 Unsigned8 Unsigned16 Unsigned32 Real32 Visible_String
Access	Read/Write Read and write access Read only Read only Constant Read only access, value is constant
PDO Mapping	Yes No
Default Value	The object's default value.
Lower Limit	The object's minimum value.
Upper Limit	The object's maximum value.
Unit	When the object value implies units of measure, these units are specified.

Array Objects**nnnnh – Object Name**

Description	Description of the object
Object Type	Array
Sub-indices	The number of object sub-indices.
Sub-index	0
Description	Description of the sub-index.
Object Type	Variable Record
Data Type	Boolean Integer8 Integer16 Integer32 Unsigned8 Unsigned16 Unsigned32 Real32 Visible_String
Access	Read/Write Read and write access Read only Read only Constant Read only access, value is constant
PDO Mapping	Yes No
Default Value	The default value.
Lower Limit	The minimum value.
Upper Limit	The maximum value.
Unit	When the value implies units of measure, these units are specified.

2 Fieldbus Wiring and Setup

2.1 Wiring Guidelines

To ensure proper performance, wiring must be in accordance with the following guidelines:

- Use and connect components and cables according to manufacturer specifications.
- Use the shortest cables possible.
- To reduce the effects of EMI, use twisted pairs for the following cables:
 - Power supply
 - CANopen communication
- Twisting must be maintained as close as possible to both ends of the cable.
- Shielding must be maintained at both ends of the cable.
- If connecting the power supply unit (PSU) to more than one servSD/servIM, use either a star or a bus connection, as shown in the figures below.

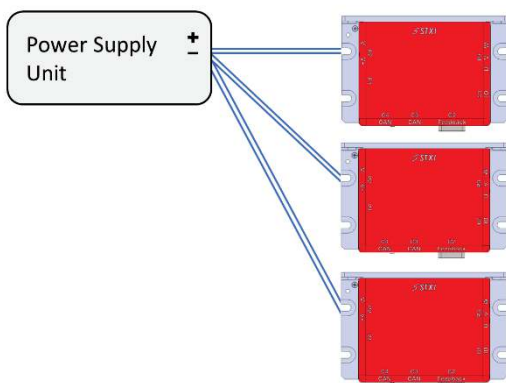

Figure 1. Star Connection

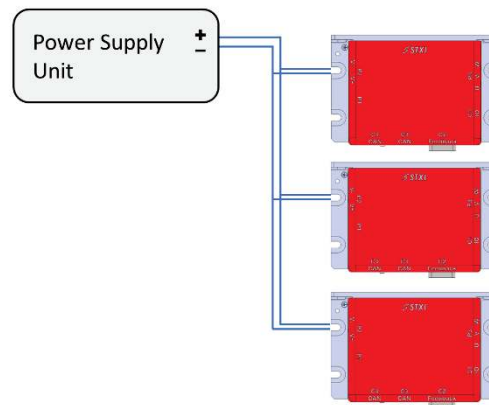

Figure 2. Bus Connection

2.2 CANopen Network Wiring

The nodes of the CANopen network are connected in series, so that the CAN cabling loops through all controllers.

2.2.1 CAN interfaces (C3, C4)

ServSD

Interfaces C3 and C4 are RJ45 ports that serve as transmitter and receiver for drives operating on a CAN network. They have identical pinouts.

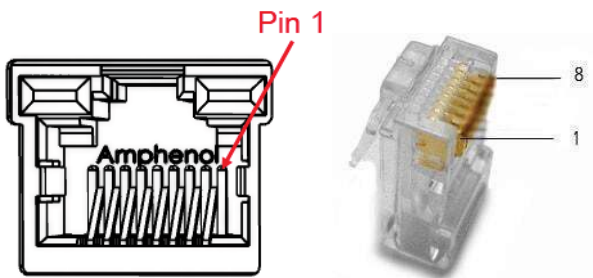

Figure 3. servSD CAN interface (C3, C4) and connector

Pin #	Signal Description
1	CAN high
2	CAN low
3	CAN ground
4	RS232 receive
5	RS232 ground
6	RS232 transmit
7	<i>not connected</i>
8	<i>for manufacturer use only</i>

ServIM

Interfaces C3 and C4 are M8, 6-pin connectors that serve as transmitter and receiver for drives operating on a CAN network. They have identical pinouts.

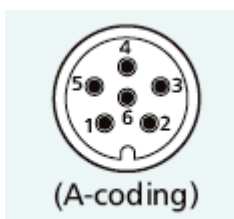

Figure 4. servIM CAN interface (C3, C4) and connector

Pin #	Signal Description
1	CAN high
2	CAN low
3	CAN ground
4	RS232 receive
5	RS232 ground
6	RS232 transmit

2.2.2 Termination Resistor

A 120 Ω termination resistor is required at both ends of the CAN bus network between CAN_L and CAN_H. This is the responsibility of the user.

The following figure shows an example of the placement of termination resistors in a system with more than two devices.

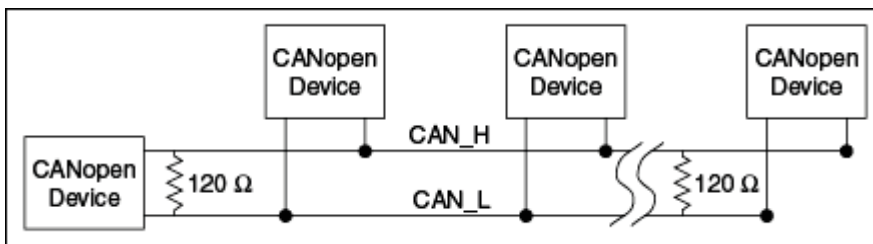

Figure 5. Placement of terminator resistors

2.2.3 Cable Connections

servSD wiring requires RJ45 Cat 5e cables.

servIM wiring requires M8 6-pin fieldbus cables.

Make the following connections:

- Connect the host to the drive on interface C4.
- Connect the next node to interface C3
- Connect a termination resistor plug to interface C4 on the last CANopen device in the network chain.

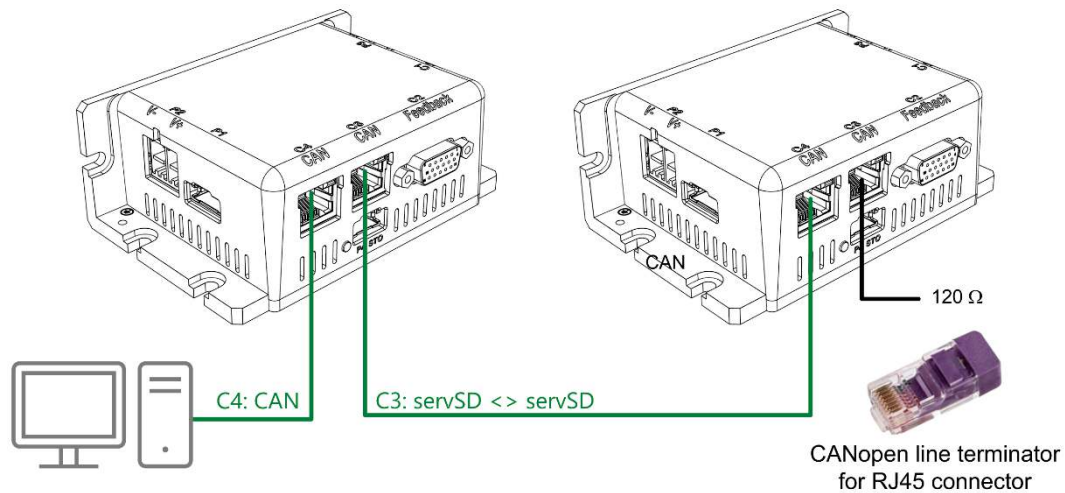

Figure 6. servSD CAN Network Configuration

2.3 Node Address in CANopen Network

Within a CANopen network, a unique node address (identification number) must be allocated to each individual CANopen device.

If only one drive is connected to the host computer, the drive address is set to 127 by default and does not need to be defined.

When using multiple drives in the same CANopen network, each drive must have a unique address.

2.4 EDS File

When setting up your system for CANopen communication, be sure the required EDS file is installed in the PLC controller or host computer.

You can download the file from the STXI Motion website or contact Technical Support.

3 CANopen Operation

3.1 Device Communication

The servSD/servIM communication interface conforms to the following standards:

- CiA 301: CANopen Application Layer and Communication Profile
- IEC 61800-7-1: Interface Definition; (previously CiA 402-1: General Definitions)
- IEC 61800-7-201: Profile Type 1 (CiA 402); (previously CiA 402-2: Operation Modes and Application Data)
- IEC 61800-7-301: Mapping of Profile Type 1; (previously CiA 402-3: PDO Mapping)

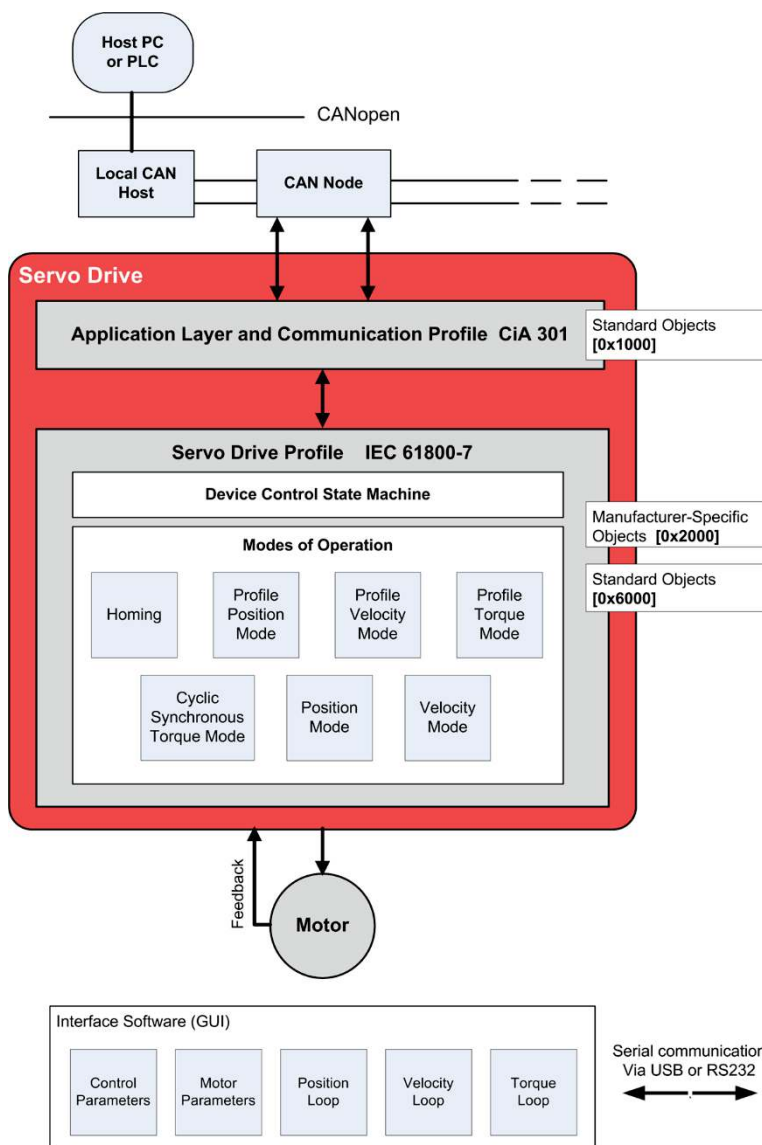

Device Control: Starting and stopping of the drive and several mode-specific commands are executed by the state machine.

Modes of Operation: The operating mode defines the behavior of the drive.

Figure 7. Communication Architecture

3.2 Communication Objects

Communication objects are used for exchanging process and service data, for process or system time synchronization, for error state supervision, and for control and monitoring of node states. These objects are defined by their structure, transmission types and their CAN identifier.

3.2.1 Service Data Communication

Service data objects (SDOs) provide direct access to object entries in the CANopen device object dictionary. As these object entries contain data of arbitrary size and data type, the SDOs are used to transfer multiple data sets (each containing an arbitrary large block of data) from a client to a server and vice versa. The client controls, via a multiplexer (index and sub-index of the object dictionary), which data set is transferred. The content of the data set is defined within the object dictionary.

In general, an SDO is transferred as a sequence of segments. Prior to transferring the segments there is an initialization phase in which client and server prepare for transferring the segments. For SDOs, it is also possible to transfer a data set of up to four bytes during the initialization phase. This mechanism is called SDO expedited transfer.

The client always initiates an SDO transfer for any type of transfer. The owner of the accessed object dictionary is the server of the SDO. Either the client or the server can take the initiative to abort the transfer of an SDO.

By means of an SDO, a peer-to-peer communication channel between two CANopen devices is established. A CANopen device supports more than one SDO. One supported Server-SDO is the default case (Default SDO).

3.2.2 Process Data Communication

Process data objects (PDOs) perform real-time data transfer. The transfer of PDOs is performed without any protocol overhead.

The PDOs correspond to objects in the object dictionary and provide the interface to the application objects. Data type and mapping of application objects into a PDO is determined by a corresponding default PDO mapping structure within the object dictionary. servSD/servIM support variable PDO mapping; therefore, the number of PDOs and the mapping of application objects into a PDO may be transmitted to a CANopen device during the configuration process, by applying the SDO services to the corresponding objects of the object dictionary.

PDOs are used for both data transmission and data reception – termed Transmit-PDO (TPDO) and Receive-PDO (RPDO), respectively. CANopen devices supporting TPDO are PDO producers, and CANopen devices supporting RPDO are called PDO consumers. servSD/servIM support both. The PDO communication parameter describes the communication capabilities of the PDO. The PDO mapping parameter contains information about the contents of the PDO.

For each PDO, a pair of communication and mapping parameters is mandatory.

Only event-triggered RPDOs are supported.

3.3 Device Control and State Machine

The power drive system finite-state automaton (PDS FSA) is a mathematical model that defines the behavior of the power drive system. Because a power drive system is required to provide local control even when the communication network is not functioning properly, the communication FSA and the PDS FSA are only loosely coupled. Figure shows how the power drive system operates remotely via the network, or locally.

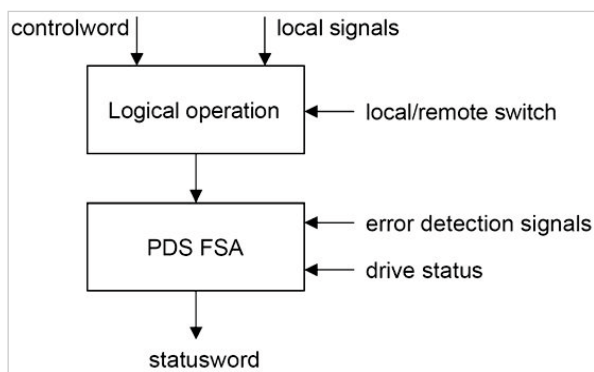

Figure 8. Remote and Local Control

The power drive system is operated by the Controlword sent by the control device via the network. The state of the power drive system is reported by the Statusword produced by the drive device. The FSA is also controlled by error detection signals.

The PDS FSA defines the power drive system status and the possible control sequence of the power drive system. A single state represents a special internal or external behavior. The state of the power drive system also determines which commands are accepted. For example, it is only possible to start a point-to-point move when the drive is in the operation enabled state.

3.4 Indicating the Operating State

After switching on, and when an operating mode is started, the power drive system goes through a number of operating states. The operating states are internally monitored and influenced by monitoring functions

The following figure illustrates the PDS FSA behavior. It takes into consideration the control of the power electronics, in accordance with user commands and internal drive faults.

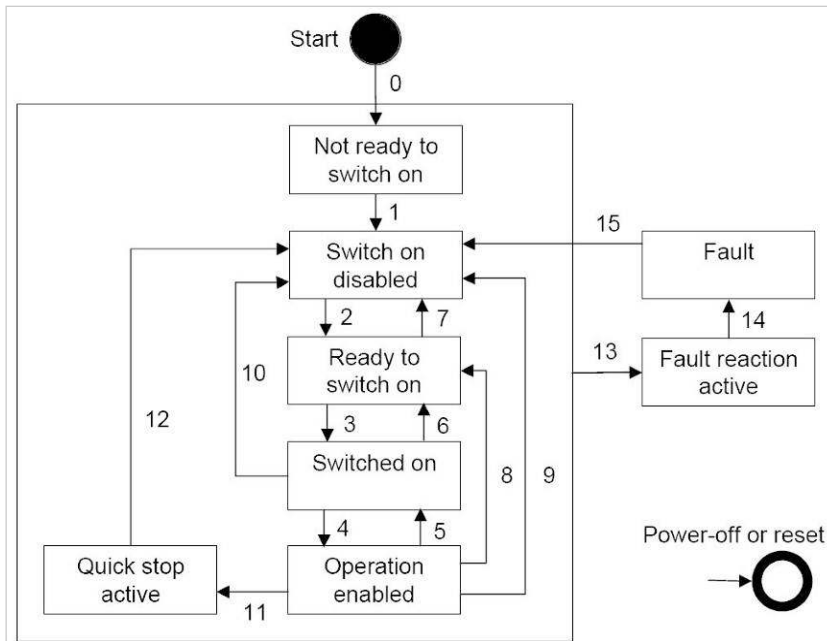

Figure 9. Power Drive System State Diagram

Notes:

Not Ready to Switch On	“Not ready to operate” received from the controller.
Switch On Disabled	Ready to operate. Can read and write parameters. Motion functionality cannot be executed.
Ready to Switch On	Ready to operate. Can read and write parameters. Motion functionality cannot be executed. Bus voltage must be switched on.
Operation Enabled	Drive power stage is enabled. No fault is present. Motion functionality can be executed.
Quick Stop Active	Drive was stopped using controlled stop. Power stage is enabled. Motion functionality cannot be executed.
Fault Reaction Active	A fault has occurred. Drive is in the process of ramping down to 0 velocity (Active Disable process).
Fault	A fault has occurred. Power stage is disabled.

Bits 0, 1, 2, 3, 5 and 6 of the parameter Statusword provide information on the operating state.

	Operating State	Bit 6: Switch On Disabled	Bit 5: Quick Stop	Bit 3: Fault	Bit 2: Operation Enabled	Bit 1: Switch On	Bit 0: Ready to Switch On
2	Not Ready To Switch On	0	X	0	0	0	0
3	Switch On Disabled	1	X	0	0	0	0
4	Ready To Switch On	0	1	0	0	0	1
5	Switched On	0	1	0	0	1	1
6	Operation Enabled	0	1	0	1	1	1
7	Quick Stop Active	0	0	0	1	1	1
8	Fault Reaction Active	0	X	1	1	1	1
9	Fault	0	X	1	0	0	0

The following table shows the bit coding of Statusword object 6041h.

Parameter Name	Bit Assignments	Data Type R/W
Statusword	Bits 0–3 = Status bits Bit 4 = Voltage enabled Bits 5–6 = Status bits Bit 7 = Warning Bit 8 = Reserved Bit 9 = Remote Bit 10 = Target reached Bit 11 = Internal limit is active Bit 12 = Operating mode-specific Bit 13 = Operating mode-specific Bit 14 = Manufacturer-specific Bit 15 = Manufacturer-specific	Unsigned16 Read only

Notes:

- Bit 4 Bit 4=1 indicates whether the DC bus voltage is correct. If the voltage is missing or is too low, the device does not transition from operating state 3 to operating state 4.
- Bit 7 If bit 7 (warning) of the status word is 1, it indicates the presence of a warning condition. Warning is not an error or fault (e.g., temperature limit exceeded, job refused). The status of the PDS FSA does not change. The cause of the warning may be given in the fault code parameter object (603Fh).
- Bit 9 If bit 9 is set, the device carries out commands via the fieldbus. If Bit 9 is reset, the device is controlled via a different interface. In such a case, it is still possible to read or write parameters via the fieldbus.
- Bit 10 Bit 10 is used for monitoring the current operating mode.
- Bit 12 Bit 12 is used for monitoring the current operating mode.
- Bit 13 Bit 13 only becomes 1 if an error needs to be resolved prior to further processing.

3.5 Changing the Operating State

The parameter Controlword can be used to switch between operating states.

Parameter Name	Bit Assignments	Data Type R/W
Controlword	Bit 0 = Switch On Bit 1 = Enable Voltage Bit 2 = Quick Stop Bit 3 = Enable Operation Bits 4–6 = Operating Mode specific Bit 7 = Fault Reset Bit 8 = Halt Bit 9 = Reserved Bits 10–15 = Reserved (must be 0) Changed settings become active immediately.	Unsigned16 Read only

The following table shows the bit coding of Controlword object 6040h.

Bits 0, 1, 2, 3 and 7 allow you to switch between the operating states.

Fieldbus Command	State Transitions	State Transition To	Bit 7: Fault Reset	Bit 3: Enable Operate	Bit 2: Quick Stop	Bit 1: Enable Voltage	Bit 0: Switch On
Shutdown	T2, T6, T8	4 – Ready To Switch On	X	X	1	1	0
Switch On	T3	5 – Switched On	X	X	1	1	1
Disable Voltage	T7, T9, T10, T12	3 – Switch On Disabled	X	X	X	0	X
Quick Stop	T7, T10 T11	3 – Switch On Disabled 7 – Quick Stop Active	X	X	0	1	X
Disable Operation	T5	5 – Switched On	X	0	1	1	1
Enable Operation	T4, T16	6 – Operation Enabled	X	1	1	1	1
Fault Reset	T15	3 – Switch On Disabled	0 » 1	X	X	X	X

Notes:

- Bit 4–6 Bits 4 to 6 are used for the operating mode-specific settings.
- Bit 8 A Halt can be triggered with bit 8=1.
- Bit 9–15 Reserved.

4 Mandatory Objects

Object 1000h – Device Type

Description	This object indicates the kind of device. The lower 16 bit contains the device profile number and the upper 16 bit contains additional information.
Object Type	Variable
Data Type	Unsigned32
Access	Constant
PDO Mapping	No
Default Value	0x00420192

Object 1001h – Error Register

Description	<p>This object has 8 bits, each for a certain error type. When an error occurs, the corresponding bit is set.</p> <p>Bit Meaning</p> <p>0 generic error</p> <p>1 current</p> <p>2 voltage</p> <p>3 temperature</p> <p>4 communication error (overrun, error state)</p> <p>5 device profile specific</p> <p>6 reserved</p> <p>7 manufacturer specific</p>
Object Type	Variable
Data Type	Unsigned8
Access	Read only
PDO Mapping	No
Default Value	0x00

Object 1018h – Identity

Description	This object contains the hardware version of the device.
Object Type	Record
Sub-indices	5

Sub-index	0
Description	Number of Entries
Object Type	Variable
Data Type	Unsigned8
Access	Read only
PDO Mapping	No
Default Value	0x4
Lower Limit	0x1
Upper Limit	0x4
Sub-index	1
Description	Vendor ID
Object Type	Variable
Data Type	Unsigned32
Access	Read only
PDO Mapping	No
Default Value	0x00000513 (STXI Motion Ltd. CAN vendor number)
Sub-index	2
Description	Product Code
Object Type	Variable
Data Type	Unsigned32
Access	Read only
PDO Mapping	No
Default Value	0x0
Sub-index	3
Description	Revision number
Object Type	Variable
Data Type	Unsigned32
Access	Read only
PDO Mapping	No
Sub-index	4
Description	Serial Number
Object Type	Variable
Data Type	Unsigned32
Access	Read only
PDO Mapping	No

5 Communication Objects

Object 1003h – Predefined Error Field

Description	This object provides the errors that occurred on the CANopen device and were signaled via the emergency object. In doing so it provides an error history. Writing 0 to sub-index 0 deletes the entire error history.
Object Type	Array
Sub-indices	11
Sub-index	0
Parameter Name	Number of Errors
Object Type	Variable
Data Type	Unsigned8
Access	Read/Write
PDO Mapping	No
Default Value	0x00000000
Sub-index	1
Parameter Name	Standard Error Field
Object Type	Variable
Data Type	Unsigned32
Access	Read only
PDO Mapping	No
Default Value	0x00000000
Sub-index	2
Parameter Name	Standard Error Field
Object Type	Variable
Data Type	Unsigned32
Access	Read only
PDO Mapping	No
Default Value	0x00000000
Sub-index	3
Parameter Name	Standard Error Field
Object Type	Variable
Data Type	Unsigned32
Access	Read only
PDO Mapping	No
Default Value	0x00000000

Sub-index	4
Parameter Name	Standard Error Field
Object Type	Variable
Data Type	Unsigned32
Access	Read only
PDO Mapping	No
Default Value	0x00000000
Sub-index	5
Parameter Name	Standard Error Field
Object Type	Variable
Data Type	Unsigned32
Access	Read only
PDO Mapping	No
Default Value	0x00000000
Sub-index	6
Parameter Name	Standard Error Field
Object Type	Variable
Data Type	Unsigned32
Access	Read only
PDO Mapping	No
Default Value	0x00000000
Sub-index	7
Parameter Name	Standard Error Field
Object Type	Variable
Data Type	Unsigned32
Access	Read only
PDO Mapping	No
Default Value	0x00000000
Sub-index	8
Parameter Name	Standard Error Field
Object Type	Variable
Data Type	Unsigned32
Access	Read only
PDO Mapping	No
Default Value	0x00000000

Sub-index	9
Parameter Name	Standard Error Field
Object Type	Variable
Data Type	Unsigned32
Access	Read only
PDO Mapping	No
Default Value	0x00000000
Sub-index	10
Parameter Name	Standard Error Field
Object Type	Variable
Data Type	Unsigned32
Access	Read only
PDO Mapping	No
Default Value	0x00000000

Object 1005h – COB-ID SYNC

Description	This object indicates the configured the COB-ID of the synchronization object (SYNC). It also defines whether the CANopen device generates the SYNC.
Object Type	Variable
Data Type	Unsigned32
Access	Read/Write
PDO Mapping	No
Default Value	0x00000080

Object 1006h – Communication Cycle Period

Description	This object provides the communication cycle period. This period defines the SYNC interval.
Object Type	Variable
Data Type	Unsigned32
Access	Read/Write
PDO Mapping	No
Default Value	0x00000000

Object 1008h – Manufacturer Device Name

Description	This object provides the name of the device as given by the manufacturer.
Object Type	Variable
Data Type	Visible string
Access	Constant
PDO Mapping	No

Object 1009h – Manufacturer Hardware Version

Description	This object provides the manufacturer hardware version description.
Object Type	Variable
Data Type	Visible string
Access	Constant
PDO Mapping	No

Object 100Ah – Manufacturer Software Version

Description	This object provides the manufacturer software version description.
Object Type	Variable
Data Type	Visible string
Access	Constant
PDO Mapping	No

Object 1010h – Store Parameter Field

Description	This object controls the saving of parameters in non-volatile memory.
Object Type	Array
Sub-indices	2
Sub-index	0
Parameter Name	Number of Entries
Object Type	Variable
Data Type	Unsigned8
Access	Read only
PDO Mapping	No
Default Value	0x01
Lower Limit	0x0
Upper Limit	0x7F

Sub-index	1
Parameter Name	Save All Parameters
Object Type	Variable
Data Type	Unsigned32
Access	Read/Write
PDO Mapping	No
ObjFlags	0x00000001

Object 1011h – Restore Default Parameters

Description	This object serves to restore the default values of parameters according to the communication profile, device profile, and application profile.
Object Type	Array
Sub-indices	2
Sub-index	0
Parameter Name	Number of Entries
Object Type	Variable
Data Type	Unsigned8
Access	Read only
PDO Mapping	No
Default Value	0x1
Sub-index	1
Parameter Name	Restore All Default Parameters
Object Type	Variable
Data Type	Unsigned32
Access	Read/Write
PDO Mapping	No
ObjFlags	0x00000001

Object 1014h – COB-ID EMCY

Description	This object indicates the configured COB-ID for the EMCY write service.
Object Type	Variable
Data Type	Unsigned32
Access	Read/Write
PDO Mapping	No
Default Value	\$NODEID+0x80

Object 1016h – Consumer Heartbeat Time

Description	The consumer heartbeat time provides the expected heartbeat cycle times. They are higher than the corresponding producer heartbeat times configured on the CANopen device producing this heartbeat. Monitoring starts after the reception of the first heartbeat.
Object Type	Array
Sub-indices	3
Sub-index	0
Description	Number of Entries
Object Type	Variable
Data Type	Unsigned8
Access	Read only
PDO Mapping	No
Default Value	0x02
Lower Limit	0x1
Upper Limit	0x7F
Sub-index	1
Description	Consumer Heartbeat Time 1
Object Type	Variable
Data Type	Unsigned32
Access	Read/Write
PDO Mapping	No
Default Value	0x00000000
Lower Limit	0x0
Upper Limit	0x02FFFFFF
Sub-index	2
Description	Consumer Heartbeat Time 2
Object Type	Variable
Data Type	Unsigned32
Access	Read/Write
PDO Mapping	No
Default Value	0x00000000
Lower Limit	0x0
Upper Limit	0x02FFFFFF

Object 1017h – Producer Heartbeat Time

Description	This object indicate the configured cycle time of the heartbeat
Object Type	Variable
Data Type	Unsigned16
Access	Read/Write
PDO Mapping	No
Default Value	0x00000000

Object 1400h – Receive PDO Communication Parameter 1

Description	This object contains the communication parameters of the current PDO the device is able to receive.
Object Type	Record
Sub-indices	4
Sub-index	0
Description	Number of Entries
Object Type	Variable
Data Type	Unsigned8
Access	Read only
PDO Mapping	No
Default Value	0x03
Lower Limit	0x02
Upper Limit	0x05
Sub-index	1
Description	COB-ID
Object Type	Variable
Data Type	Unsigned32
Access	Read/Write
PDO Mapping	No
Default Value	\$NODEID+0x200
Lower Limit	\$NODEID+0x1
Upper Limit	\$NODEID+0xFFFFFFFF

Sub-index	2
Description	Transmission Type
Object Type	Variable
Data Type	Unsigned8
Access	Read/Write
PDO Mapping	No
Default Value	0xFF
Lower Limit	0x00
Upper Limit	0xFF
Sub-index	3
Description	Inhibit Time
Object Type	Variable
Data Type	Unsigned16
Access	Read/Write
PDO Mapping	No
Default Value	0x0
Lower Limit	0x0000
Upper Limit	0xFFFF

Object 1401h – Receive PDO Communication Parameter 2

Description	This object contains the communication parameters of the current PDO the device is able to receive.
Object Type	Record
Sub-indices	4
Sub-index	0
Description	Number of Entries
Object Type	Variable
Data Type	Unsigned8
Access	Read only
PDO Mapping	No
Default Value	0x03
Lower Limit	0x02
Upper Limit	0x05

Sub-index	1
Description	COB-ID
Object Type	Variable
Data Type	Unsigned32
Access	Read/Write
PDO Mapping	No
Default Value	\$NODEID+0x300
Lower Limit	\$NODEID+0x1
Upper Limit	\$NODEID+0xFFFFFFFF
Sub-index	2
Description	Transmission Type
Object Type	Variable
Data Type	Unsigned8
Access	Read/Write
PDO Mapping	No
Default Value	0x1
Lower Limit	0x00
Upper Limit	0xFF
Sub-index	3
Description	Inhibit Time
Object Type	Variable
Data Type	Unsigned16
Access	Read/Write
PDO Mapping	No
Default Value	0x0
Lower Limit	0x0000
Upper Limit	0xFFFF

Object 1402h – Receive PDO Communication Parameter 3

Description	This object contains the communication parameters of the current PDO the device is able to receive.
Object Type	Record
Sub-indices	4

Sub-index	0
Description	Number of Entries
Object Type	Variable
Data Type	Unsigned8
Access	Read only
PDO Mapping	No
Default Value	0x03
Lower Limit	0x02
Upper Limit	0x05
Sub-index	1
Description	COB-ID
Object Type	Variable
Data Type	Unsigned32
Access	Read/Write
PDO Mapping	No
Default Value	\$NODEID+0x400
Lower Limit	\$NODEID+0x1
Upper Limit	\$NODEID+0xFFFFFFFF
Sub-index	2
Description	Transmission Type
Object Type	Variable
Data Type	Unsigned8
Access	Read/Write
PDO Mapping	No
Default Value	0x1
Lower Limit	0x00
Upper Limit	0xFF
Sub-index	3
Description	Inhibit Time
Object Type	Variable
Data Type	Unsigned16
Access	Read/Write
PDO Mapping	No
Default Value	0x0
Lower Limit	0x0000
Upper Limit	0xFFFF

Object 1403h – Receive PDO Communication Parameter 4

Description	This object contains the communication parameters of the current PDO the device is able to receive.
Object Type	Record
Sub-indices	4
Sub-index	0
Description	Number of Entries
Object Type	Variable
Data Type	Unsigned8
Access	Read only
PDO Mapping	No
Default Value	0x03
Lower Limit	0x02
Upper Limit	0x05
Sub-index	1
Description	COB-ID
Object Type	Variable
Data Type	Unsigned32
Access	Read/Write
PDO Mapping	No
Default Value	\$NODEID+0x500
Lower Limit	\$NODEID+0x1
Upper Limit	\$NODEID+0xFFFFFFFF
Sub-index	2
Description	Transmission Type
Object Type	Variable
Data Type	Unsigned8
Access	Read/Write
PDO Mapping	No
Default Value	0x1
Lower Limit	0x00
Upper Limit	0xFF

Sub-index	3
Description	Inhibit Time
Object Type	Variable
Data Type	Unsigned16
Access	Read/Write
PDO Mapping	No
Default Value	0x0
Lower Limit	0x0000
Upper Limit	0xFFFF

Object 1600h – Receive PDO Mapping Parameter 1

Description	This object contains the mapping parameters for the PDOs the CANopen device is able to receive.
Object Type	Record
Sub-indices	3
Sub-index	0
Description	Number of Entries
Object Type	Variable
Data Type	Unsigned8
Access	Read/Write
PDO Mapping	No
Default Value	0x2
Lower Limit	0x0
Upper Limit	0x40
Sub-index	1
Description	Mapping Entry 1
Object Type	Variable
Data Type	Unsigned32
Access	Read/Write
PDO Mapping	No
Default Value	0x60400010
Lower Limit	0x0
Upper Limit	0xFFFFFFFF

Sub-index	2
Description	Mapping Entry 2
Object Type	Variable
Data Type	Unsigned32
Access	Read/Write
PDO Mapping	No
Default Value	0x60600008
Lower Limit	–
Upper Limit	–

Object 1601h – Receive PDO Mapping Parameter 2

Description	This object contains the mapping parameters for the PDOs the CANopen device is able to receive.
Object Type	Record
Sub-indices	2
Sub-index	0
Description	Number of Entries
Object Type	Variable
Data Type	Unsigned8
Access	Read/Write
PDO Mapping	No
Default Value	0x1
Lower Limit	0x0
Upper Limit	0xFF
Sub-index	1
Description	Mapping Entry 1
Object Type	Variable
Data Type	Unsigned32
Access	Read/Write
PDO Mapping	No
Default Value	0x60800020
Lower Limit	0x0
Upper Limit	0xFFFFFFFF

Object 1602h – Receive PDO Mapping Parameter 3

Description	This object contains the mapping parameters for the PDOs the CANopen device is able to receive.
Object Type	Record
Sub-indices	2
Sub-index	0
Description	Number of Entries
Object Type	Variable
Data Type	Unsigned8
Access	Read/Write
PDO Mapping	No
Default Value	0x1
Lower Limit	0x0
Upper Limit	0xFF
Sub-index	1
Description	Mapping Entry 1
Object Type	Variable
Data Type	Unsigned32
Access	Read/Write
PDO Mapping	No
Default Value	0x60FF0020
Lower Limit	0x0
Upper Limit	0xFFFFFFFF

Object 1603h – Receive PDO Mapping Parameter 4

Description	This object contains the mapping parameters for the PDOs the CANopen device is able to receive.
Object Type	Record
Sub-indices	1
Sub-index	0
Description	Number of Entries
Object Type	Variable
Data Type	Unsigned8
Access	Read/Write
PDO Mapping	No
Default Value	0x0
Lower Limit	0x0
Upper Limit	0xFF

Object 1800h – Transmit PDO Communication Parameter 1

Description	This object contains the communication parameters of the current PDO the device is able to transmit.
Object Type	Record
Sub-indices	6
Sub-index	0
Description	Number of Entries
Object Type	Variable
Data Type	Unsigned8
Access	Read/Write
PDO Mapping	No
Default Value	0x05
Lower Limit	0x02
Upper Limit	0x06
Sub-index	1
Description	COB-ID
Object Type	Variable
Data Type	Unsigned32
Access	Read/Write
PDO Mapping	No
Default Value	\$NODEID+0x180
Lower Limit	\$NODEID+0x1
Upper Limit	\$NODEID+0xFFFFFFFF
Sub-index	2
Description	Transmission Type
Object Type	Variable
Data Type	Unsigned8
Access	Read/Write
PDO Mapping	No
Default Value	0x1
Lower Limit	0x00
Upper Limit	0xFF

Sub-index	3
Description	Inhibit Time
Object Type	Variable
Data Type	Unsigned16
Access	Read/Write
PDO Mapping	No
Default Value	0x0
Lower Limit	0x0000
Upper Limit	0xFFFF
Sub-index	4
Description	Compatibility Entry
Object Type	Variable
Data Type	Unsigned8
Access	Read/Write
PDO Mapping	No
Default Value	0x0
Lower Limit	0x00
Upper Limit	0xFF
Sub-index	5
Description	Event Timer
Object Type	Variable
Data Type	Unsigned16
Access	Read/Write
PDO Mapping	No
Default Value	0x0
Lower Limit	0x0
Upper Limit	0xFF

Object 1801h – Transmit PDO Communication Parameter 2

Description	This object contains the communication parameters of the current PDO the device is able to transmit.
Object Type	Record
Sub-indices	6

Sub-index	0
Description	Number of Entries
Object Type	Variable
Data Type	Unsigned8
Access	Read/Write
PDO Mapping	No
Default Value	0x05
Lower Limit	0x02
Upper Limit	0x06
Sub-index	1
Description	COB-ID
Object Type	Variable
Data Type	Unsigned32
Access	Read/Write
PDO Mapping	No
Default Value	\$NODEID+0x280
Lower Limit	\$NODEID+0x1
Upper Limit	\$NODEID+0xFFFFFFFF
Sub-index	2
Description	Transmission Type
Object Type	Variable
Data Type	Unsigned8
Access	Read/Write
PDO Mapping	No
Default Value	0x1
Lower Limit	0x00
Upper Limit	0xFF
Sub-index	3
Description	Inhibit Time
Object Type	Variable
Data Type	Unsigned16
Access	Read/Write
PDO Mapping	No
Default Value	0x0
Lower Limit	0x0000
Upper Limit	0xFFFF

Sub-index	4
Description	Compatibility Entry
Object Type	Variable
Data Type	Unsigned8
Access	Read/Write
PDO Mapping	No
Default Value	0x0
Lower Limit	0x00
Upper Limit	0xFF
Sub-index	5
Description	Event Timer
Object Type	Variable
Data Type	Unsigned16
Access	Read/Write
PDO Mapping	No
Default Value	0x0
Lower Limit	0x0
Upper Limit	0xFFFF

Object 1802h – Transmit PDO Communication Parameter 3

Description	This object contains the communication parameters of the current PDO the device is able to transmit.
Object Type	Record
Sub-indices	6
Sub-index	0
Description	Number of Entries
Object Type	Variable
Data Type	Unsigned8
Access	Read/Write
PDO Mapping	No
Default Value	0x05
Lower Limit	0x02
Upper Limit	0x06

Sub-index	1
Description	COB-ID
Object Type	Variable
Data Type	Unsigned32
Access	Read/Write
PDO Mapping	No
Default Value	\$NODEID+0x380
Lower Limit	\$NODEID+0x1
Upper Limit	\$NODEID+0xFFFFFFFF
Sub-index	2
Description	Transmission Type
Object Type	Variable
Data Type	Unsigned8
Access	Read/Write
PDO Mapping	No
Default Value	0x1
Lower Limit	0x00
Upper Limit	0xFF
Sub-index	3
Description	Inhibit Time
Object Type	Variable
Data Type	Unsigned16
Access	Read/Write
PDO Mapping	No
Default Value	0x0
Lower Limit	0x0000
Upper Limit	0xFFFF
Sub-index	4
Description	Compatibility Entry
Object Type	Variable
Data Type	Unsigned8
Access	Read/Write
PDO Mapping	No
Default Value	0x0
Lower Limit	0x00
Upper Limit	0xFF

Sub-index	5
Description	Event Timer
Object Type	Variable
Data Type	Unsigned16
Access	Read/Write
PDO Mapping	No
Default Value	0x0
Lower Limit	0x0
Upper Limit	0xFFFF

Object 1803h – Transmit PDO Communication Parameter 4

Description	This object contains the communication parameters of the current PDO the device is able to transmit.
Object Type	Record
Sub-indices	6
Sub-index	0
Description	Number of Entries
Object Type	Variable
Data Type	Unsigned8
Access	Read/Write
PDO Mapping	No
Default Value	0x05
Lower Limit	0x02
Upper Limit	0x06
Sub-index	1
Description	COB-ID
Object Type	Variable
Data Type	Unsigned32
Access	Read/Write
PDO Mapping	No
Default Value	\$NODEID+0x480
Lower Limit	\$NODEID+0x1
Upper Limit	\$NODEID+0xFFFFFFFF

Sub-index	2
Description	Transmission Type
Object Type	Variable
Data Type	Unsigned8
Access	Read/Write
PDO Mapping	No
Default Value	0x1
Lower Limit	0x00
Upper Limit	0xFF
Sub-index	3
Description	Inhibit Time
Object Type	Variable
Data Type	Unsigned16
Access	Read/Write
PDO Mapping	No
Default Value	0x0
Lower Limit	0x0000
Upper Limit	0xFFFF
Sub-index	4
Description	Compatibility Entry
Object Type	Variable
Data Type	Unsigned8
Access	Read/Write
PDO Mapping	No
Default Value	0x0
Lower Limit	0x00
Upper Limit	0xFF
Sub-index	5
Description	Event Timer
Object Type	Variable
Data Type	Unsigned16
Access	Read/Write
PDO Mapping	No
Default Value	0x0
Lower Limit	0x0
Upper Limit	0xFFFF

Object 1A00h – Transmit PDO Mapping Parameter 1

Description	This object contains the mapping parameters of the current PDO the device is able to transmit.
Object Type	Record
Sub-indices	3
Sub-index	0
Description	Number of Entries
Object Type	Variable
Data Type	Unsigned8
Access	Read/Write
PDO Mapping	No
Default Value	0x2
Lower Limit	0x0
Upper Limit	0xFF
Sub-index	1
Description	Mapping Entry 1
Object Type	Variable
Data Type	Unsigned32
Access	Read/Write
PDO Mapping	No
Default Value	0x60410010
Lower Limit	–
Upper Limit	–
Sub-index	2
Description	Mapping Entry 2
Object Type	Variable
Data Type	Unsigned32
Access	Read/Write
PDO Mapping	No
Default Value	0x60610008
Lower Limit	–
Upper Limit	–

Object 1A01h – Transmit PDO Mapping Parameter 2

Description	This object contains the mapping parameters of the current PDO the device is able to transmit.
Object Type	Record
Sub-indices	2

Sub-index	0
Description	Number of Entries
Object Type	Variable
Data Type	Unsigned8
Access	Read/Write
PDO Mapping	No
Default Value	0x1
Lower Limit	0x0
Upper Limit	0xFF
Sub-index	1
Description	Mapping Entry 1
Object Type	Variable
Data Type	Unsigned32
Access	Read/Write
PDO Mapping	No
Default Value	0x606C0020
Lower Limit	0x0
Upper Limit	0xFFFFFFFF

Object 1A02h – Transmit PDO Mapping Parameter 3

Description	This object contains the mapping parameters of the current PDO the device is able to transmit.
Object Type	Record
Sub-indices	2
Sub-index	0
Description	Number of Entries
Object Type	Variable
Data Type	Unsigned8
Access	Read/Write
PDO Mapping	No
Default Value	0x1
Lower Limit	0x0
Upper Limit	0xFF

Sub-index	1
Description	Mapping Entry 1
Object Type	Variable
Data Type	Unsigned32
Access	Read/Write
PDO Mapping	No
Lower Limit	0x0
Default Value	0x60780010
Upper Limit	0xFFFFFFFF

Object 1A03h – Transmit PDO Mapping Parameter 4

Description	This object contains the mapping parameters of the current PDO the device is able to transmit.
Object Type	Record
Sub-indices	1
Sub-index	0
Description	Number of Entries
Object Type	Variable
Data Type	Unsigned8
Access	Read/Write
PDO Mapping	No
Default Value	0x0
Lower Limit	0x0
Upper Limit	0xFF

6 Manufacturer Specific Objects

Object 20F0h – NMT After Boot

Description	State of the CANopen device (node) after boot. If object=0, the device enters Pre-operational state. If object= 1 (or any other value), device directly enters Operational state.
Object Type	Variable
Data Type	Unsigned8
Access	Read/Write
PDO Mapping	No
Default Value	0x0
Lower Limit	0x0
Upper Limit	0x1

Object 2100h – Error Code

Description	Global error code of failed parameter excess.
Object Type	Array
Sub-indices	2
Sub-index	0
Description	Number of Entries
Object Type	Variable
Data Type	Unsigned8
Access	Read only
PDO Mapping	No
Default Value	0x1
Lower Limit	0x00
Upper Limit	0xFF
Sub-index	1
Description	Last Command Error
Object Type	Variable
Data Type	Unsigned32
Access	Read only
PDO Mapping	No
Default Value	0x0
Lower Limit	0x00000000
Upper Limit	0xFFFFFFFF

Object 2101h – Enable Drive

Description	This object enables and disables the drive, and stops motion.
Object Type	Array
Sub-indices	4
Sub-index	0
Description	Number of Entries
Object Type	Variable
Data Type	Unsigned8
Access	Read only
PDO Mapping	No
Default Value	0x3
Lower Limit	0x00
Upper Limit	0xFF
Sub-index	1
Description	Motor Enable
Object Type	Variable
Data Type	Unsigned32
Access	Read/Write
PDO Mapping	No
Default Value	–
Lower Limit	0x0
Upper Limit	0x1
ObjFlags	0x00000001
Sub-index	2
Description	Stop Motion
Object Type	Variable
Data Type	Unsigned32
Access	Read/Write
PDO Mapping	No
Default Value	–
Lower Limit	0x0
Upper Limit	0x1
ObjFlags	0x00000001

Sub-index	3
Description	Enable Gate Driver
Object Type	Variable
Data Type	Unsigned32
Access	Read/Write
PDO Mapping	No
Default Value	–
Lower Limit	0x0
Upper Limit	0x1
ObjFlags	0x00000001

Object 2103h – Current Command

Description	This object indicates the current command.
Object Type	Array
Sub-indices	2
Sub-index	0
Description	Number of Entries
Object Type	Variable
Data Type	Unsigned8
Access	Read only
PDO Mapping	No
Default Value	0x1
Lower Limit	0x00
Upper Limit	0xFF
Sub-index	1
Description	Current [A]
Object Type	Variable
Data Type	Real32
Access	Read/Write
PDO Mapping	No
Default Value	0.0
ObjFlags	0x00000001

Object 2104h – Speed Command

Description	This object indicates the speed loop parameters.
Object Type	Array
Sub-indices	3

Sub-index	0
Description	Number of Entries
Object Type	Variable
Data Type	Unsigned8
Access	Read only
PDO Mapping	No
Default Value	11 (0x0B)
Lower Limit	0x00
Upper Limit	0xFF
Sub-index	1
Description	Speed [counts/second]
Object Type	Variable
Data Type	Integer32
Access	Read/Write
PDO Mapping	No
Default Value	0x0
Lower Limit	0x80000000
Upper Limit	0x7FFFFFFF
ObjFlags	0x00000001
Sub-index	11
Description	Speed [rpm]
Object Type	Variable
Data Type	Integer32
Access	Read/Write
PDO Mapping	No
Default Value	0x0
Lower Limit	0x80000000
Upper Limit	0x7FFFFFFF
ObjFlags	0x00000001

Object 2105h – Position Command

Description	This object indicates the position command.
Object Type	Array
Sub-indices	4

Sub-index	0
Description	Number of Entries
Object Type	Variable
Data Type	Unsigned8
Access	Read only
PDO Mapping	No
Default Value	0x3
Lower Limit	0x00
Upper Limit	0xFF
Sub-index	1
Description	Position Absolute [counts]
Object Type	Variable
Data Type	Integer32
Access	Read/Write
PDO Mapping	No
Default Value	0x0
Lower Limit	0x80000000
Upper Limit	0x7FFFFFFF
ObjFlags	0x00000001
Sub-index	2
Description	Position Relative [counts]
Object Type	Variable
Data Type	Integer32
Access	Read/Write
PDO Mapping	No
Default Value	0x0
Lower Limit	0x80000000
Upper Limit	0x7FFFFFFF
ObjFlags	0x00000001

Sub-index	3
Description	Speed Position [counts/second]
Object Type	Variable
Data Type	Integer32
Access	Read/Write
PDO Mapping	No
Default Value	0x0
Lower Limit	0x80000000
Upper Limit	0x7FFFFFFF
ObjFlags	0x00000001

Object 2106h – Calibration

Description	This object starts the calibration process.
Object Type	Record
Sub-indices	18
Sub-index	0
Description	Number of Entries
Object Type	Variable
Data Type	Unsigned8
Access	Read only
PDO Mapping	No
Default Value	0x15
Lower Limit	0x00
Upper Limit	0xFF
Sub-index	2
Description	Current Offset Calibration
Object Type	Variable
Data Type	Integer32
Access	Read/Write
PDO Mapping	No
Default Value	0x00
Lower Limit	0x00
Upper Limit	0x01
ObjFlags	0x00000001

Sub-index	3
Description	Current Offset Calibration Status
Object Type	Variable
Data Type	Integer32
Access	Read only
PDO Mapping	No
Default Value	0x00
Lower Limit	0x00
Upper Limit	0x38
Sub-index	4
Description	PI Current Loop Calibration
Object Type	Variable
Data Type	Integer32
Access	Read/Write
PDO Mapping	No
Default Value	0x0
Lower Limit	0x0
Upper Limit	0x1
ObjFlags	0x00000001
Sub-index	5
Description	PI Current Loop Calibration Status
Object Type	Variable
Data Type	Integer32
Access	Read only
PDO Mapping	No
Default Value	0x0
Lower Limit	0x00
Upper Limit	0x05

Sub-index	6
Description	Hall Mapping Calibration
Object Type	Variable
Data Type	Integer32
Access	Read/Write
PDO Mapping	No
Default Value	0x0
Lower Limit	0x0
Upper Limit	0x1
ObjFlags	0x00000001
Sub-index	7
Description	Hall Mapping Calibration Status
Object Type	Variable
Data Type	Integer32
Access	Read only
PDO Mapping	No
Default Value	x00
Lower Limit	0x00
Upper Limit	0x03
Sub-index	8
Description	Feedback Direction Calibration
Object Type	Variable
Data Type	Integer32
Access	Read/Write
PDO Mapping	No
Default Value	0x0
Lower Limit	0x0
Upper Limit	0x0
ObjFlags	0x00000001

Sub-index	9
Description	Feedback Direction Calibration Status
Object Type	Variable
Data Type	Integer32
Access	Read only
PDO Mapping	No
Default Value	0x00
Lower Limit	0xFFFFFFFF
Upper Limit	0x03
Sub-index	10
Description	PI Speed Loop Calibration
Object Type	Variable
Data Type	Integer32
Access	Read/Write
PDO Mapping	No
Default Value	0x0
Lower Limit	0x0
Upper Limit	0x1
ObjFlags	0x00000001
Sub-index	11
Description	PI Speed Loop Calibration Status
Object Type	Variable
Data Type	Integer32
Access	Read only
PDO Mapping	No
Default Value	0x00
Lower Limit	0x00
Upper Limit	0x05

Sub-index	12
Description	PI Position Loop Calibration
Object Type	Variable
Data Type	Integer32
Access	Read/Write
PDO Mapping	No
Default Value	0x0
Lower Limit	0x0
Upper Limit	0x1
ObjFlags	0x00000001
Sub-index	13
Description	PI Position Loop Calibration Status
Object Type	Variable
Data Type	Integer32
Access	Read only
PDO Mapping	No
Default Value	0x00
Lower Limit	0x00
Upper Limit	0x05
Sub-index	14
Description	Absolute Encoder Electrical Angle
Object Type	Variable
Data Type	Integer32
Access	Read/Write
PDO Mapping	No
Default Value	0x0
Lower Limit	0x0
Upper Limit	0x1
ObjFlags	0x00000001

Sub-index	15
Description	Absolute Encoder Electrical Angle Status
Object Type	Variable
Data Type	Integer32
Access	Read only
PDO Mapping	No
Default Value	0x00
Lower Limit	0x00
Upper Limit	0x03
Sub-index	16
Description	Bode Operation
Object Type	Variable
Data Type	Integer32
Access	Read/Write
PDO Mapping	No
Default Value	0x0
Lower Limit	0x0
Upper Limit	0x1
ObjFlags	0x00000001
Sub-index	20
Description	Analog Offset Calibration
Object Type	Variable
Data Type	Integer32
Access	Read/Write
PDO Mapping	No
Default Value	0x0
Lower Limit	0x0
Upper Limit	0x1
ObjFlags	0x00000001

Sub-index	21
Description	Analog Offset Calibration Status
Object Type	Variable
Data Type	Integer32
Access	Read only
PDO Mapping	No
Default Value	0x1
Lower Limit	0x01
Upper Limit	0x03
ObjFlags	0x00000001

Object 2107h – Signal Generator Command

Description	Signal Generator Command
Object Type	Record
Sub-indices	8
Sub-index	0
Description	Number of entries
Object Type	Variable
Data Type	Unsigned 8
Access	Read only
PDO Mapping	No
Default Value	0x07
Lower Limit	0x00
Upper Limit	0xFF
Sub-index	1
Description	TBD
Object Type	Variable
Data Type	Integer32
Access	Read only
PDO Mapping	No
Default Value	–
Lower Limit	–
Upper Limit	–
ObjFlags	0x00000002

Sub-index	2
Description	Type
Object Type	Variable
Data Type	Unsigned32
Access	Read/Write
PDO Mapping	No
Default Value	0x0004
Lower Limit	0x0001
Upper Limit	0x0004
ObjFlags	0x00000001
Sub-index	3
Description	Period
Object Type	Variable
Data Type	Integer32
Access	Read only
PDO Mapping	No
Default Value	–
Lower Limit	–
Upper Limit	–
ObjFlags	0x00000002
Sub-index	4
Description	Count
Object Type	Variable
Data Type	Integer32
Access	Read only
PDO Mapping	No
Default Value	–
Lower Limit	–
Upper Limit	–
ObjFlags	0x00000002

Sub-index	5
Description	Amplitude
Object Type	Variable
Data Type	Integer32
Access	Read only
PDO Mapping	No
Default Value	–
Lower Limit	–
Upper Limit	–
ObjFlags	0x00000002
Sub-index	6
Description	Offset
Object Type	Variable
Data Type	Real32
Access	Real/Write
PDO Mapping	No
Default Value	0.0
Lower Limit	–
Upper Limit	–
ObjFlags	0x00000001
Sub-index	7
Description	Frequency [Hz]
Object Type	Variable
Data Type	Real32
Access	Real/Write
PDO Mapping	No
Default Value	0.0
Lower Limit	–
Upper Limit	–
ObjFlags	0x00000001

Object 210Ch – Brake

Description	Brake
Object Type	Array
Sub-indices	2
Sub-index	0
Description	Number of Entries
Object Type	Variable
Data Type	Unsigned8
Access	Read only
PDO Mapping	No
Default Value	0x2
Lower Limit	0x00
Upper Limit	0xFF
Sub-index	2
Description	Power Out
Object Type	Variable
Data Type	Unsigned32
Access	Read/Write
PDO Mapping	No
Default Value	0x0
Lower Limit	0x0
Upper Limit	0x1
ObjFlags	0x00000001

Object 210Fh – Bode Plot Configuration

Description	Bode plot configuration.
Object Type	Record
Sub-indices	8
Sub-index	0
Description	Number of Entries
Object Type	Variable
Data Type	Unsigned8
Access	Read only
PDO Mapping	No
Default Value	0x7
Lower Limit	0x00
Upper Limit	0xFF

Sub-index	1
Description	TBD
Object Type	Variable
Data Type	Integer32
Access	Read only
PDO Mapping	No
Default Value	–
Lower Limit	–
Upper Limit	–
ObjFlags	0x00000002
Sub-index	2
Description	Control Loop
Object Type	Variable
Data Type	Unsigned32
Access	Read/Write
PDO Mapping	No
Default Value	0x00
Lower Limit	0x00
Upper Limit	0x06
Sub-index	3
Description	Frequency Start [Hz]
Object Type	Variable
Data Type	Real32
Access	Read/Write
PDO Mapping	No
Default Value	0.0
Lower Limit	–
Upper Limit	–
Sub-index	4
Description	Frequency End [Hz]
Object Type	Variable
Data Type	Real32
Access	Read/Write
PDO Mapping	No
Default Value	0.0
Lower Limit	–
Upper Limit	–

Sub-index	5
Description	Amplitude
Object Type	Variable
Data Type	Real32
Access	Read/Write
PDO Mapping	No
Default Value	0.0
Lower Limit	–
Upper Limit	–
Sub-index	6
Description	Number of Points per Decade (Resolution)
Object Type	Variable
Data Type	Unsigned32
Access	Read/Write
PDO Mapping	No
Default Value	0x0000
Lower Limit	0x0000
Upper Limit	0xFF
Sub-index	7
Description	Bode Feedback, Current, Speed or Position
Object Type	Variable
Data Type	Unsigned32
Access	Read/Write
PDO Mapping	No
Default Value	0x0000
Lower Limit	0x0000
Upper Limit	0x0002

Object 2110h – Digital Inputs Mode

Description	This object defines the input mode for inputs 1–4: 0 = Idle 1 = Positive Hardware Limit Switch 2 = Negative Hardware Limit Switch 3 = Home Switch 4 = Clear Fault Switch
Object Type	Array
Sub-indices	5

Sub-index	0
Description	Number of entries
Object Type	Variable
Data Type	Unsigned8
Access	Read only
PDO Mapping	No
Default Value	0x04
Lower Limit	0x00
Upper Limit	0xFF
Sub-index	1
Description	Functionality of Input Number 1
Object Type	Variable
Data Type	Unsigned32
Access	Read/Write
PDO Mapping	No
Default Value	0x00
Lower Limit	0x00
Upper Limit	0x04
Sub-index	2
Description	Functionality of Input Number 2
Object Type	Variable
Data Type	Unsigned32
Access	Read/Write
PDO Mapping	No
Default Value	0x00
Lower Limit	0x00
Upper Limit	0x04
Sub-index	3
Description	Functionality of Input Number 3
Object Type	Variable
Data Type	Unsigned32
Access	Read/Write
PDO Mapping	No
Default Value	0x00
Lower Limit	0x00
Upper Limit	0x04

Sub-index	4
Description	Functionality of Input Number 4
Object Type	Variable
Data Type	Unsigned32
Access	Read/Write
PDO Mapping	No
Default Value	0x00
Lower Limit	0x00
Upper Limit	0x04

Object 2111h – Digital Inputs Polarity

Description	This object sets the polarity of each digital input. 0 = Input is not inverted 1 = Input is inverted
Object Type	Array
Sub-indices	5
Sub-index	0
Description	Number of entries
Object Type	Variable
Data Type	Unsigned8
Access	Read only
PDO Mapping	No
Default Value	0x04
Lower Limit	0x00
Upper Limit	0xFF
Sub-index	1
Description	Polarity of Input Number 1
Object Type	Variable
Data Type	Unsigned32
Access	Read/Write
PDO Mapping	No
Default Value	0x0
Lower Limit	0x0
Upper Limit	0x1

Sub-index	2
Description	Polarity of Input Number 2
Object Type	Variable
Data Type	Unsigned32
Access	Read/Write
PDO Mapping	No
Default Value	0x0
Lower Limit	0x0
Upper Limit	0x1
Sub-index	3
Description	Polarity of Input Number 3
Object Type	Variable
Data Type	Unsigned32
Access	Read/Write
PDO Mapping	No
Default Value	0x0
Lower Limit	0x0
Upper Limit	0x1
Sub-index	4
Description	Polarity of Input Number 4
Object Type	Variable
Data Type	Unsigned32
Access	Read/Write
PDO Mapping	No
Default Value	0x0
Lower Limit	0x0
Upper Limit	0x1

Object 2118h – Commutation Feedback

Description	Commutation feedback angle
Object Type	Array
Sub-indices	2

Sub-index	0
Description	Number of Entries
Object Type	Variable
Data Type	Unsigned8
Access	Read only
PDO Mapping	No
Default Value	0x01
Lower Limit	0x00
Upper Limit	0xFF
Sub-index	1
Description	Commutation Angle [degrees]
Object Type	Variable
Data Type	Real32
Access	Read only
PDO Mapping	No
Default Value	0.0
Lower Limit	–
Upper Limit	–

Object 2119h – Speed Feedback

Description	Speed feedback
Object Type	Array
Sub-indices	3
Sub-index	0
Description	Number of Entries
Object Type	Variable
Data Type	Unsigned8
Access	Read only
PDO Mapping	No
Default Value	0x0B
Lower Limit	0x00
Upper Limit	0xFF

Sub-index	1
Description	Speed Feedback [encoder counts per second]
Object Type	Variable
Data Type	Integer32
Access	Read only
PDO Mapping	No
Default Value	0x0
Lower Limit	0x80000000
Upper Limit	0x7FFFFFFF
Sub-index	11
Description	Actual Velocity [rpm]
Object Type	Variable
Data Type	Integer32
Access	Read only
PDO Mapping	No
Default Value	0x0
Lower Limit	0x80000000
Upper Limit	0x7FFFFFFF

Object 211Ah – Position Feedback

Description	Position Feedback (Position Command)
Object Type	Array
Sub-indices	10
Sub-index	0
Description	Number of Entries
Object Type	Variable
Data Type	Unsigned8
Access	Read only
PDO Mapping	No
Default Value	0x09
Lower Limit	0x00
Upper Limit	0xFF

Sub-index	1
Description	Actual Position of the Drive [encoder counts] (Main)
Object Type	Variable
Data Type	Integer32
Access	Read only
PDO Mapping	No
Default Value	0x0
Lower Limit	0x80000000
Upper Limit	0x7FFFFFFF
Sub-index	2
Description	Actual Position Generated from the Hall Signals [counts] (Hall)
Object Type	Variable
Data Type	Integer32
Access	Read only
PDO Mapping	No
Default Value	0x0
Lower Limit	0x80000000
Upper Limit	0x7FFFFFFF
Sub-index	3
Description	Actual Position Generated from the Motor Feedback [counts] (Motor)
Object Type	Variable
Data Type	Integer32
Access	Read only
PDO Mapping	No
Default Value	0x0
Lower Limit	0x80000000
Upper Limit	0x7FFFFFFF

Sub-index	4
Description	External Actual Position Generated from the External Feedback [counts]
Object Type	Variable
Data Type	Integer32
Access	Read only
PDO Mapping	No
Default Value	0x0
Lower Limit	0x80000000
Upper Limit	0x7FFFFFFF
Sub-index	5
Description	Motor Feedback Index (zero pulse) Counter
Object Type	Variable
Data Type	Integer32
Access	Read only
PDO Mapping	No
Default Value	0x0
Lower Limit	0x80000000
Upper Limit	0x7FFFFFFF
Sub-index	6
Description	External Feedback Index (zero pulse) Counter
Object Type	Variable
Data Type	Integer32
Access	Read only
PDO Mapping	No
Default Value	0x0
Lower Limit	0x80000000
Upper Limit	0x7FFFFFFF
Sub-index	7
Description	Hall Raw Counter
Object Type	Variable
Data Type	Integer32
Access	Read only
PDO Mapping	No
Default Value	0x0
Lower Limit	0x80000000
Upper Limit	0x7FFFFFFF

Sub-index	8
Description	Motor Feedback Raw Counter
Object Type	Variable
Data Type	Integer32
Access	Read only
PDO Mapping	No
Default Value	0x0
Lower Limit	0x80000000
Upper Limit	0x7FFFFFFF
Sub-index	9
Description	External Feedback Raw Counter
Object Type	Variable
Data Type	Integer32
Access	Read only
PDO Mapping	No
Default Value	0x0
Lower Limit	0x80000000
Upper Limit	0x7FFFFFFF

Object 211Dh – Digital I/O Status

Description	Indicates the status of digital inputs and outputs.
Object Type	Array
Sub-indices	6
Sub-index	0
Description	Number of Entries
Object Type	Variable
Data Type	Unsigned8
Access	Read only
PDO Mapping	No
Default Value	0x05
Lower Limit	0x00
Upper Limit	0xFF

Sub-index	1
Description	Status of all digital inputs and outputs: Bit 0 = Status of digital input 1 Bit 1 = Status of digital input 2 Bit 2 = Status of digital input 3 Bit 3 = Status of digital input 4 Bit 4 = Status of digital output 1 Bit 5 = Status of digital output 2
Object Type	Variable
Data Type	Unsigned32
Access	Read only
PDO Mapping	No
Default Value	0x00
Lower Limit	0x00
Upper Limit	0xFF
Sub-index	2
Description	Status of Digital Input 1
Object Type	Variable
Data Type	Unsigned32
Access	Read only
PDO Mapping	No
Default Value	0x0
Lower Limit	0x0
Upper Limit	0x1
Sub-index	3
Description	Status of Digital Input 2
Object Type	Variable
Data Type	Unsigned32
Access	Read only
PDO Mapping	No
Default Value	0x0
Lower Limit	0x0
Upper Limit	0x1

Sub-index	4
Description	Status of Digital Input 3
Object Type	Variable
Data Type	Unsigned32
Access	Read only
PDO Mapping	No
Default Value	0x0
Lower Limit	0x0
Upper Limit	0x1
Sub-index	5
Description	Status of Digital Input 4
Object Type	Variable
Data Type	Unsigned32
Access	Read only
PDO Mapping	No
Default Value	0x0
Lower Limit	0x0
Upper Limit	0x1
Sub-index	6
Description	Status of Digital Output 1
Object Type	Variable
Data Type	
Access	Read/Write
PDO Mapping	No
Default Value	
Lower Limit	
Upper Limit	
Sub-index	7
Description	Status of Digital Output 2
Object Type	Variable
Data Type	
Access	Read/Write
PDO Mapping	No
Default Value	
Lower Limit	
Upper Limit	

Object 211Eh – Current Feedback

Description	Current Feedback
Object Type	Array
Sub-indices	7
Sub-index	0
Description	Number of Entries
Object Type	Variable
Data Type	Unsigned8
Access	Read only
PDO Mapping	No
Default Value	0x0D
Lower Limit	0x00
Upper Limit	0xFF
Sub-index	1
Description	IQ Actual Current [A] This is the torque building current of the field oriented control.
Object Type	Variable
Data Type	Real32
Access	Read only
PDO Mapping	No
Default Value	0.0
Lower Limit	–
Upper Limit	–
Sub-index	2
Description	ID Actual Current [A]
Object Type	Variable
Data Type	Real32
Access	Read only
PDO Mapping	No
Default Value	0.0
Lower Limit	–
Upper Limit	–

Sub-index	3
Description	Output of the Current Loop, PWM Usage [%]
Object Type	Variable
Data Type	Real32
Access	Read only
PDO Mapping	No
Default Value	0.0
Lower Limit	–
Upper Limit	–
Sub-index	11
Description	Actual Current in Winding A [A]
Object Type	Variable
Data Type	Real32
Access	Read only
PDO Mapping	No
Default Value	0.0
Lower Limit	–
Upper Limit	–
Sub-index	12
Description	Actual Current in Winding B [A]
Object Type	Variable
Data Type	Real32
Access	Read only
PDO Mapping	No
Default Value	0.0
Lower Limit	–
Upper Limit	–
Sub-index	13
Description	Actual Current in Winding C [A]
Object Type	Variable
Data Type	Real32
Access	Read only
PDO Mapping	No
Default Value	0.0
Lower Limit	–
Upper Limit	–

Object 2120h – Temperature

Description	Temperature
Object Type	Array
Sub-indices	3
Sub-index	0
Description	Number of Entries
Object Type	Variable
Data Type	Unsigned8
Access	Read only
PDO Mapping	No
Default Value	0x04
Lower Limit	0x00
Upper Limit	0xFF
Sub-index	2
Description	Drive Temperature [C]
Object Type	Variable
Data Type	Real32
Access	Read only
PDO Mapping	No
Default Value	0.0
Lower Limit	–
Upper Limit	–
Sub-index	4
Description	Motor Temperature [C]
Object Type	Variable
Data Type	Real32
Access	Read only
PDO Mapping	No
Default Value	0.0
Lower Limit	–
Upper Limit	–

Object 2121h – Drive Status

Description	Drive Status
Object Type	Record
Sub-indices	22

Sub-index	0
Description	Number of Entries
Object Type	Variable
Data Type	Unsigned8
Access	Read only
PDO Mapping	No
Default Value	0x02
Lower Limit	0x00
Upper Limit	0xFF
Sub-index	1
Description	TBD
Object Type	Variable
Data Type	Unsigned32
Access	Read only
PDO Mapping	No
Default Value	0x00000000
Lower Limit	0x00000000
Upper Limit	0xFFFFFFFF
ObjFlags	0x00000002
Sub-index	2
Description	Drive Failures STO status is reflected in this sub-index. Refer to the table below.
Object Type	Variable
Data Type	Unsigned32
Access	Read only
PDO Mapping	No
Default Value	0x00000000
Lower Limit	0x00000000
Upper Limit	0xFFFFFFFF

Bit	Error Name	Error Code*	Error Type	Description
0	Hall Error	0x7380	Motor	Inputs (0,0,0) or (1,1,1) or Halls incorrect order
1	Parameters Checksum	0x6310	Init	Parameters corruption
2	Encoder/Hall Sync	0x7381	Motor	Encoder/Halls problem
3	Over Temperature	0x4310	Motor	Temperature above 105°C
4	Over Voltage	0x3210	Motor	Supply voltage above 42V

5	Under Voltage	0x3220	Motor	Supply voltage below 12V
6	Com Sync Loss	0x8180	Comm	Master not communicating
7	Position Tracking	0x8611	Motor	Position loop error greater than Max Tracking Error
8	Drive Power Init	0x5480	Init	Internal initialization test
9	Drive Power C/T	0x5481	Drive	Current/temperature hardware protection
10	Drive Power Fault	0x5410	Drive	Internal continuous test
11	Motor Stall	0x7121	Motor	See Motor Stall parameters
12	Gate Disabled	0x5482	Motor	Gate drive disable motion
13	Drive OSC	0x5280	Init	DSP oscillator clock fail
14	Drive ADC offset	0x7280	Init	Internal sensors initialization test
15	Drive Short Test	0x5483	Motor	Internal drive error
16	STO	0xFF01	Motor	STO disable motion
17	Drv SSI not ready	0x7382	Drive	Internal drive error
18	Drv83xx Setup	0x5484	Drive	Internal drive error
19	Speed Error	0x8400	Motor	Speed not reached
20	Param Table Rev	0x6320	Init	New software
21	Over-current	0x2214	Drive	Over-current in the sequence
22	CANopen	0x6180	Comm	CANopen device hardware

* **Note:** See [Object 603Fh – Error Code](#).

Sub-index	3
Description	Drive Warnings
Object Type	Variable
Data Type	Unsigned32
Access	Read only
PDO Mapping	No
Sub-index	6
Description	External Analog Input Voltage [A2D converter raw counts (0...4096)]
Object Type	Variable
Data Type	Unsigned32
Access	Read only
PDO Mapping	No
Sub-index	20
Description	Current Command Limit 0 = Current command is not limited to continuous current due to the I2t protection. 1 = Current command is limited to continuous current due to the I2t protection.
Object Type	Variable
Data Type	Unsigned32
Access	Read only
PDO Mapping	No
Sub-index	21
Description	I2t Value [A]
Object Type	Variable
Data Type	Real32
Access	Read only
PDO Mapping	No
Sub-index	22
Description	I2t Value [%]
Object Type	Variable
Data Type	Unsigned32
Access	Read only
PDO Mapping	No

Object 2132h – Motion Parameters

Description	Motion Parameters
Object Type	Array
Sub-indices	9
Sub-index	0
Description	Number of Entries
Object Type	Variable
Data Type	Unsigned8
Access	Read only
PDO Mapping	No
Default Value	0x08
Lower Limit	0x00
Upper Limit	0xFF
Sub-index	1
Description	Start-up Enable 0 = Idle 1 = Perform offset calibration upon startup 2 = Enable drive and run ADC test upon startup
Object Type	Variable
Data Type	Unsigned 32
Access	Read/Write
PDO Mapping	No
Default Value	0x0
Lower Limit	0x0
Upper Limit	0x1

Sub-index	2
Description	Operation Mode 0 = Idle 1 = Current Control mode 2 = Speed Control mode 3 = Position Control mode 4 = Speed Position Control mode (speed control with closed position loop)
Object Type	Variable
Data Type	Unsigned 32
Access	Read/Write
PDO Mapping	No
Default Value	0x0000
Lower Limit	0x0000
Upper Limit	0x0006
Sub-index	3
Description	Electrical Commutation Type 0 = Brushed 1 = Brushless with Hall sensor 2 = Brushless with Hall sensor and incremental encoder 3 = Brushless with absolute encoder 4 = Forced commutation
Object Type	Variable
Data Type	Unsigned 32
Access	Read/Write
PDO Mapping	No
Default Value	0x0000
Lower Limit	0x0000
Upper Limit	0x0007

Sub-index	4
Description	Motor Encoder Type 0 = None 1 = Incremental encoder 1 2 = SinCos 3 = SinCos absolute 4 = Incremental encoder 2 5 = SSI 6 = Resolver
Object Type	Variable
Data Type	Unsigned 32
Access	Read/Write
PDO Mapping	No
Default Value	0x0000
Lower Limit	0x0000
Upper Limit	0x0008
Sub-index	5
Description	External Encoder 0 = None 1 = Incremental encoder 1 2 = SinCos 3 = SinCos absolute 4 = Incremental encoder 2 5 = SSI 6 = Resolver
Object Type	Variable
Data Type	Unsigned 32
Access	Read/Write
PDO Mapping	No
Default Value	0x0000
Lower Limit	0x0000
Upper Limit	0x0008

Sub-index	6
Description	Command Source 0 = Digital command source (such as fieldbus or GUI) 1 = Analog command source
Object Type	Variable
Data Type	Unsigned 32
Access	Read/Write
PDO Mapping	No
Default Value	0x0001
Lower Limit	0x0001
Upper Limit	0x0007
Sub-index	7
Description	Speed Loop Feedback 0 = None 1 = Hall 2 = Motor feedback 3 = External feedback
Object Type	Variable
Data Type	Unsigned 32
Access	Read/Write
PDO Mapping	No
Default Value	0x0000
Lower Limit	0x0000
Upper Limit	0x0004
Sub-index	8
Description	Position Loop Feedback 0 = None 1 = Hall 2 = Motor feedback 3 = External feedback
Object Type	Variable
Data Type	Unsigned 32
Access	Read/Write
PDO Mapping	No
Default Value	0x0000
Lower Limit	0x0000
Upper Limit	0x0004

Object 2133h – Motor Parameters

Description	Motor Parameters
Object Type	Array
Sub-indices	3
Sub-index	0
Description	Number of Entries
Object Type	Variable
Data Type	Unsigned8
Access	Read only
PDO Mapping	No
Default Value	0x03
Lower Limit	0x00
Upper Limit	0xFF
Sub-index	2
Description	Pole Pair
Object Type	Variable
Data Type	Unsigned 32
Access	Read/Write
PDO Mapping	No
Default Value	0x0000
Lower Limit	0x0000
Upper Limit	0xFFFF
Sub-index	3
Description	Motion Direction 0 = Positive direction 1 = Negative direction
Object Type	Variable
Data Type	Unsigned 32
Access	Read/Write
PDO Mapping	No
Default Value	0x0
Lower Limit	0x0
Upper Limit	0x1

Sub-index	4
Description	Resistance [Ohm]
Object Type	Variable
Data Type	Real32
Access	Read/Write
PDO Mapping	No
Sub-index	5
Description	Inductance [Henry]
Object Type	Variable
Data Type	Real32
Access	Read/Write
PDO Mapping	No
Sub-index	6
Description	Voltage constant Kv
Object Type	Variable
Data Type	Real32
Access	Read/Write
PDO Mapping	No
Sub-index	7
Description	Friction
Object Type	Variable
Data Type	Real32
Access	Read/Write
PDO Mapping	No
Sub-index	8
Description	Inertia
Object Type	Variable
Data Type	Real32
Access	Read/Write
PDO Mapping	No

Object 2134h – Current Protection

Description	Current protection.
Object Type	Array
Sub-indices	5
Sub-index	0
Description	Number of Entries
Object Type	Variable
Data Type	Unsigned8
Access	Read only
PDO Mapping	No
Default Value	0x05
Lower Limit	0x00
Upper Limit	0xFF
Sub-index	2
Description	Continuous Current Limit [A]
Object Type	Variable
Data Type	Real32
Access	Read/Write
PDO Mapping	No
Default Value	0.0
Lower Limit	–
Upper Limit	–
Sub-index	3
Description	Peak Current Limit [A]
Object Type	Variable
Data Type	Real32
Access	Read/Write
PDO Mapping	No
Default Value	0.0
Lower Limit	–
Upper Limit	–

Sub-index	4
Description	Peak Time [s]
Object Type	Variable
Data Type	Real32
Access	Read/Write
PDO Mapping	No
Default Value	0.0
Lower Limit	–
Upper Limit	–
Sub-index	5
Description	PWM limit [%]
Object Type	Variable
Data Type	Real32
Access	Read/Write
PDO Mapping	No
Default Value	0.0
Lower Limit	–
Upper Limit	–

Object 2135h – Motor Limits

Description	Limiting parameters for motion commands.
Object Type	Array
Sub-indices	10
Sub-index	0
Description	Number of Entries
Object Type	Variable
Data Type	Unsigned8
Access	Read only
PDO Mapping	No
Default Value	0x09
Lower Limit	0x00
Upper Limit	0xFF

Sub-index	1
Description	TBD
Object Type	Variable
Data Type	Integer32
Access	Read only
PDO Mapping	No
Default Value	0x0
Lower Limit	0x80000000
Upper Limit	0x7FFFFFFF
ObjFlags	0x00000002
Sub-index	2
Description	Maximum speed [encoder counts per second]. Value must be positive.
Object Type	Variable
Data Type	Integer32
Access	Read/Write
PDO Mapping	No
Default Value	0x0
Lower Limit	0x80000000
Upper Limit	0x7FFFFFFF
Sub-index	3
Description	Minimum speed [encoder counts per second]. Value must be negative.
Object Type	Variable
Data Type	Integer32
Access	Read/Write
PDO Mapping	No
Default Value	0x0
Lower Limit	0x80000000
Upper Limit	0x7FFFFFFF

Sub-index	4
Description	Maximum position [encoder counts]
Object Type	Variable
Data Type	Integer32
Access	Read/Write
PDO Mapping	No
Default Value	0x0
Lower Limit	0x80000000
Upper Limit	0x7FFFFFFF
Sub-index	5
Description	Minimum position [encoder counts]
Object Type	Variable
Data Type	Integer32
Access	Read/Write
PDO Mapping	No
Default Value	0x0
Lower Limit	0x80000000
Upper Limit	0x7FFFFFFF
Sub-index	6
Description	Enable Position Limit (enable sub-indices 4 and 5) 0 = Position limits are not active 1 = Position limits are active
Object Type	Variable
Data Type	Integer32
Access	Read/Write
PDO Mapping	No
Default Value	0x0
Lower Limit	0x0
Upper Limit	0x1
Sub-index	7
Description	Motor Stuck Current [A]
Object Type	Variable
Data Type	Real32
Access	Read/Write
PDO Mapping	No
Default Value	0.0
Lower Limit	–
Upper Limit	–

Sub-index	8
Description	Motor Stuck Speed [rpm]
Object Type	Variable
Data Type	Integer32
Access	Read/Write
PDO Mapping	No
Default Value	0x0
Lower Limit	0x80000000
Upper Limit	0x7FFFFFFF
Sub-index	9
Description	Motor Stuck Duration [s]
Object Type	Variable
Data Type	Real32
Access	Read/Write
PDO Mapping	No
Default Value	0.0
Lower Limit	–
Upper Limit	–

Object 2136h – Position Profile

Description	Settings for motion in Position Control operation mode, using the position profiler (trajectory generator). See object 2132h sub-index 2.
Object Type	Array
Sub-indices	5
Sub-index	0
Description	Number of Entries
Object Type	Variable
Data Type	Unsigned8
Access	Read only
PDO Mapping	No
Default Value	0x07
Lower Limit	0x0
Upper Limit	0xFF

Sub-index	2
Description	Profiler Mode 0 = None 1 = PID 2 = Trapezoidal motion
Object Type	Variable
Data Type	Integer32
Access	Read/Write
PDO Mapping	No
Default Value	0x00000000
Lower Limit	0x00000000
Upper Limit	0x00000007
Sub-index	3
Description	Profiler Target Velocity [encoder counts per second]
Object Type	Variable
Data Type	Integer32
Access	Read/Write
PDO Mapping	No
Default Value	0x0
Lower Limit	0x80000000
Upper Limit	0x7FFFFFFF
Sub-index	4
Description	Profiler acceleration/deceleration [encoder counts per second²]
Object Type	Variable
Data Type	Integer32
Access	Read/Write
PDO Mapping	No
Default Value	0x0
Lower Limit	0x80000000
Upper Limit	0x7FFFFFFF

Sub-index	7
Description	Max Tracking Error [encoder counts]
Object Type	Variable
Data Type	Integer32
Access	Read/Write
PDO Mapping	No
Default Value	0x0
Lower Limit	0x80000000
Upper Limit	0x7FFFFFFF

Object 2138h – Stop Motion Parameters

Description	Parameters used for a stop (ramp down) sequence, such as during a disable process.
Object Type	Record
Sub-indices	9
Sub-index	0
Description	Number of Entries
Object Type	Variable
Data Type	Unsigned8
Access	Read only
PDO Mapping	No
Default Value	0x08
Lower Limit	0x00
Upper Limit	0xFF
Sub-index	1
Description	Break Control 0 = Motor without brake 1 = Motor with brake
Object Type	Variable
Data Type	Unsigned32
Access	Read/Write
PDO Mapping	No
Default Value	0x00
Lower Limit	0x00
Upper Limit	0x01

Sub-index	2
Description	Speed Threshold [encoder counts per second]
Object Type	Variable
Data Type	Integer32
Access	Read/Write
PDO Mapping	No
Default Value	0x0
Lower Limit	0x80000000
Upper Limit	0x7FFFFFFF
Sub-index	3
Description	Time Threshold [s]
Object Type	Variable
Data Type	Real32
Access	Read/Write
PDO Mapping	No
Default Value	0.0
Lower Limit	–
Upper Limit	–
Sub-index	4
Description	Brake Engage Time [s]
Object Type	Variable
Data Type	Real32
Access	Read/Write
PDO Mapping	No
Default Value	0.0
Lower Limit	–
Upper Limit	–
Sub-index	5
Description	Brake Disengage Time [s]
Object Type	Variable
Data Type	Real32
Access	Read/Write
PDO Mapping	No
Default Value	0.0
Lower Limit	–
Upper Limit	–

Sub-index	6
Description	Stop Timeout [s]
Object Type	Variable
Data Type	Real32
Access	Read/Write
PDO Mapping	No
Default Value	0.0
Lower Limit	–
Upper Limit	–
Sub-index	7
Description	Gate Drive Status in Stop/Disable Condition 0 = Feature not active 1 = Enable gate drive when motor comes to a stop and disables
Object Type	Variable
Data Type	Unsigned32
Access	Read/Write
PDO Mapping	No
Default Value	0x0
Lower Limit	0x0
Upper Limit	0x1
Sub-index	8
Description	Gate Under Motor Disable 0 = Feature not active 1 = Disable gate drive during deceleration (coasting)
Object Type	Variable
Data Type	Boolean
Access	Read/Write
PDO Mapping	No
Default Value	0x0
Lower Limit	0x0
Upper Limit	0x1

Object 2139h – Speed Profile

Description	Settings used by the speed profiler in Speed Control operation mode. See object 2132h sub-index 2.
Object Type	Record
Sub-indices	11
Sub-index	0
Description	Number of Entries
Object Type	Variable
Data Type	Unsigned8
Access	Read only
PDO Mapping	No
Default Value	0x0A
Lower Limit	0x00
Upper Limit	0xFF
Sub-index	1
Description	Profiler Mode 0 = None 1 = PID 2 = Trapezoidal motion
Object Type	Variable
Data Type	Integer32
Access	Read/Write
PDO Mapping	No
Default Value	0x0000
Lower Limit	0x0000
Upper Limit	0x0007
Sub-index	2
Description	Max Speed [counts per second]
Object Type	Variable
Data Type	Integer32
Access	Read/Write
PDO Mapping	No
Default Value	0x0
Lower Limit	0x8000000
Upper Limit	0x7FFFFFFF

Sub-index	3
Description	Min Speed [C/S]
Object Type	Variable
Data Type	Integer32
Access	Read/Write
PDO Mapping	No
Default Value	0x0
Lower Limit	0x8000000
Upper Limit	0x7FFFFFFF
Sub-index	4
Description	Max Acceleration [counts per second ²]
Object Type	Variable
Data Type	Integer32
Access	Read/Write
PDO Mapping	No
Default Value	0x0
Lower Limit	0x8000000
Upper Limit	0x7FFFFFFF
Sub-index	5
Description	Max Deceleration [counts per second ²]
Object Type	Variable
Data Type	Integer32
Access	Read/Write
PDO Mapping	No
Default Value	No
Lower Limit	0x0
Upper Limit	0x8000000
Sub-index	6
Description	Stop Deceleration [counts per second ²]
Object Type	Variable
Data Type	Integer32
Access	Read/Write
PDO Mapping	No
Default Value	0x0
Lower Limit	0x8000000
Upper Limit	0x7FFFFFFF

Sub-index	7
Description	Jerk Max
Object Type	Variable
Data Type	Integer32
Access	Read/Write
PDO Mapping	No
Default Value	0x0
Lower Limit	0x8000000
Upper Limit	0x7FFFFFFF
Sub-index	8
Description	Jerk Div
Object Type	Variable
Data Type	Integer32
Access	Read/Write
PDO Mapping	No
Default Value	0x0
Lower Limit	0x8000000
Upper Limit	0x7FFFFFFF
Sub-index	9
Description	Max Speed Error [counts per second]
Object Type	Variable
Data Type	Integer32
Access	Read/Write
PDO Mapping	No
Default Value	0x0
Lower Limit	0x8000000
Upper Limit	0x7FFFFFFF
Sub-index	10
Description	Speed Error Time [s]
Object Type	Variable
Data Type	Real32
Access	Read/Write
PDO Mapping	No
Default Value	0x0
Lower Limit	–
Upper Limit	–

Object 213Dh – Device Communication

Description	Device communication configuration.
Object Type	Array
Sub-indices	6
Sub-index	0
Description	Number of Entries
Object Type	Variable
Data Type	Unsigned8
Access	Read only
PDO Mapping	No
Default Value	0x05
Lower Limit	0x00
Upper Limit	0xFF
Sub-index	1
Description	TBD
Object Type	Variable
Data Type	Integer32
Access	Read only
PDO Mapping	No
Default Value	0x00000002
Sub-index	2
Description	Uart Baud Rate
Object Type	Variable
Data Type	Unsigned32
Access	Read/Write
PDO Mapping	No
Default Value	0x0006
Lower Limit	0x0000
Upper Limit	0x0008
ObjFlags	0x00000001
Sub-index	3
Description	TBD
Object Type	Variable
Data Type	Integer32
Access	Read only
PDO Mapping	No
Default Value	0x00000002

Sub-index	4
Description	CAN Baud Rate [kbps] 0 = 1000 (= 1 [Mbps]) 1 = 500 2 = 250 3 = 125 4 = 100 5 = 50
Object Type	Variable
Data Type	Unsigned32
Access	Read only
PDO Mapping	No
Default Value	0x0000
Lower Limit	0x0000
Upper Limit	0x0008
ObjFlags	0x00000001
Sub-index	5
Description	Missing Sync Telegram Window [s] After missing any sync telegram from the master for this period of time, the drive generates a Communication Sync Telegram Loss fault. A value of 0 disables this function.
Object Type	Variable
Data Type	Real32
Access	Read/Write
PDO Mapping	No
Default Value	0.0
Lower Limit	–
Upper Limit	–

Object 213Eh – Device Parameters

Description	Information about the drive.
Object Type	Array
Sub-indices	6

Sub-index	0
Description	Number of Entries
Object Type	Variable
Data Type	Unsigned8
Access	Read only
PDO Mapping	No
Default Value	0x0B
Lower Limit	0x00
Upper Limit	0x00
Sub-index	2
Description	Serial Number
Object Type	Variable
Data Type	Unsigned32
Access	Read/Write
PDO Mapping	No
Default Value	0x0
Lower Limit	0x00000000
Upper Limit	0xFFFFFFFF
ObjFlags	0x00000001
Sub-index	3
Description	Hardware Revision
Object Type	Variable
Data Type	Unsigned32
Access	Read/Write
PDO Mapping	No
Default Value	0x0
Lower Limit	0x00000000
Upper Limit	0xFFFFFFFF
ObjFlags	0x00000001

Sub-index	4
Description	Firmware Version
Object Type	Variable
Data Type	Unsigned32
Access	Read only
PDO Mapping	No
Default Value	0x0
Lower Limit	0x00000000
Upper Limit	0xFFFFFFFF
Sub-index	5
Description	Bootloader Firmware Version
Object Type	Variable
Data Type	Integer32
Access	Read only
PDO Mapping	No
Sub-index	9
Description	CAN ID
Object Type	Variable
Data Type	Unsigned32
Access	Read/Write
PDO Mapping	No
Default Value	0x7F
Lower Limit	0x00000000
Upper Limit	0xFFFFFFFF
ObjFlags	0x00000001
Sub-index	11
Description	Firmware Sector Flash Checksum Value
Object Type	Variable
Data Type	Unsigned32
Access	Read only
PDO Mapping	No
Default Value	0x0
Lower Limit	0x00000000
Upper Limit	0xFFFFFFFF

Object 213Fh – Save/Load Parameters

Description	Save/Load Parameters
Object Type	Array
Sub-indices	4
Sub-index	0
Description	Number of Entries
Object Type	Variable
Data Type	Unsigned8
Access	Read only
PDO Mapping	No
Default Value	0x0A
Lower Limit	0x00
Upper Limit	0xFF
Sub-index	1
Description	Save Parameters To Drive Parameters are saved when this sub-index is set to 1.
Object Type	Variable
Data Type	Unsigned32
Access	Write only
PDO Mapping	No
Default Value	0x0
Lower Limit	0x0
Upper Limit	0x01
ObjFlags	0x00000001
Sub-index	2
Description	Load Manufacturer Defaults Parameters are loaded when this sub-index is set to 1.
Object Type	Variable
Data Type	Unsigned32
Access	Read/Write
PDO Mapping	No
Default Value	0x0
Lower Limit	0x0
Upper Limit	0x01
ObjFlags	0x00000001

Sub-index	A
Description	Software Reset of the Drive CPU upon Writing 1 Software resets the drive CPU when this sub-index is set to 1.
Object Type	Variable
Data Type	Unsigned32
Access	Read/Write
PDO Mapping	No
Default Value	0x0
Lower Limit	0x0
Upper Limit	0x01
ObjFlags	0x00000001

Object 2146h – Hall Parameters

Description	Hall Sensor Feedback Parameters
Object Type	Record
Sub-indices	17
Sub-index	0
Description	Number of Entries
Object Type	Variable
Data Type	Unsigned8
Access	Read only
PDO Mapping	No
Default Value	0x10
Lower Limit	0x00
Upper Limit	0xFF
Sub-index	1
Description	TBD
Object Type	Variable
Data Type	Integer32
Access	Read Only
PDO Mapping	No
Default Value	0x80000000
Lower Limit	0x7FFFFFFF
Upper Limit	0x00000002

Sub-index	2
Description	Motor Hall Enable 0 = Disable 1 = Enable
Object Type	Variable
Data Type	Unsigned32
Access	Read/Write
PDO Mapping	No
Default Value	0x0
Lower Limit	0x00000000
Upper Limit	0xFFFFFFFF
Sub-index	3
Description	Roll High Upper modulo threshold of the Hall position.
Object Type	Variable
Data Type	Integer32
Access	Read/Write
PDO Mapping	No
Default Value	0x2000
Lower Limit	0x00000000
Upper Limit	0xFFFFFFFF
Sub-index	4
Description	Roll Low Lower modulo threshold of the Hall position.
Object Type	Variable
Data Type	Integer32
Access	Read/Write
PDO Mapping	No
Default Value	0x0
Lower Limit	0x00000000
Upper Limit	0xFFFFFFFF

Sub-index	5
Description	Direction 0 = Positive direction 1 = Negative direction
Object Type	Variable
Data Type	Unsigned32
Access	Read/Write
PDO Mapping	No
Default Value	0x0
Lower Limit	0x0
Upper Limit	0x1
Sub-index	6
Description	Counts Per Revolution
Object Type	Variable
Data Type	Integer32
Access	Read/Write
PDO Mapping	No
Default Value	0x0
Lower Limit	0x00000000
Upper Limit	0xFFFFFFFF
Sub-index	7
Description	Speed LPF Cut-off Low pass filter cut-off frequency for generating the actual velocity out of the Hall signals [Hz].
Object Type	Variable
Data Type	Real32
Access	Read/Write
PDO Mapping	No
Default Value	10.0
Lower Limit	–
Upper Limit	–

Sub-index	8
Description	Hall Angle 1
Object Type	Variable
Data Type	Real32
Access	Read/Write
PDO Mapping	No
Default Value	0.0
Lower Limit	–
Upper Limit	–
ObjFlags	0x00000001
Sub-index	9
Description	Hall Angle 2
Object Type	Variable
Data Type	Real32
Access	Read/Write
PDO Mapping	No
Default Value	0.0
Lower Limit	–
Upper Limit	–
ObjFlags	0x00000001
Sub-index	10
Description	Hall Angle 3
Object Type	Variable
Data Type	Real32
Access	Read/Write
PDO Mapping	No
Default Value	0.0
Lower Limit	–
Upper Limit	–
ObjFlags	0x00000001

Sub-index	11
Description	Hall Angle 4
Object Type	Variable
Data Type	Real32
Access	Read/Write
PDO Mapping	No
Default Value	0.0
Lower Limit	–
Upper Limit	–
ObjFlags	0x00000001
Sub-index	12
Description	Hall Angle 5
Object Type	Variable
Data Type	Real32
Access	Read/Write
PDO Mapping	No
Default Value	0.0
Lower Limit	–
Upper Limit	–
ObjFlags	0x00000001
Sub-index	13
Description	Hall Angle 6
Object Type	Variable
Data Type	Real32
Access	Read/Write
PDO Mapping	No
Default Value	0.0
Lower Limit	–
Upper Limit	–
ObjFlags	0x00000001

Sub-index	14
Description	TBD
Object Type	Variable
Data Type	Integer32
Access	Read only
PDO Mapping	No
Default Value	0x0
Lower Limit	0x80000000
Upper Limit	0x7FFFFFFF
ObjFlags	0x00000002
Sub-index	15
Description	TBD
Object Type	Variable
Data Type	Integer32
Access	Read only
PDO Mapping	No
Default Value	0x0
Lower Limit	0x80000000
Upper Limit	0x7FFFFFFF
ObjFlags	0x00000002
Sub-index	16
Description	Sample Period
Object Type	Variable
Data Type	Integer32
Access	Read/Write
PDO Mapping	No
Default Value	0x0
Lower Limit	0x80000000
Upper Limit	0x7FFFFFFF

Object 2147h – Encoder 1 Parameters

Description	Incremental Encoder 1 Parameters
Object Type	Record
Sub-indices	16

Sub-index	0
Description	Number of Entries
Object Type	Variable
Data Type	Unsigned8
Access	Read only
PDO Mapping	No
Default Value	0x0F
Lower Limit	0x00
Upper Limit	0x0F
Sub-index	1
Description	TBD
Object Type	Variable
Data Type	Integer32
Access	Read only
PDO Mapping	No
Default Value	–
Lower Limit	–
Upper Limit	–
ObjFlags	0x00000002
Sub-index	2
Description	Incremental Encoder 1 Enable 0 = Disable 1 = Enable
Object Type	Variable
Data Type	Unsigned32
Access	Read/Write
PDO Mapping	No
Default Value	–
Lower Limit	–
Upper Limit	–

Sub-index	3
Description	Roll High Upper modulo threshold of the encoder 1 position.
Object Type	Variable
Data Type	Integer32
Access	Read/Write
PDO Mapping	No
Default Value	0x000C8000
Lower Limit	0x80000000
Upper Limit	0x7FFFFFFF
Sub-index	4
Description	Roll Low Lower modulo threshold of the encoder 1 position.
Object Type	Variable
Data Type	Integer32
Access	Read/Write
PDO Mapping	No
Default Value	0x0
Lower Limit	0x80000000
Upper Limit	0x7FFFFFFF
Sub-index	5
Description	Direction 0 = Positive direction 1 = Negative direction
Object Type	Variable
Data Type	Integer32
Access	Read/Write
PDO Mapping	No
Default Value	0x0
Lower Limit	0x0
Upper Limit	0x1

Sub-index	6
Description	Counts Per Revolution
Object Type	Variable
Data Type	Integer32
Access	Read/Write
PDO Mapping	No
Default Value	0x00002000
Lower Limit	0x80000000
Upper Limit	0x7FFFFFFF
Sub-index	7
Description	Speed LPF Low pass filter cut-off frequency for generating the actual velocity out of the incremental encoder 1 signals [Hz].
Object Type	Variable
Data Type	Real32
Access	Read/Write
PDO Mapping	No
Default Value	100.0
Lower Limit	–
Upper Limit	–
Sub-index	8
Description	Index Mode
Object Type	Variable
Data Type	Integer32
Access	Read/Write
PDO Mapping	No
Default Value	0x00
Lower Limit	0x00
Upper Limit	0x02
Sub-index	9
Description	Index Reset
Object Type	Variable
Data Type	Integer32
Access	Read/Write
PDO Mapping	No
Default Value	0x1
Lower Limit	0x80000000
Upper Limit	0x7FFFFFFF

Sub-index	10
Description	TBD
Object Type	Variable
Data Type	Integer32
Access	Read only
PDO Mapping	No
Default Value	–
Lower Limit	–
Upper Limit	–
ObjFlags	0x00000002
Sub-index	11
Description	TBD
Object Type	Variable
Data Type	Integer32
Access	Read only
PDO Mapping	No
Default Value	–
Lower Limit	–
Upper Limit	–
ObjFlags	0x00000002
Sub-index	12
Description	TBD
Object Type	Variable
Data Type	Integer32
Access	Read only
PDO Mapping	No
Default Value	–
Lower Limit	–
Upper Limit	–
ObjFlags	0x00000002

Sub-index	13
Description	TBD
Object Type	Variable
Data Type	Integer32
Access	Read/Write
PDO Mapping	No
Default Value	
Lower Limit	
Upper Limit	
ObjFlags	0x00000002
Sub-index	14
Description	Set Position Value
Object Type	Variable
Data Type	Integer32
Access	Read/Write
PDO Mapping	No
Default Value	0x0
Lower Limit	0x80000000
Upper Limit	0x7FFFFFFF
ObjFlags	0x00000001
Sub-index	15
Description	Resolution SinCos
Object Type	Variable
Data Type	Unsigned32
Access	Read/Write
PDO Mapping	No
Default Value	0x08
Lower Limit	0x00
Upper Limit	0x0A

Object 2149h – SSI Parameters

Description	SSI Feedback Parameters
Object Type	Array
Sub-indices	17

Sub-index	0
Description	Number of Entries
Object Type	Variable
Data Type	Unsigned8
Access	Read only
PDO Mapping	No
Default Value	0x10
Lower Limit	0x00
Upper Limit	0xFF
Sub-index	1
Description	TBD
Object Type	Variable
Data Type	Integer32
Access	Read only
PDO Mapping	No
Default Value	–
Lower Limit	–
Upper Limit	–
ObjFlags	0x00000002
Sub-index	2
Description	SSI Encoder 1 Enable 0 = Disable 1 = Enable
Object Type	Variable
Data Type	Unsigned32
Access	Read/Write
PDO Mapping	No
Default Value	–
Lower Limit	–
Upper Limit	–

Sub-index	3
Description	Roll High Upper modulo threshold of the SSI encoder position.
Object Type	Variable
Data Type	Integer32
Access	Read/Write
PDO Mapping	No
Default Value	–
Lower Limit	–
Upper Limit	–
Sub-index	4
Description	Roll Low Lower modulo threshold of the SSI encoder position.
Object Type	Variable
Data Type	Integer32
Access	Read/Write
PDO Mapping	No
Default Value	–
Lower Limit	–
Upper Limit	–
Sub-index	5
Description	Direction 0 = Positive direction 1 = Negative direction
Object Type	Variable
Data Type	Unsigned32
Access	Read/Write
PDO Mapping	No
Default Value	–
Lower Limit	–
Upper Limit	–

Sub-index	6
Description	Counts Per Revolution
Object Type	Variable
Data Type	Integer32
Access	Read/Write
PDO Mapping	No
Default Value	–
Lower Limit	–
Upper Limit	–
ObjFlags	0x00000002
Sub-index	7
Description	LPF Cut-off Low pass filter cut-off frequency for generating the actual velocity out of the incremental encoder 1 signals [Hz].
Object Type	Variable
Data Type	Real32
Access	Read/Write
PDO Mapping	No
Default Value	–
Lower Limit	–
Upper Limit	–
Sub-index	8
Description	Baud Rate Baud rate can only be selected as max. 90 MHz/4, and in general only in increments of 90 MHz/ n , where $n = 4...128$.
Object Type	Variable
Data Type	Unsigned32
Access	Read/Write
PDO Mapping	No
Default Value	–
Lower Limit	–
Upper Limit	–

Sub-index	9
Description	Encoder Bits per Revolution
Object Type	Variable
Data Type	Unsigned32
Access	Read/Write
PDO Mapping	No
Default Value	–
Lower Limit	–
Upper Limit	–
Sub-index	10
Description	Clock Phase SPI clocking scheme setting. For more information, contact Support.
Object Type	Variable
Data Type	Unsigned32
Access	Read/Write
PDO Mapping	No
Default Value	–
Lower Limit	–
Upper Limit	–
Sub-index	11
Description	Clock Polarity SPI clocking scheme setting. For more information, contact Support.
Object Type	Variable
Data Type	Unsigned32
Access	Read/Write
PDO Mapping	No
Default Value	–
Lower Limit	–
Upper Limit	–

Sub-index	12
Description	Tail Bits
Object Type	Variable
Data Type	Unsigned32
Access	Read/Write
PDO Mapping	No
Default Value	–
Lower Limit	–
Upper Limit	–
Sub-index	13
Description	Packet Delay
Object Type	Variable
Data Type	Unsigned32
Access	Read/Write
PDO Mapping	No
Default Value	–
Lower Limit	–
Upper Limit	–
Sub-index	14
Description	Calibrated Angle
Object Type	Variable
Data Type	Real32
Access	Read/Write
PDO Mapping	No
Default Value	–
Lower Limit	–
Upper Limit	–
Sub-index	15
Description	Head Bits
Object Type	Variable
Data Type	Unsigned32
Access	Read/Write
PDO Mapping	No
Default Value	–
Lower Limit	–
Upper Limit	–

Sub-index	16
Description	Sample Period
Object Type	Variable
Data Type	Unsigned32
Access	Read/Write
PDO Mapping	No
Default Value	–
Lower Limit	–
Upper Limit	–

Object 214Eh – Interpolation Gear

Description	Interpolation Gear
Object Type	Array
Sub-indices	4
Sub-index	0
Description	Number of Entries
Object Type	Variable
Data Type	Unsigned8
Access	Read only
PDO Mapping	No
Default Value	0x04
Lower Limit	0x00
Upper Limit	0xFF
Sub-index	1
Description	TBD
Object Type	Variable
Data Type	Integer32
Access	Read only
PDO Mapping	No
Default Value	–
Lower Limit	–
Upper Limit	–
ObjFlags	0x00000002

Sub-index	2
Description	Enable External Interpolation
Object Type	Variable
Data Type	Unsigned32
Access	Read/Write
PDO Mapping	No
Default Value	0x0
Lower Limit	0x0
Upper Limit	0x1
Sub-index	3
Description	Interpolation Gear
Object Type	Variable
Data Type	Real32
Access	Read/Write
PDO Mapping	No
Default Value	0.0
Lower Limit	–
Upper Limit	–
Sub-index	4
Description	Max Encoder - Hall Sync Error [C]
Object Type	Variable
Data Type	Real32
Access	Read/Write
PDO Mapping	No
Default Value	0.0
Lower Limit	–
Upper Limit	–

Object 2151h – Current PID

Description	Current Loop Parameters
Object Type	Record
Sub-indices	12

Sub-index	0
Description	Number of Entries
Object Type	Variable
Data Type	Unsigned8
Access	Read only
PDO Mapping	No
Default Value	0x0B
Lower Limit	0x00
Upper Limit	0xFF
Sub-index	1
Description	TBD
Object Type	Variable
Data Type	Integer32
Access	Read only
PDO Mapping	No
Default Value	–
Lower Limit	–
Upper Limit	–
ObjFlags	0x00000002
Sub-index	2
Description	K_p – Proportional Gain of the Current Loop
Object Type	Variable
Data Type	Real32
Access	Read/Write
PDO Mapping	No
Default Value	0.0
Lower Limit	–
Upper Limit	–
Sub-index	3
Description	K_i – Integral Gain of the Current Loop
Object Type	Variable
Data Type	Real32
Access	Read/Write
PDO Mapping	No
Default Value	0.0
Lower Limit	–
Upper Limit	–

Sub-index	4
Description	TBD
Object Type	Variable
Data Type	Real32
Access	Read only
PDO Mapping	No
Default Value	–
Lower Limit	–
Upper Limit	–
ObjFlags	0x00000002
Sub-index	5
Description	TBD
Object Type	Variable
Data Type	Real32
Access	Read only
PDO Mapping	No
Default Value	–
Lower Limit	–
Upper Limit	–
ObjFlags	0x00000002
Sub-index	6
Description	TBD
Object Type	Variable
Data Type	Real32
Access	Read only
PDO Mapping	No
Default Value	–
Lower Limit	–
Upper Limit	–
ObjFlags	0x00000002

Sub-index	7
Description	TBD
Object Type	Variable
Data Type	Integer32
Access	Read only
PDO Mapping	No
Default Value	–
Lower Limit	–
Upper Limit	–
ObjFlags	0x00000002
Sub-index	8
Description	TBD
Object Type	Variable
Data Type	Integer32
Access	Read only
PDO Mapping	No
Default Value	–
Lower Limit	–
Upper Limit	–
ObjFlags	0x00000002
Sub-index	9
Description	TBD
Object Type	Variable
Data Type	Integer32
Access	Read only
PDO Mapping	No
Default Value	–
Lower Limit	–
Upper Limit	–
ObjFlags	0x00000002

Sub-index	10
Description	TBD
Object Type	Variable
Data Type	Integer32
Access	Read only
PDO Mapping	No
Default Value	–
Lower Limit	–
Upper Limit	–
ObjFlags	0x00000002
Sub-index	11
Description	Closed Loop This entry has no meaning for the current loop.
Object Type	Variable
Data Type	Integer32
Access	Read/Write
PDO Mapping	No
Default Value	0x0
Lower Limit	0x80000000
Upper Limit	0x7FFFFFFF

Object 2152h – Speed PID

Description	Speed Loop Parameters
Object Type	Record
Sub-indices	12
Sub-index	0
Description	Number of Entries
Object Type	Variable
Data Type	Unsigned8
Access	Read only
PDO Mapping	No
Default Value	0x0B
Lower Limit	0x00
Upper Limit	0xFF

Sub-index	1
Description	TBD
Object Type	Variable
Data Type	Integer32
Access	Read only
PDO Mapping	No
Default Value	–
Lower Limit	–
Upper Limit	–
ObjFlags	0x00000002
Sub-index	2
Description	Kp – Proportional Gain of the Speed Loop
Object Type	Variable
Data Type	Real32
Access	Read/Write
PDO Mapping	No
Default Value	0.0
Lower Limit	–
Upper Limit	–
Sub-index	3
Description	Ki – Integral Gain of The Speed Loop
Object Type	Variable
Data Type	Real32
Access	Read/Write
PDO Mapping	No
Default Value	0.0
Lower Limit	–
Upper Limit	–
Sub-index	4
Description	Kc (Not in use)
Object Type	Variable
Data Type	Real32
Access	Read/Write
PDO Mapping	No
Default Value	
Lower Limit	
Upper Limit	

Sub-index	5
Description	Kd (Not in use)
Object Type	Variable
Data Type	Real32
Access	Read/Write
PDO Mapping	No
Default Value	
Lower Limit	
Upper Limit	
Sub-index	6
Description	Kp Range (Not in use)
Object Type	Variable
Data Type	Real32
Access	Read/Write
PDO Mapping	No
Default Value	
Lower Limit	
Upper Limit	
Sub-index	7
Description	Range
Object Type	Variable
Data Type	Integer32
Access	Read/Write
PDO Mapping	No
Default Value	
Lower Limit	
Upper Limit	
Sub-index	8
Description	TBD
Object Type	Variable
Data Type	Integer32
Access	Read only
PDO Mapping	No
Default Value	–
Lower Limit	–
Upper Limit	–
ObjFlags	0x00000002

Sub-index	9
Description	TBD
Object Type	Variable
Data Type	Integer32
Access	Read only
PDO Mapping	No
Default Value	–
Lower Limit	–
Upper Limit	–
ObjFlags	0x00000002
Sub-index	10
Description	TBD
Object Type	Variable
Data Type	Integer32
Access	Read only
PDO Mapping	No
Default Value	–
Lower Limit	–
Upper Limit	–
ObjFlags	0x00000002
Sub-index	11
Description	Closed Loop 0 = Disable loop 1 = Enable loop
Object Type	Variable
Data Type	Integer32
Access	Read/Write
PDO Mapping	No
Default Value	
Lower Limit	
Upper Limit	

Object 2153h – Position PID

Description	Position Loop Parameters
Object Type	Array
Sub-indices	12

Sub-index	0
Description	Number of Entries
Object Type	Variable
Data Type	Unsigned8
Access	Read only
PDO Mapping	No
Default Value	0x0B
Lower Limit	0x00
Upper Limit	0xFF
Sub-index	1
Description	TBD
Object Type	Variable
Data Type	Integer32
Access	Read only
PDO Mapping	No
Default Value	–
Lower Limit	–
Upper Limit	–
ObjFlags	0x00000002
Sub-index	2
Description	K_p – Proportional Gain of the Position Loop
Object Type	Variable
Data Type	Real32
Access	Read/Write
PDO Mapping	No
Default Value	0.0
Lower Limit	–
Upper Limit	–
Sub-index	3
Description	K_i – Integral Gain of the Position Loop
Object Type	Variable
Data Type	Real32
Access	Read/Write
PDO Mapping	No
Default Value	0.0
Lower Limit	–
Upper Limit	–

Sub-index	4
Description	Kc (Not in use)
Object Type	Variable
Data Type	Real32
Access	Read/Write
PDO Mapping	No
Default Value	
Lower Limit	
Upper Limit	
Sub-index	5
Description	Kd (Not in use)
Object Type	Variable
Data Type	Real32
Access	Read/Write
PDO Mapping	No
Default Value	
Lower Limit	
Upper Limit	
Sub-index	6
Description	Kp Range (Not in use)
Object Type	Variable
Data Type	Real32
Access	Read/Write
PDO Mapping	No
Default Value	
Lower Limit	
Upper Limit	
Sub-index	7
Description	Range
Object Type	Variable
Data Type	Integer32
Access	Read/Write
PDO Mapping	No
Default Value	
Lower Limit	
Upper Limit	

Sub-index	8
Description	TBD
Object Type	Variable
Data Type	Integer32
Access	Read only
PDO Mapping	No
Default Value	
Lower Limit	
Upper Limit	
ObjFlags	0x00000002
Sub-index	9
Description	TBD
Object Type	Variable
Data Type	Integer32
Access	Read only
PDO Mapping	No
Default Value	
Lower Limit	
Upper Limit	
ObjFlags	0x00000002
Sub-index	10
Description	TBD
Object Type	Variable
Data Type	Integer32
Access	Read only
PDO Mapping	No
Default Value	
Lower Limit	
Upper Limit	
ObjFlags	0x00000002

Sub-index	11
Description	Closed Loop 0 = Disable loop 1 = Enable loop
Object Type	Variable
Data Type	Integer32
Access	Read/Write
PDO Mapping	No
Default Value	0x0
Lower Limit	0x80000000
Upper Limit	0x7FFFFFFF

Object 2154h – Hall Map

Description	Hall Map
Object Type	Array
Sub-indices	7
Sub-index	0
Description	Number of Entries
Object Type	Variable
Data Type	Unsigned8
Access	Read only
PDO Mapping	No
Default Value	0x07
Lower Limit	0x00
Upper Limit	0xFF
Sub-index	1
Description	TBD
Object Type	Variable
Data Type	Unsigned32
Access	Read only
PDO Mapping	No
Default Value	
Lower Limit	
Upper Limit	
ObjFlags	0x00000002

Sub-index	2
Description	Hall Map 0
Object Type	Variable
Data Type	Unsigned32
Access	Read/Write
PDO Mapping	No
Default Value	0x0000
Lower Limit	0x0000
Upper Limit	0xFFFF
Sub-index	3
Description	Hall Map 1
Object Type	Variable
Data Type	Unsigned32
Access	Read/Write
PDO Mapping	No
Default Value	0x0001
Lower Limit	0x0000
Upper Limit	0xFFFF
Sub-index	4
Description	Hall Map 2
Object Type	Variable
Data Type	Unsigned32
Access	Read/Write
PDO Mapping	No
Default Value	0x0010
Lower Limit	0x0000
Upper Limit	0xFFFF
Sub-index	5
Description	Hall Map 3
Object Type	Variable
Data Type	Unsigned32
Access	Read/Write
PDO Mapping	No
Default Value	0x0011
Lower Limit	0x0000
Upper Limit	0xFFFF

Sub-index	6
Description	Hall Map 4
Object Type	Variable
Data Type	Unsigned32
Access	Read/Write
PDO Mapping	No
Default Value	0x0100
Lower Limit	0x0000
Upper Limit	0xFFFF
Sub-index	7
Description	Hall Map 5
Object Type	Variable
Data Type	Unsigned32
Access	Read/Write
PDO Mapping	No
Default Value	0x0101
Lower Limit	0x0000
Upper Limit	0xFFFF

Object 2165h – Current IIR Filter

Description	Recursive IIR BiQuad filter coefficients. The filter is located ahead of the IQ command value and can be set depending on the filter coefficients of different kinds of filters.
Object Type	Array
Sub-indices	9
Sub-index	0
Description	Number of Entries
Object Type	Variable
Data Type	Unsigned8
Access	Read only
PDO Mapping	No
Default Value	0x08
Lower Limit	0x00
Upper Limit	0xFF

Sub-index	1
Description	Enable 0 = Disable BiQuad filter 1 = Enable BiQuad filter
Object Type	Variable
Data Type	Unsigned32
Access	Read/Write
PDO Mapping	No
Default Value	0x0
Lower Limit	0x0
Upper Limit	0x1
ObjFlags	0x00000001
Sub-index	2
Description	Number of Sections
Object Type	Variable
Data Type	Unsigned32
Access	Read/Write
PDO Mapping	No
Default Value	0x0000
Lower Limit	0x0000
Upper Limit	0x0003
Sub-index	3
Description	Section 0 a[0]
Object Type	Variable
Data Type	Real32
Access	Read/Write
PDO Mapping	No
Default Value	0.0
Lower Limit	–
Upper Limit	–

Sub-index	4
Description	Section 0 a[1] Coefficient 1 in the backward path of the filter, multiplied by the last output y_{n-1} of the recursive filter.
Object Type	Variable
Data Type	Real32
Access	Read/Write
PDO Mapping	No
Default Value	0.0
Lower Limit	–
Upper Limit	–
Sub-index	5
Description	Section 0 a[2] Coefficient 2 in the backward path of the filter, multiplied by the last output y_{n-2} of the recursive filter.
Object Type	Variable
Data Type	Real32
Access	Read/Write
PDO Mapping	No
Default Value	0.0
Lower Limit	–
Upper Limit	–
Sub-index	6
Description	Section 0 b[0] Coefficient 0 in the forward path of the filter, multiplied by the current input x_n of the recursive filter.
Object Type	Variable
Data Type	Real32
Access	Read/Write
PDO Mapping	No
Default Value	0.0
Lower Limit	–
Upper Limit	–

Sub-index	7
Description	Section 0 b[1] Coefficient 1 in the forward path of the filter, multiplied by the last input x_{n-1} of the recursive filter.
Object Type	Variable
Data Type	Real32
Access	Read/Write
PDO Mapping	No
Default Value	0.0
Lower Limit	–
Upper Limit	–
Sub-index	8
Description	Section 0 b[2] Coefficient 2 in the forward path of the filter, multiplied by the second last input x_{n-2} of the recursive filter.
Object Type	Variable
Data Type	Real32
Access	Read/Write
PDO Mapping	No
Default Value	0.0
Lower Limit	–
Upper Limit	–

Object 216Eh – Analog Command

Description	Settings for modes of operation using an external analog input signal.
Object Type	Record
Sub-indices	8
Sub-index	0
Description	Number of Entries
Object Type	Variable
Data Type	Unsigned8
Access	Read only
PDO Mapping	No
Default Value	0x07
Lower Limit	0x00
Upper Limit	0xFF

Sub-index	1
Description	Ampere/Volt Converts the analog input into a current command value for analog Torque operation mode.
Object Type	Variable
Data Type	Real32
Access	Read/Write
PDO Mapping	No
Default Value	
Lower Limit	
Upper Limit	
Sub-index	2
Description	RPM/Volt Converts the analog input into a velocity command value for analog Velocity operation mode
Object Type	Variable
Data Type	Real32
Access	Read/Write
PDO Mapping	No
Default Value	
Lower Limit	
Upper Limit	
Sub-index	3
Description	Counts/Volt Converts the analog input into a position command value in encoder counts for analog Position operation mode.
Object Type	Variable
Data Type	Real32
Access	Read/Write
PDO Mapping	No
Default Value	
Lower Limit	
Upper Limit	

Sub-index	4
Description	Offset Defines a constant offset added to the measured voltage [V].
Object Type	Variable
Data Type	Real32
Access	Read/Write
PDO Mapping	No
Default Value	
Lower Limit	
Upper Limit	
Sub-index	5
Description	Dead Zone Defines the zone in which the measured voltage is considered zero (dead-band) [V].
Object Type	Variable
Data Type	Real32
Access	Read/Write
PDO Mapping	No
Default Value	
Lower Limit	
Upper Limit	
Sub-index	6
Description	Direction Changes the algebraic sign of the command voltage after the A2D conversion for changing motion direction. 0 = Maintains direction of requested motion 1 = Invert direction of requested motion
Object Type	Variable
Data Type	Integer32
Access	Read/Write
PDO Mapping	No
Default Value	
Lower Limit	
Upper Limit	

Sub-index	7
Description	LPF Cut-off The analog input value is forwarded to a 1 st order low-pass filter. This value is the cut-off frequency of that filter [Hz].
Object Type	Variable
Data Type	Real32
Access	Read/Write
PDO Mapping	No
Default Value	
Lower Limit	
Upper Limit	

7 Device Objects

Object 603Fh – Error Code

Description	<p>This object returns the error code of the last error that occurred in the drive. See Drive Failure Register in Object 2121h – Drive Status.</p> <p>CAN error codes according to CiA301 and CiA402 standard, see:</p> <p>CiA 301 Chapter 7.2.7.1 Emergency object usage</p> <p>CiA 402 Part 2, Chapter 7.1: Error codes</p> <p>Error codes fall into the following scheme: 0xABCD</p> <p>A = Main group of the error code (CiA 301 standard)</p> <p>B = Subgroup of the error code (CiA 301 standard)</p> <p>C, D = Specific error code (CiA 301 and CiA 402 standards)</p> <p>Note: According to CiA 402, error codes between xx80h...xxFFh are manufacturer specific.</p>
Object Type	Variable
Data Type	Unsigned16
Access	Read only
PDO Mapping	Yes
Default Value	0x0
Lower Limit	0x0
Upper Limit	0xFFFF

Object 6040h – Controlword

Description	<p>This object sets the operating states and modes of the state machine.</p> <p>It is used to control the CiA-402 FSA, CiA-402 modes, and manufacturer-specific entities.</p> <p>This object is organized bit-wise. The bits have the following meaning:</p> <ul style="list-style-type: none"> bit 0: Switch on bit 1: Enable voltage bit 2: Quick stop bit 3: Enable operation bits 4-6: Mode specific bit 7: Fault reset bit 8: Halt bit 9: Mode specific bit 10: Reserved bits 11-15: Manufacturer specific
Object Type	Variable
Data Type	Unsigned16
Access	Read/Write
PDO Mapping	Yes
Default Value	0x0000
Lower Limit	0x0000
Upper Limit	0xFFFF

Object 6041h – Statusword

Description	This object indicates the current state of the FSA, the operation mode, and manufacturer specific entities. This object is organized bit-wise. The bits have the following meaning: bit 0: Ready to switch on bit 1: Switched on bit 2: Operation enabled bit 3: Fault bit 4: Voltage enabled bit 5: Quick stop 6: Switch on disabled 7: Warning 8: Manufacturer specific 9: Remote bit 10: Target reached bit 11: Internal limit active bits 12-13: Mode specific bits14-15: Manufacturer specific
Object Type	Variable
Data Type	Unsigned16
Access	Read only
PDO Mapping	Yes
Default Value	–
Lower Limit	0x0000
Upper Limit	0xFFFF

Object 605Ah – Quick Stop Option Code

Description	Quick Stop Option Code
Object Type	Variable
Data Type	Integer16
Access	Read/Write
PDO Mapping	No
Default Value	0x0002
Lower Limit	0x8000
Upper Limit	0x0008

Object 605Dh – Halt Option Code

Description	Halt Option Code
Object Type	Variable
Data Type	Integer16
Access	Read/Write
PDO Mapping	No
Default Value	0x0001
Lower Limit	0x8000
Upper Limit	0x0004

Object 605Eh – Fault Response Option Code

Description	Fault Response Option Code
Object Type	Variable
Data Type	Integer16
Access	Read/Write
PDO Mapping	No
Default Value	0xFFFF
Lower Limit	0x8000
Upper Limit	0x0004

Object 6060h – Modes of Operation

Description	<p>This object indicates the requested operation mode. The current operating mode can only be read in the object Modes of Operation Display (6061h). As a change of the operating mode might require some time to process, wait until the new selected mode appears in the object Modes of Operation Display.</p> <p>Possible values:</p> <ul style="list-style-type: none"> 1 Profile Position mode (position controller with positioning operation) 3 Profile Velocity mode (speed controller with setpoint ramp) 4 Profile Torque mode (torque controller with setpoint ramp) 6 Homing mode (homing operation) 9 Cyclic Synchronous Velocity mode <p>Note: Only Velocity Profile (3) and Cyclic Synchronous Velocity (9) modes have been tested.</p>
Object Type	Variable
Data Type	Integer8
Access	Read/Write
PDO Mapping	Yes
Default Value	0x00
Lower Limit	0x80
Upper Limit	0x0A

Object 6061h – Modes of Operation Display

Description	This object provides the actual operation mode. Possible values: 1 Profile Position mode (position controller with positioning operation) 3 Profile Velocity mode (speed controller with setpoint ramp) 4 Profile Torque mode (torque controller with setpoint ramp) 6 Homing mode (homing operation) 9 Cyclic Synchronous Velocity mode Note: Only Velocity Profile (3) and Cyclic Synchronous Velocity (9) modes have been tested.
Object Type	Variable
Data Type	Integer8
Access	Read only
PDO Mapping	Yes
Default Value	0x00
Lower Limit	0x80
Upper Limit	0x0A

Object 6062h – Position Demand Value

Description	This object indicates the demanded position value.
Object Type	Variable
Data Type	Integer32
Access	Read only
PDO Mapping	Yes
Default Value	0x0
Lower Limit	0x80000000
Upper Limit	0x7FFFFFFF
Unit	CAN user position units

Object 6064h – Position Actual Value

Description	This object provides the actual value of the position measurement device. The value is given in user-defined position units.
Object Type	Variable
Data Type	Integer32
Access	Read only
PDO Mapping	Yes
Default Value	–
Lower Limit	0x80000000
Upper Limit	0x7FFFFFFF
Unit	CAN user position units

Object 606Bh – Velocity Demand Value

Description	This object provides the output value of the trajectory generator.
Object Type	Variable
Data Type	Integer32
Access	Read only
PDO Mapping	Yes
Default Value	0x00000000
Lower Limit	0x80000000
Upper Limit	0x7FFFFFFF
Unit	CAN user velocity units

Object 606Ch – Velocity Actual Value

Description	This object provides the actual velocity value derived either from the velocity sensor or the position sensor.
Object Type	Variable
Data Type	Integer32
Access	Read only
PDO Mapping	Yes
Default Value	0x00000000
Lower Limit	0x80000000
Upper Limit	0x7FFFFFFF
Unit	CAN user velocity units

Object 606Dh – Velocity Window

Description	This object indicates the configured velocity window. <i>Not yet available.</i>
Object Type	Variable
Data Type	Unsigned16
Access	Read/Write
PDO Mapping	Yes
Default Value	0x0000
Lower Limit	0x0000
Upper Limit	0xFFFF
Unit	CAN user velocity units

Object 606Eh – Velocity Window Time

Description	This object indicates the configured velocity window time. <i>Not yet available.</i>
Object Type	Variable
Data Type	Unsigned16
Access	Read/Write
PDO Mapping	Yes
Default Value	0x0000
Lower Limit	0x0000
Upper Limit	0xFFFF
Unit	ms

Object 6073h – Maximum Current

Description	This object indicates the configured maximum permissible torque creating current in the motor. The value is given per thousand of rated current.
Object Type	Variable
Data Type	Unsigned16
Access	Read/Write
PDO Mapping	Yes
Default Value	0x0000
Lower Limit	0x0000
Upper Limit	0xFFFF
Unit	mA

Object 6075h – Motor Rated Current

Description	This object indicates the motor rated current. It is taken from the motor nameplate.
Object Type	Variable
Data Type	Unsigned32
Access	Read/Write
PDO Mapping	No
Default Value	0x00000000
Lower Limit	0x00000000
Upper Limit	0xFFFFFFFF
Unit	mA

Object 6078h – Current Actual Value

Description	This object indicates the actual value of the current. It corresponds to the current in the motor. The value is given per thousand of rated current.
Object Type	Variable
Data Type	Integer16
Access	Read only
PDO Mapping	Yes
Default Value	0x0000
Lower Limit	0x8000
Upper Limit	0x7FFF
Unit	mA

Object 607Ah – Target Position

Description	This object indicates the commanded position that the drive should move to in position profile mode using the current settings of motion control parameters such as velocity, acceleration, deceleration, motion profile type, etc. The value of this object is interpreted as absolute or relative depending on the abs/rel flag in the controlword. It is given in user-defined position units and converted to position increments.
Object Type	Variable
Data Type	Integer32
Access	Read/Write
PDO Mapping	Yes
Default Value	0x00000000
Lower Limit	0x80000000
Upper Limit	0x7FFFFFFF
Unit	user-defined position units

Object 607Ch – Home Offset

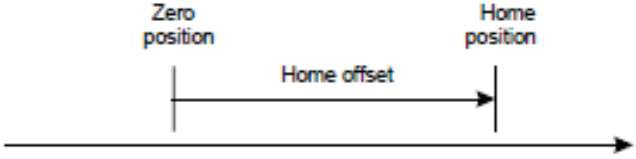
Description	<p>This object indicates the configured difference between the zero position for the application and the machine home position (found during homing). During homing, the machine home position is found and once the homing is completed, the zero position is offset from the home position by adding the home offset to the home position.</p> <p>The zero position is calculated by following equation: $zero\ position = home\ position + home\ offset$</p>  <p>All subsequent absolute moves are taken relative to this new zero position. If this object is not implemented, then the home offset is regarded as zero. The value of this object is given in user-defined position units.</p> <p>Negative values indicate the opposite direction.</p> <p>The activation of a new value of the object home offset is manufacturer-specific.</p> <p>It is recommended to apply the new value only while the drive is in homing mode.</p>
Object Type	Variable
Data Type	Integer32
Access	Read/Write
PDO Mapping	Yes
Default Value	0x00000000
Lower Limit	0x80000000
Upper Limit	0x7FFFFFFF
Unit	user-defined position units

Object 607Eh – Polarity

Description	This object indicates if the position demand value is multiplied by 1 or -1. The polarity flag has no effect on the homing mode. The position polarity bit is used only for Profile Position (PP) mode and cyclic sync position mode (CSP). The velocity polarity bit is used only for Profile Velocity (PV) mode and Cyclic Sync Velocity mode (CSV).
Object Type	Variable
Data Type	Unsigned8
Access	Read/Write
PDO Mapping	Yes
Default Value	0x0
Lower Limit	0x0
Upper Limit	0xC0

Object 607Fh – Maximum Profile Velocity

Description	This object indicates the configured maximum velocity in either direction during a profiled motion.
Object Type	Variable
Data Type	Unsigned32
Access	Read/Write
PDO Mapping	Yes
Default Value	0x0000EA60
Lower Limit	0x00000000
Upper Limit	0xFFFFFFFF

Object 6080h – Motor Maximum Speed

Description	This object indicates the configured maximum speed for the motor in either direction. It is used to protect the motor and is taken from the motor data sheet. The value is given in rotations per minute (r/min) or user-defined velocity units. <i>Not yet available.</i>
Object Type	Variable
Data Type	Unsigned32
Access	Read/Write
PDO Mapping	Yes
Default Value	0x0000
Lower Limit	0x0
Upper Limit	0xFFFFFFFF

Object 6081h – Profile Velocity in Position Profile Mode

Description	This object indicates the velocity normally attained at the end of the acceleration ramp during a profiled motion, and is valid for both directions of motion. The value is given in user-defined velocity units. The velocity units can depend on the user-defined position units.
Object Type	Variable
Data Type	Unsigned32
Access	Read/Write
PDO Mapping	Yes
Default Value	0x00000000
Lower Limit	0x00000000
Upper Limit	0xFFFFFFFF
Unit	user-defined velocity units

Object 6083h – Profile Acceleration

Description	This object indicates the configured acceleration.
Object Type	Variable
Data Type	Unsigned32
Access	Read/Write and mappable to RPDO
PDO Mapping	Yes
Default Value	0x00004E20
Lower Limit	0x00000000
Upper Limit	0xFFFFFFFF

Object 6084h – Profile Deceleration

Description	This object indicates the configured deceleration. If this parameter is not supported, then the profile acceleration object (6083h) value is also used for deceleration.
Object Type	Variable
Data Type	Unsigned32
Access	Read/Write
PDO Mapping	Yes
Default Value	0x00004E20
Lower Limit	0x00000000
Upper Limit	0xFFFFFFFF

Object 6085h – Quick Stop Deceleration

Description	This object indicates the configured deceleration used to stop the motor when the quick stop function is activated and the quick stop code object (605Ah) is set to 2 or 6. The quick stop deceleration is also used if the fault reaction code object (605Eh) is 2 and the halt option code object (605Dh) is 2.
Object Type	Variable
Data Type	Unsigned32
Access	Read/Write
PDO Mapping	Yes
Default Value	0x00000000
Lower Limit	0x00000000
Upper Limit	0xFFFFFFFF

Object 608Fh – Position Encoder Resolution

Description	This object indicates the configured encoder increments and number of motor revolutions. The position encoder resolution is calculated by the following formula: <i>position encoder resolution = encoder increments / motor revolutions</i> All values are dimensionless.
Object Type	Array
Sub-indices	3
Sub-index	0
Description	Number of entries
Object Type	Variable
Data Type	Unsigned8
Access	Read only
PDO Mapping	No
Default Value	0x00000002
Lower Limit	0x00000002
Upper Limit	0x00000002
Sub-index	1
Description	Encoder increments
Object Type	Variable
Data Type	Unsigned32
Access	Read/Write
PDO Mapping	No
Default Value	0x00002000
Lower Limit	0x00000001
Upper Limit	0xFFFFFFFF
Sub-index	2
Description	Motor revolutions
Object Type	Variable
Data Type	Unsigned32
Access	Read/Write
PDO Mapping	Yes
Default Value	0x00000001
Lower Limit	0x00000001
Upper Limit	0xFFFFFFFF

Object 6090h – Velocity Encoder Resolution

Description	This object indicates the configured encoder increments per second and the motor revolutions per second. The velocity encoder resolution is calculated by the following: $\text{velocity encoder resolution} = \frac{\text{encoder} * \frac{\text{increments}}{\text{seconds}}}{\text{motor} * \frac{\text{revolutions}}{\text{seconds}}}$ <i>Not yet available.</i>
Object Type	Array
Sub-indices	3
Sub-index	0
Description	Number of entries
Object Type	Variable
Data Type	Unsigned8
Access	Read only
PDO Mapping	No
Default Value	0x00000002
Lower Limit	0x00000002
Upper Limit	0x00000002
Sub-index	1
Description	Encoder increments per second
Object Type	Variable
Data Type	Unsigned32
Access	Read/Write
PDO Mapping	Yes
Default Value	0x00000001
Lower Limit	0x00000001
Upper Limit	0xFFFFFFFF
Sub-index	2
Description	Motor revolutions per second
Object Type	Variable
Data Type	Unsigned32
Access	Read/Write
PDO Mapping	Yes
Default Value	0x00000001
Lower Limit	0x00000001
Upper Limit	0xFFFFFFFF

Object 6091h – Fieldbus Gear Ratio

Description	This object indicates the configured number of motor shaft revolutions and number of driving shaft revolutions. The gear ratio is calculated by the following formula: <i>gear ratio = motor shaft revolutions / driving shaft revolutions</i> All values are dimensionless.
Object Type	Array
Sub-indices	3
Sub-index	0
Description	Number of entries
Object Type	Variable
Data Type	Unsigned8
Access	Read only
PDO Mapping	No
Default Value	0x00000002
Lower Limit	0x00000002
Upper Limit	0x00000002
Sub-index	1
Description	Motor revolutions
Object Type	Variable
Data Type	Unsigned32
Access	Read/Write
PDO Mapping	No
Default Value	0x00000001
Lower Limit	0x00000001
Upper Limit	0xFFFFFFFF
Sub-index	2
Description	Shaft revolutions
Object Type	Variable
Data Type	Unsigned32
Access	Read/Write
PDO Mapping	Yes
Default Value	0x00000001
Lower Limit	0x00000001
Upper Limit	0xFFFFFFFF

Object 6092h – Feed Constant

Description	This object indicates the configured feed constant, which is the measurement distance per one revolution of the driving shaft of the gearbox. The feed constant is calculated by the following formula: <i>feed constant = feed / driving shaft revolutions</i> The feed is given in user-defined position units, and the driving shaft revolution is dimensionless.
Object Type	Array
Sub-indices	3
Sub-index	0
Description	Number of entries
Object Type	Variable
Data Type	Unsigned8
Access	Read only
PDO Mapping	No
Default Value	0x00000002
Lower Limit	0x00000002
Upper Limit	0x00000002
Sub-index	1
Description	Feed (user units)
Object Type	Variable
Data Type	Unsigned32
Access	Read/Write
PDO Mapping	Yes
Default Value	0x00000001
Lower Limit	0x00000001
Upper Limit	0xFFFFFFFF
Sub-index	2
Description	Shaft revolutions
Object Type	Variable
Data Type	Unsigned32
Access	Read/Write
PDO Mapping	Yes
Default Value	0x00000001
Lower Limit	0x00000001
Upper Limit	0xFFFFFFFF

Object 6098h – Homing Method

Description	<p>This object indicates the configured homing method that will be used.</p> <p>0 = No homing method assigned 1 = Method 1 will be used ... 37 = Method 37 will be used 38 to 127 Reserved</p> <p>Refer to the CiA-402 standard for the detailed description of each homing method</p> <p>Only the following modes are supported:</p> <ul style="list-style-type: none"> • Mode 17 – homing on a negative limit switch without index pulse • Mode 18 – homing on a positive limit switch without index pulse • Mode 37 – homing on current position
Object Type	Variable
Data Type	Integer8
Access	Read/Write
PDO Mapping	No
Default Value	0x00
Lower Limit	0x80
Upper Limit	0x24

Object 6099h – Homing Speeds

Description	This object defines the speeds used during homing procedure. The values are given in user-defined velocity units.
Object Type	Array
Sub-indices	3
Sub-index	0
Description	Number of Entries
Object Type	Variable
Data Type	Unsigned8
Access	Read only
PDO Mapping	No
Default Value	0x2
Lower Limit	0x2
Upper Limit	0x2

Sub-index	1
Description	Fast Homing Speed
Object Type	Variable
Data Type	Unsigned32
Access	Read/Write
PDO Mapping	No
Default Value	0x0
Lower Limit	0x0
Upper Limit	0xFFFFFFFF
Sub-index	2
Description	Slow Homing Speed
Object Type	Variable
Data Type	Unsigned32
Access	Read/Write
PDO Mapping	No
Default Value	0x00000000
Lower Limit	0x00000000
Upper Limit	0xFFFFFFFF

Object 609Ah – Homing Acceleration

Description	This object defines the acceleration and deceleration to be used during homing operation. The value is given in user-defined acceleration unit
Object Type	Variable
Data Type	Unsigned32
Access	Read/Write
PDO Mapping	No
Default Value	0x00000000
Lower Limit	0x00000000
Upper Limit	0xFFFFFFFF
Unit	user-defined acceleration unit

Object 60C2h – Fieldbus Interpolation Time

Description	<p>This object indicates the configured interpolation cycle time. The interpolation time period (sub-index 1) value is given in $10^{(\text{interpolation time index})}$ seconds.</p> <p>The interpolation time index (sub-index 2) is dimensionless.</p> <p>This setting is essential for operation modes (object 6060h) 8, 9 and 10, for the drive internal PLL handler and the micro interpolator.</p> <p>Example:</p> $\text{InterpolationTimePeriod[s]} = 60C2h:01 * 10^{60C2h:02}$ $60C2h:01 = 0x4 = 4$ $60C2h:02 = 0xFD = -3$ $\text{InterpolationTimePeriod[s]} = 4 * 10^{-3} = 0.004 \text{ [s]} = 4 \text{ [ms]}$
Object Type	Array
Sub-indices	3
Sub-index	0
Description	Number of entries
Object Type	Variable
Data Type	Unsigned8
Access	Read only
PDO Mapping	No
Default Value	0x02
Lower Limit	0x00
Upper Limit	0xFF
Sub-index	1
Description	Interpolation time
Object Type	Variable
Data Type	Unsigned8
Access	Read/Write
PDO Mapping	Yes
Default Value	0x02
Lower Limit	0x00
Upper Limit	0xFF

Sub-index	2
Description	Interpolation time index
Object Type	Variable
Data Type	Integer8
Access	Read/Write
PDO Mapping	Yes
Default Value	0xFD
Lower Limit	0x80
Upper Limit	0x3F

Object 60C5h – Maximum Acceleration

Description	The maximum acceleration. It is used to limit the acceleration to an acceptable value in order to prevent the motor and the moved mechanics from being damaged. <i>Not yet available.</i>
Object Type	Variable
Data Type	Integer32
Access	Read/Write
PDO Mapping	Yes
Default Value	0x00000000
Lower Limit	0x00000000
Upper Limit	0xFFFFFFFF

Object 60C6h – Maximum Deceleration

Description	The maximum deceleration. It is used to limit the deceleration to an acceptable value in order to prevent the motor and the moved mechanics from being damaged. <i>Not yet available.</i>
Object Type	Variable
Data Type	Integer32
Access	Read/Write
PDO Mapping	Yes
Default Value	–
Lower Limit	0x00000000
Upper Limit	0xFFFFFFFF

Object 60FFh – Target Velocity

Description	This object indicates the configured target velocity and is used as input for the trajectory generator.
Object Type	Variable
Data Type	Integer32
Access	Read/Write and mappable to RPDO
PDO Mapping	Yes
Default Value	0x00000000
Lower Limit	0x80000000
Upper Limit	0x7FFFFFFF
Unit	CAN user-defined velocity

Object 6502h – Supported Drive Modes

Description	This object contains information about the supported drive modes.
Object Type	Variable
Data Type	Unsigned32
Access	Read only
PDO Mapping	No
Default Value	–
Lower Limit	0x00000000
Upper Limit	0xFFFFFFFF

8 Units

8.1 Units Overview

CiA standards provide two objects for setting the gear ratio and the feed constant conversion factors, each of which has two sub-indices, as shown in the following table.

CAN Object	Description
6092h, sub-index 1	Feed Constant (numerator) – Feed user units
6092h, sub-index 2	Feed Constant (denominator) – Shaft revolutions
6091h, sub-index 1	Fieldbus Gear Ratio – Motor revolutions
6091h, sub-index 2	Fieldbus Gear Ratio – Drive shaft revolutions

You can modify the values by writing directly to the objects.

8.2 Position Unit Conversion

CAN standards define the position as [*user counts / driving shaft*].

User counts represents the application, such as [mm], [rad], [deg], and the driving shaft is basically the output of a gearbox.

Assuming that the position loop of the drive works with encoder-increments as a unit, the following objects are used in unit conversions:

CAN Object	Description
608Fh – Position Encoder Resolution	The configured encoder increments and number of motor revolutions. <i>position encoder resolution = encoder increments / motor revolutions</i>
6091h – Fieldbus Gear Ratio	The configured number of motor shaft revolutions and number of driving shaft revolutions. <i>gear ratio = motor shaft revolutions / driving shaft revolutions</i>
6092h – Feed Constant	The configured feed constant, which is the measurement distance per one revolution of the driving shaft of the gearbox. <i>feed constant = feed / driving shaft revolutions</i>

The conversion from CAN user units to internal motor encoder increments is as follows:

$$x \text{ [CAN user unit]} = \frac{x * \frac{6091\text{h:01}}{6091\text{h:02}} * \frac{608\text{Fh:01}}{6092\text{h:01}}}{\frac{608\text{Fh:01}}{6092\text{h:02}}} \text{ [encoder increments]}$$

The conversion from internal motor encoder increments to CAN user units (e.g. for representing the actual position in object 6064h) is as follows:

$$x \text{ [encoder increments]} = \frac{x * \frac{6092\text{h:01}}{6092\text{h:02}}}{\frac{6091\text{h:01}}{6091\text{h:02}} * \frac{608\text{Fh:01}}{608\text{Fh:01}}} \text{ [CAN user unit]}$$

Example

Let's assume you want to have a user unit of [mm]. The application moves 200 [mm] per gearbox revolution and the gearbox ratio is 2:1.

Furthermore, an encoder connected to the motor generates 4096 [increments/motor-rev].

The CAN object settings must be as follows:

```
608Fh:01 = 4096
608Fh:02 = 1

6091h:01 = 2
6091h:02 = 1

6092h:01 = 200
6092h:02 = 1
```

You can now issue a position command in [mm] using object 607Ah, in Profile Position mode, for example.

8.3 Velocity Unit Conversion

According to CiA standards, CAN object 60A9h represents the user-defined velocity units. If object 60A9h is not implemented, the velocity is defined as [CAN user position units / second].

Object 60A9h is not implemented in the servSD/servIM.

Example

Let's assume you want to have a user unit of [mm]. The application moves 200 [mm] per gearbox revolution and the gearbox ratio is 2:1.

Let's assume you want to use the unit [rpm], which means that 1 [rps] represents 60 [rpm]. Let's also assume there is no gearbox connected to the motor.

The CAN object settings must be as follows:

608Fh:01 = 4096

608Fh:02 = 1

6091h:01 = 1

6091h:02 = 1

6092h:01 = 60

6092h:02 = 1

You can now issue a velocity command in [rpm] using object 60FFh, in Profile Velocity mode, for example.

8.4 Acceleration/Deceleration Unit Conversion

According to CiA standards, CAN object 60AAh represents the user-defined acceleration units. If object 60AAh is not implemented, the acceleration is defined as $[CAN\ user\ velocity\ units / second] = [CAN\ user\ position\ units / second^2]$

Object 0x60AA is not implemented in the servSD/servIM.

Example

Let's assume you want to use the unit [rpm/s], which means that 1 [rps] represents 60 [rpm]. Let's also assume there is no gearbox connected to the motor.

Furthermore, an encoder connected to the motor generates 4096 [increments / motor-rev].

The CAN object settings must be as follows:

0x608F:01 = 4096

0x608F:02 = 1

0x6091:01 = 1

0x6091:02 = 1

0x6092:01 = 60

0x6092:02 = 1

You can now set the acceleration/deceleration in unit [rpm/s] using object 6083h or 6084h, in Profile Velocity mode, for example.

CANopen
for servSD | servIM
User Manual