

PRH02 *Series*

High-Performance Permanent Magnet Synchronous Servo Motor

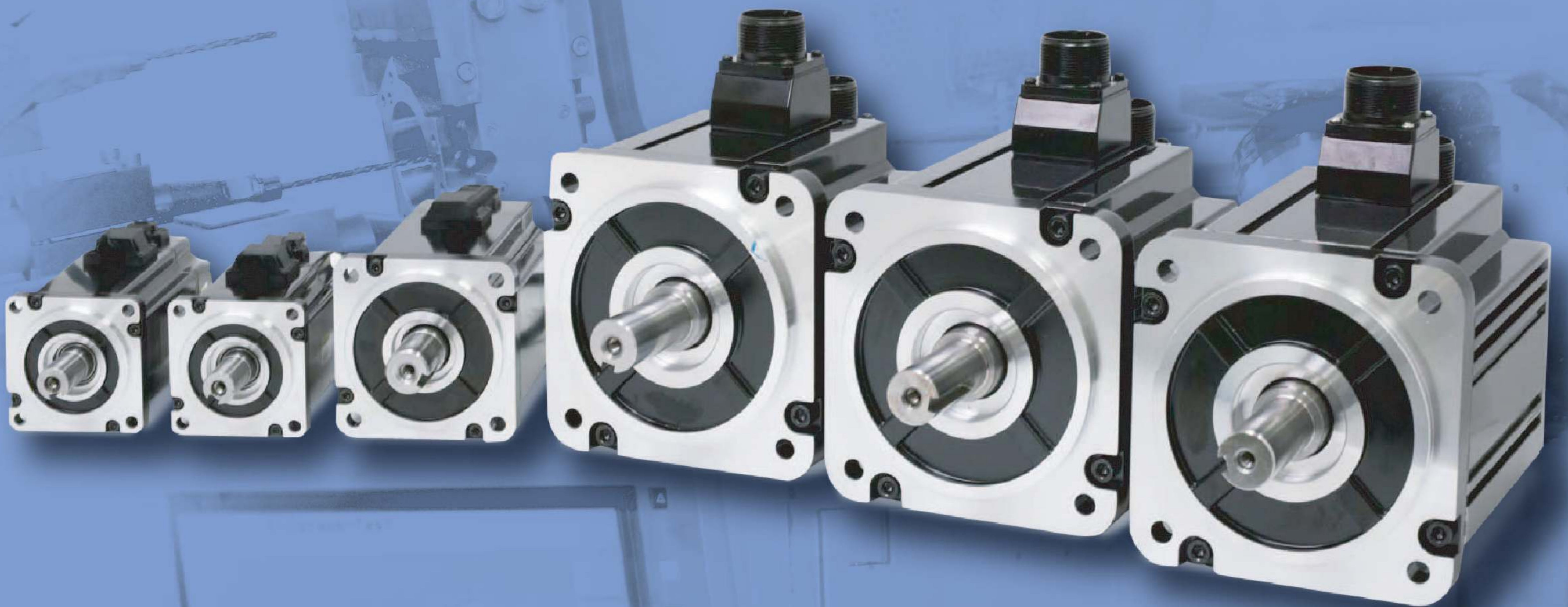

High-Performance Permanent Magnet Synchronous Servo Motor PRHD2

Servotronix Motion Control Ltd. introduced the PRHD2 series high-performance permanent magnet synchronous servo motors, aiming to meet the requirements of intelligent manufacturing equipment and future industrial 4.0 applications.

PRHD2 series servo motors are independently designed and manufactured by Servotronix company to cooperate with servo drives, such as CDHD, CDHD2, BDHD2, DDHD and BDHDE. This series of motors is equipped with a short sensAR 20bit absolute encoder and an optional Tamagawa absolute encoder, which has the characteristics of high speed, high precision, high overload and high dynamic response.

Compared with the previous generation, the PRHD2 series servo motor adopts brand-new electromagnetic design, which has the characteristics of compact structure, high power density, high efficiency, low temperature rise, small torque ripple, small cogging torque and complete product models.

The perfect combination of Servotronix servo motor and drive can reliably monitor and dynamically respond to actual position, speed and temperature in real time. The complete combination of PRHD2 servo units ensures the accuracy and smoothness required for automatic precision machining (such as robot manufacturing, machining and electronic product assembly).

Customers can easily and quickly do commissioning on PRHD2 bundle, but are not limited to predefined options. PRHD2 could be paired with drives or encoders selected by customers for their application.

PRHD2 Features and Advantages

Permanent magnet synchronous AC servo motor
Flange size: 40-60-80-100-130-180 mm
Rated torque: 0.16Nm-48Nm
Rated power: 50W-7.5kW
Maximum speed: 6000r/min
Low cogging
Low temperature rise during operation
High overload capacity
Built-in self-developed 20bit magnetic absolute encoder
Tamagawa 17bit and 23bit photoelectric absolute encoder
Insulation class: F (155°C)
IP65 Standard - IP67 Option
Ambient operation temperature: -10°C~+40°C.
Optional holding brake
Optional oil seal
CE,UL,RoHS,REACH

CE **cUL[®]US** **RoHS** **REACH** ✓

PRHD2 Series Servo Motor

Technical Product Information -220VAC

Motor Model	Rated Power [W]	Rated Torque [Nm]	Rated Speed [rpm]	Rated Current [A]	Rotational Inertia [$\times 10^{-4} \text{kg.m}^2$]
PH2-L04A230	50	0.16/0.56	3000/6000	0.9/3.3	0.02/0.027
PH2-L04B230	100	0.32/1.12	3000/6000	0.85/2.9	0.035/0.042
PH2-M04A230	50	0.16/0.56	3000/6000	0.45/1.6	0.041/0.048
PH2-M04B230	100	0.32/1.12	3000/6000	0.9/3.1	0.075/0.082
PH2-L06A230	200	0.64/2.24	3000/6000	1.5/5.7	0.14/0.147
PH2-L06B230	400	1.27/4.46	3000/6000	2.9/11.2	0.23/0.236
PH2-M06A230	200	0.64/2.24	3000/6000	1.7/6.1	0.27/0.29
PH2-M06B230	400	1.27/4.46	3000/6000	2.8/10.2	0.49/0.51
PH2-L08A230	750	2.39/8.36	3000/6000	4.5/16.6	0.791/0.861
PH2-M08A230	750	2.39/8.36	3000/6000	5/18.1	1.72/1.74
PH2-L10A230	1000	3.18/9.54	3000/5000	6/20.5	2.23/2.57
PH2-L10B230	1500	4.78/14.34	3000/5000	10/34.2	3.14/3.48
PH2-L10C230	2000	6.37/19.11	3000/5000	12/37.3	4.17/4.51
PH2-M13A215	1000	6.37/19.1	1500/2000	5.6/16.8	8.45/8.6
PH2-M13B215	1500	9.55/28.65	1500/2000	8.7/26.1	12.32/12.5
PH2-M13B220	2000	9.55/28.65	2000/3000	12.7/38.1	12.97/13.16
PH2-M13C220	1100	5.39/16.17	2000/3000	7.5/21	12.5/14.5
PH2-M13D220	1750	8.34/25.02	2000/3000	11.5/33	18.5/20.5
PH2-M13E220	2400	11.5/34.5	2000/3000	15.6/45	24.2/26.2
PH2-M18A215	3000	19.1/47.75	1500/3000	23/58.67	42.4/49.4
PH2-M18B215	4500	28.6/71.5	1500/3000	33.5/85.46	62.3/69.3
PH2-M18C215	5500	35/87.5	1500/3000	42/107.14	84.1/91.1
PH2-M18D215	7500	48/120	1500/3000	55.1/140.56	122/129

PRHD2 Series Servo Motor

Technical Product Information -440VAC

Motor Model	Rated Power [W]	Rated Torque [Nm]	Rated Speed [rpm]	Rated Current [A]	Rotational Inertia [$\times 10^{-4}$kg.m²]
PH2-L10A430	1000	3.18/9.54	3000/5000	3/9	2.23/2.57
PH2-L10B430	1500	4.78/14.34	3000/5000	5/18	3.14/3.48
PH2-L10C430	2000	6.37/19.11	3000/5000	6/18	4.17/4.51
PH2-M13C420	1100	5.39/16.17	2000/3000	3.8/11.4	12.5/14.5
PH2- M13D420	1750	8.34/25.02	2000/3000	5.4/16	18.5/20.5
PH2-M13E420	2400	11.5/34.5	2000/3000	8.1/24	24.2/26.2
PH2-M18A415	3000	19.1/47.75	1500/3000	11.8/30	42.4/49.4
PH2-M18B415	4500	28.6/71.5	1500/3000	18.5/47	62.3/69.3
PH2-M18C415	5500	35/87.5	1500/3000	22.4/57.2	84.1/91.1
PH2-M18D415	7500	48/120	1500/3000	29/74	122/129

PRHD2 Series Synchronous Servo Motor

Ordering Information

	PH2	—	M	04	A	2	30	0	5	S3	0	D
PRHD2 Series Synchronous Servo Motor												
Inertia												
L	Low inertia											
M	Medium inertia											
Flange												
04	40 mm											
06	60 mm											
08	80 mm											
10	100 mm											
13	130 mm											
18	180 mm											
Model												
A	Type A											
B	Type B											
C	Type C											
D	Type D											
E	Type E											
Bus voltage												
2	230VC											
4	400VC											
Rated Speed												
10	1000 rpm											
15	1500 rpm											
20	2000 rpm											
30	3000 rpm											
Shaft End & Oil Seal												
0	Optical axis											
1	Optical axis with oil seal											
2	With key											
3	With key and oil seal											
IP class												
5	IP65											
Compilers												
S3	SensAR Single-turn Absolute Encoder 20-bit											
M3	SensAR Multi-turn Absolute Encoder 20-bit											
T4	Tamagawa Multi-turn Absolute Encoder 23-bit											
Brake												
0	No brake											
1	With brake											
Connector												
D	AMP connector											
A	MIL connector											

PRHD2 40

220VAC Specifications

TIME RATING
INSULATION CLASS
ENCLOSURE
PROTECTION CLASS

Continuous
F
Totally enclosed. Self-cooled
IP65

AMBIENT TEMPERATURE
RELATIVE HUMIDITY
NUMBER OF POLES
CERTIFICATION

-10 ... + 40 °C
20 ... 80%
10
CE/UL

			<i>PH2-L04A230</i>	<i>PH2-L04B230</i>
Rated torque	M_n	Nm	0.16	0.32
Peak torque	T_{max}	Nm	0.56	1.12
Rated Speed	nN	min ⁻¹	3000	3000
Maximum speed	n_{max}	min ⁻¹	6000	6000
Rated power	P_N	kW	0.05	0.1
Rated current	I_N	A_{rms}	0.9	0.85
Maximum current	I_{max}	A_{rms}	3.3	2.9
Continuous locked-rotor torque	T_o	Nm	0.176	0.352
Continuous locked-rotor current	I_o	A_{rms}	1.045	0.935
Rated voltage	Un	V_{AC}	220	220
Maximum winding voltage	U_{max}	V_{DC}	340	340
Maximum voltage to ground		V_{AC}	240	240
Voltage constant	K_{eu-v}	V_{rms}/k_{rpm}	11.9	26.1
Torque constant	K_t	N.m/ A_{rms}	0.18	0.39
Winding resistance	$R_{20\ u-v}$	Ω	13.5	24.5
Winding inductance	L_{u-v}	mH	12.9	26.7
Rotor inertia (without brake)	J_M	$\times 10^{-4}$ kg.m ²	0.02	0.035
Rotor inertia (with brake)	J_M	$\times 10^{-4}$ kg.m ²	0.027	0.042
Mass (without brake)	m	Kg	0.46	0.59
Mass (with brake)	m	Kg	0.66	0.79
Thermal time constant		min ⁻¹	7	9
Maximum radial shaft load		N	78	78
Maximum axial shaft load		N	54	54

PRHD2 40

220VAC Torque and Speed Charts

PH2-L04A230

PH2-L04B230

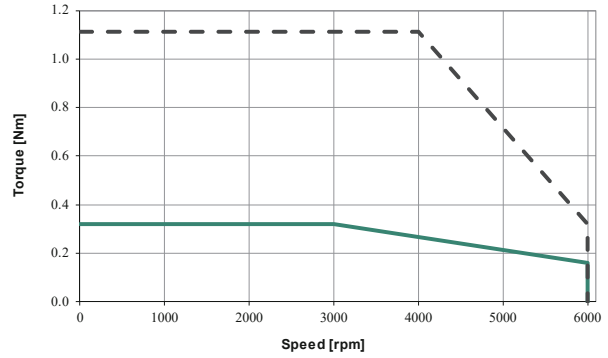
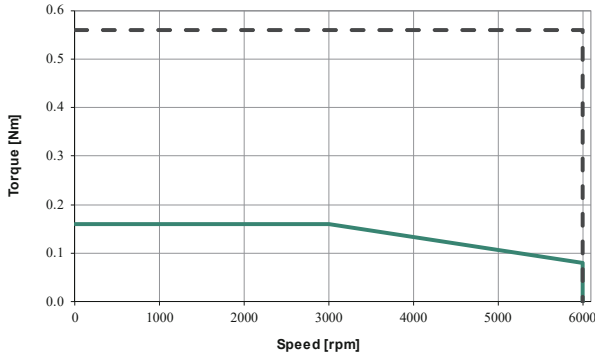

— Continuous torque
- - - Peak operation

PRHD2 40 220VAC Overall Dimensions

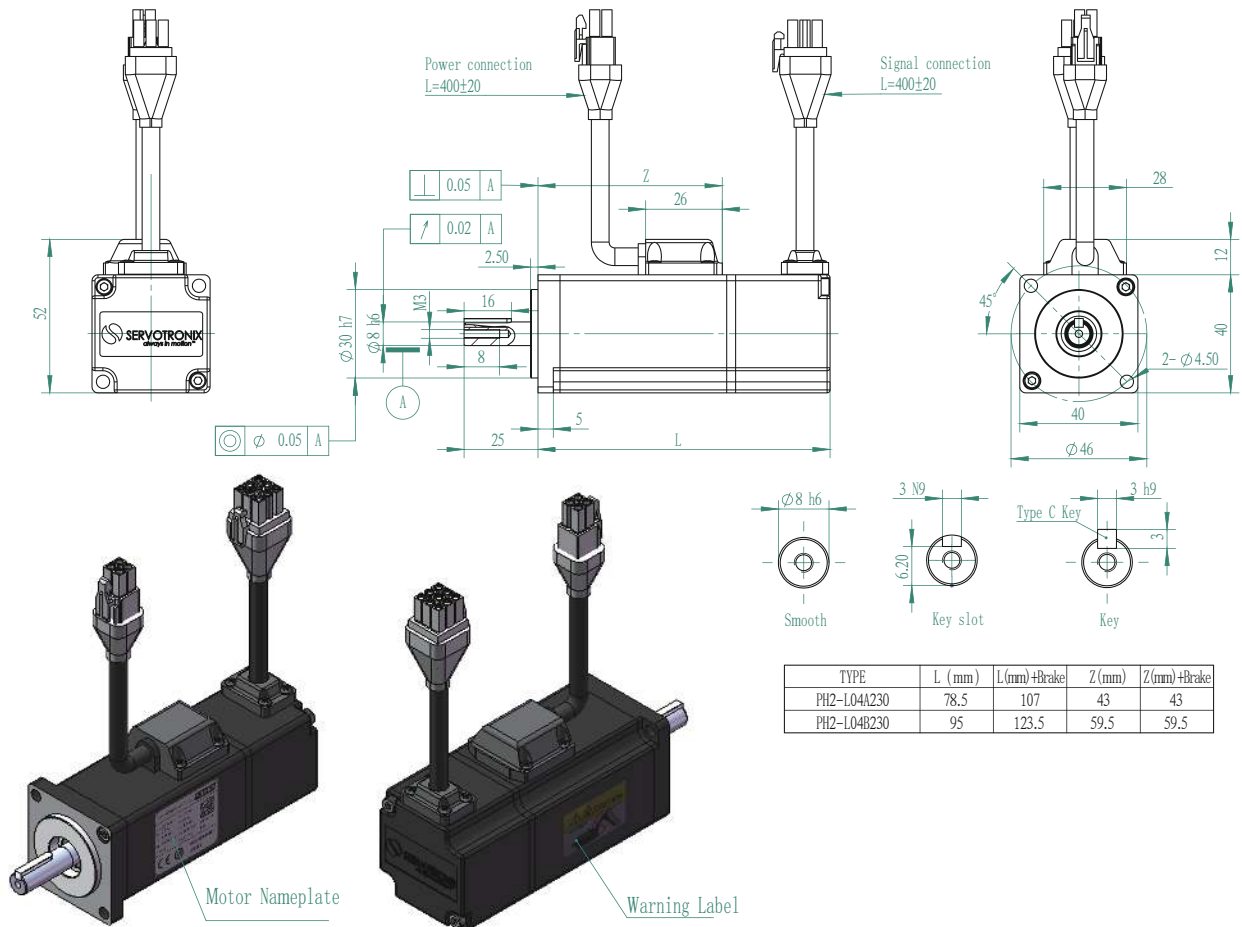

PRHD2 40

220VAC Specifications

TIME RATING
INSULATION CLASS
ENCLOSURE
PROTECTION CLASS

Continuous
F
Totally enclosed. Self-cooled
IP65

AMBIENT TEMPERATURE
RELATIVE HUMIDITY
NUMBER OF POLES
CERTIFICATION

-10 ... + 40 °C
20 ... 80%
10
CE/UL

			<i>PH2-M04A230</i>	<i>PH2-M04B230</i>
Rated torque	M_n	Nm	0.16	0.32
Peak torque	T_{max}	Nm	0.56	1.12
Rated Speed	nN	min ⁻¹	3000	3000
Maximum speed	n_{max}	min ⁻¹	6000	6000
Rated power	P_N	kW	0.05	0.1
Rated current	I_N	A_{rms}	0.45	0.9
Maximum current	I_{max}	A_{rms}	1.6	3.1
Continuous locked-rotor torque	T_o	Nm	0.176	0.352
Continuous locked-rotor current	I_o	A_{rms}	0.495	0.99
Rated voltage	Un	V_{AC}	220	220
Maximum winding voltage	U_{max}	V_{DC}	340	340
Maximum voltage to ground		V_{AC}	240	240
Voltage constant	K_{eu-v}	V_{rms}/k_{rpm}	23.7	23.7
Torque constant	K_t	N.m/ A_{rms}	0.39	0.39
Winding resistance	$R_{20\ u-v}$	Ω	44	17.5
Winding inductance	L_{u-v}	mH	21.75	9.55
Rotor inertia (without brake)	J_M	$\times 10^{-4}$ kg.m ²	0.041	0.075
Rotor inertia (with brake)	J_M	$\times 10^{-4}$ kg.m ²	0.048	0.082
Mass (without brake)	m	Kg	0.45	0.55
Mass (with brake)	m	Kg	0.65	0.75
Thermal time constant		min ⁻¹	7	9
Maximum radial shaft load		N	78	78
Maximum axial shaft load		N	54	54

PRHD2 40

220VAC Torque and Speed Charts

PH2-M04A230

PH2-M04B230

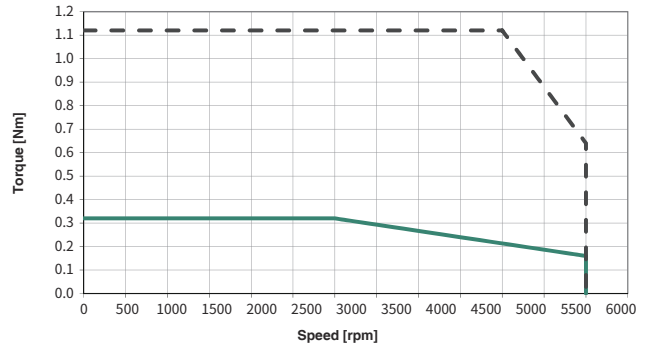
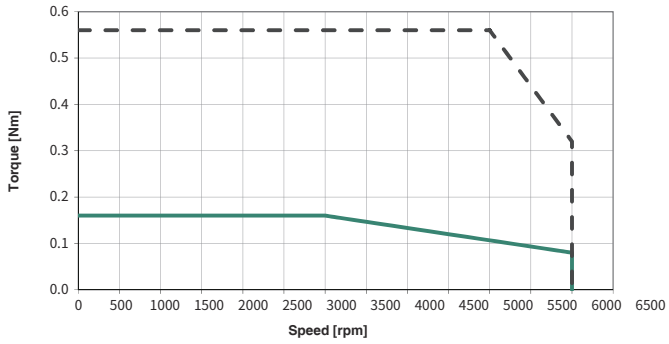

— Continuous torque
- - - Peak operation

PRHD2 40 220VAC Overall Dimensions

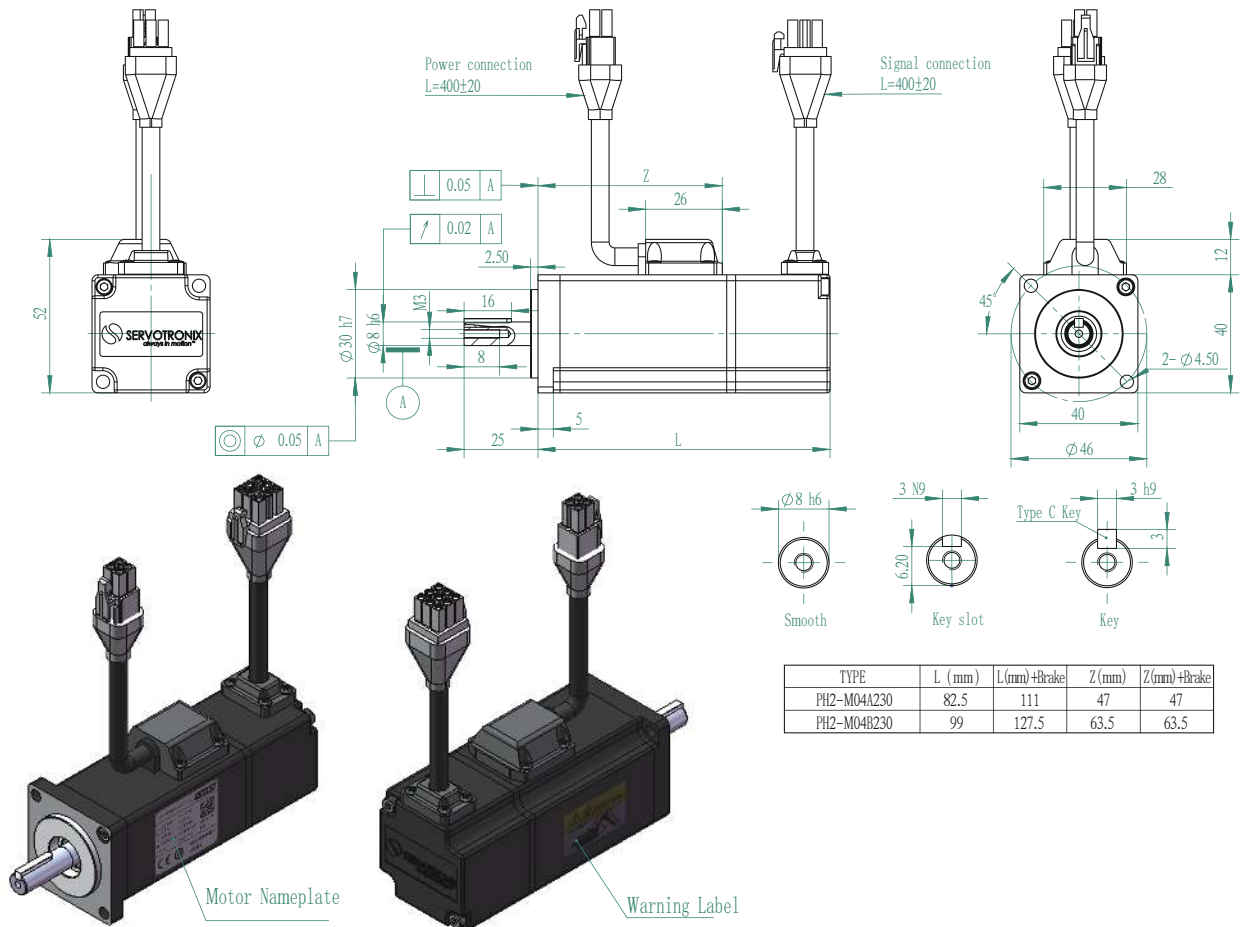

PRHD2 60

220VAC Specifications

TIME RATING
INSULATION CLASS
ENCLOSURE
PROTECTION CLASS

Continuous
F
Totally enclosed. Self-cooled
IP65

AMBIENT TEMPERATURE
RELATIVE HUMIDITY
NUMBER OF POLES
CERTIFICATION

-10 ... + 40 °C
20 ... 80%
10
CE/UL

			<i>PH2-L06A230</i>	<i>PH2-M04B230</i>
Rated torque	M_n	Nm	0.64	1.27
Peak torque	T_{max}	Nm	2.24	4.46
Rated Speed	nN	min ⁻¹	3000	3000
Maximum speed	n_{max}	min ⁻¹	6000	6000
Rated power	P_N	kW	0.2	0.4
Rated current	I_N	A_{rms}	1.5	2.9
Maximum current	I_{max}	A_{rms}	5.7	11.2
Continuous locked-rotor torque	T_o	Nm	0.704	1.397
Continuous locked-rotor current	I_o	A_{rms}	1.65	3.19
Rated voltage	Un	V_{AC}	220	220
Maximum winding voltage	U_{max}	V_{DC}	340	340
Maximum voltage to ground		V_{AC}	240	240
Voltage constant	K_{eu-v}	V_{rms}/k_{rpm}	27.5	28
Torque constant	K_t	N.m/ A_{rms}	0.454	0.46
Winding resistance	$R_{20\ u-v}$	Ω	6.82	2.79
Winding inductance	L_{u-v}	mH	16	8.2
Rotor inertia (without brake)	J_M	$\times 10^{-4}$ kg.m ²	0.14	0.23
Rotor inertia (with brake)	J_M	$\times 10^{-4}$ kg.m ²	0.147	0.236
Mass (without brake)	m	Kg	1.1	1.5
Mass (with brake)	m	Kg	1.7	2.1
Thermal time constant		min ⁻¹	10	12
Maximum radial shaft load		N	245	245
Maximum axial shaft load		N	75	75

PRHD2 60

220VAC Torque and Speed Charts

PH2-L06A230

PH2-L06B230

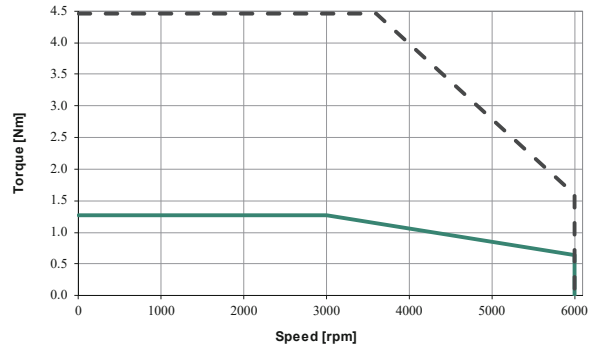
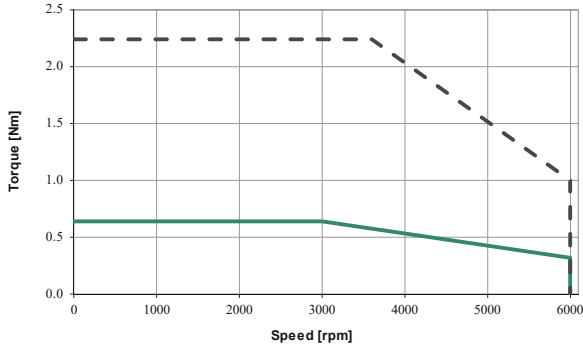

— Continuous torque
- - - Peak operation

PRHD2 60 220VAC Overall Dimensions

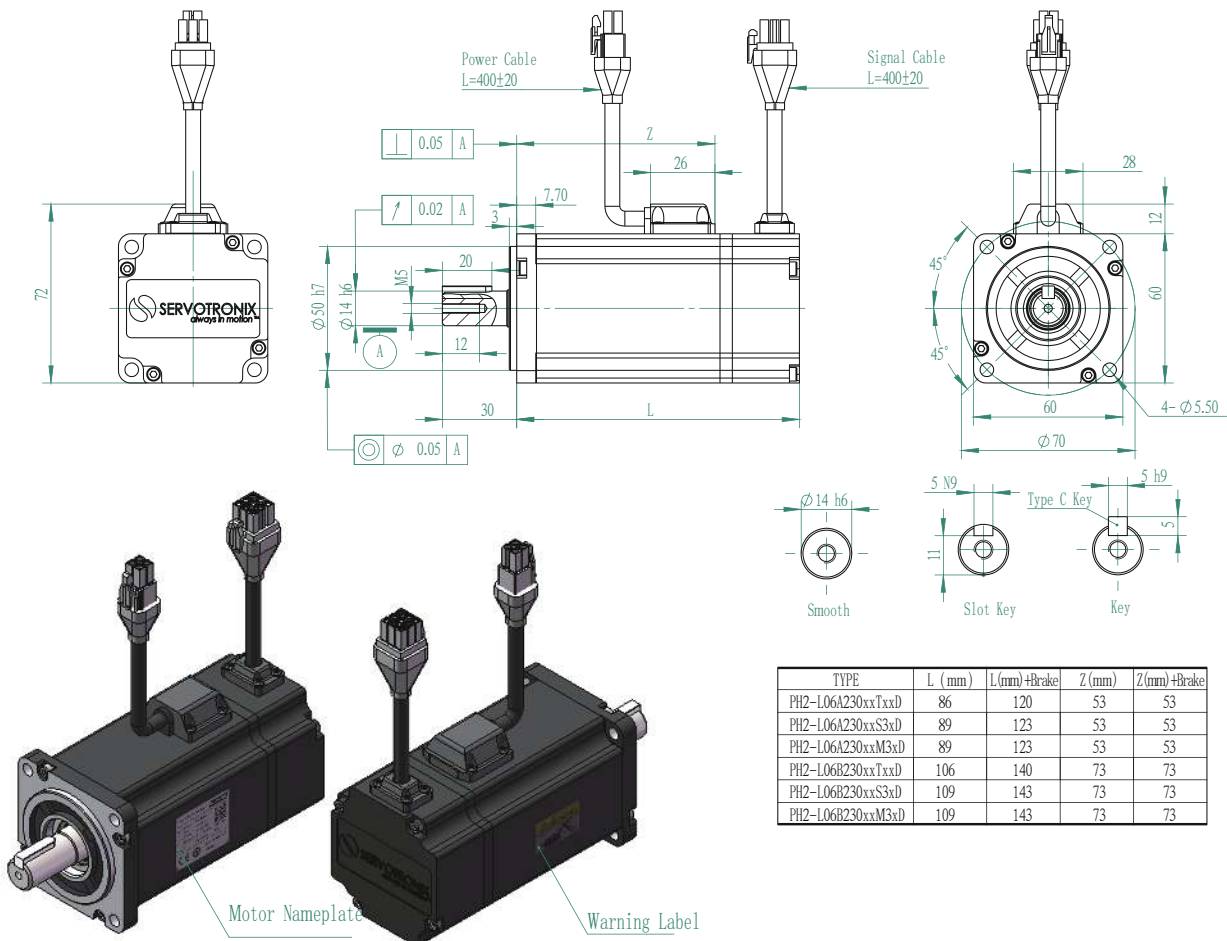

TYPE	L (mm)	L(mm)+Brake	Z (mm)	Z(mm)+Brake
PH2-L06A230xxxTxxD	86	120	53	53
PH2-L06A230xxxS3xD	89	123	53	53
PH2-L06A230xxxM3xD	89	123	53	53
PH2-L06B230xxxTxxD	106	140	73	73
PH2-L06B230xxxS3xD	109	143	73	73
PH2-L06B230xxxM3xD	109	143	73	73

PRHD2 60

220VAC Specifications

TIME RATING
INSULATION CLASS
ENCLOSURE
PROTECTION CLASS

Continuous
F
Totally enclosed. Self-cooled
IP65

AMBIENT TEMPERATURE
RELATIVE HUMIDITY
NUMBER OF POLES
CERTIFICATION

-10 ... + 40 °C
20 ... 80%
10
CE/UL

			<i>PH2-M06A230</i>	<i>PH2-M06B230</i>
Rated torque	M_n	Nm	0.64	1.27
Peak torque	T_{max}	Nm	2.24	4.46
Rated Speed	nN	min ⁻¹	3000	3000
Maximum speed	n_{max}	min ⁻¹	6000	6000
Rated power	P_N	kW	0.2	0.4
Rated current	I_N	A_{rms}	1.7	2.8
Maximum current	I_{max}	A_{rms}	6.1	10.2
Continuous locked-rotor torque	T_o	Nm	0.704	1.397
Continuous locked-rotor current	I_o	A_{rms}	1.87	3.08
Rated voltage	Un	V_{AC}	220	220
Maximum winding voltage	U_{max}	V_{DC}	340	340
Maximum voltage to ground		V_{AC}	240	240
Voltage constant	K_{eu-v}	V_{rms}/k_{rpm}	25	29.86
Torque constant	K_t	N.m/ A_{rms}	0.38	0.49
Winding resistance	$R_{20\ u-v}$	Ω	4.25	2.62
Winding inductance	L_{u-v}	mH	9.2	6.2
Rotor inertia (without brake)	J_M	$\times 10^{-4}$ kg.m ²	0.27	0.49
Rotor inertia (with brake)	J_M	$\times 10^{-4}$ kg.m ²	0.29	0.51
Mass (without brake)	m	Kg	1.1	1.6
Mass (with brake)	m	Kg	1.5	2.1
Thermal time constant		min ⁻¹	8	10
Maximum radial shaft load		N	245	245
Maximum axial shaft load		N	75	75

PRHD2 60

220VAC Torque and Speed Charts

PH2-M06A230

PH2-M06B230

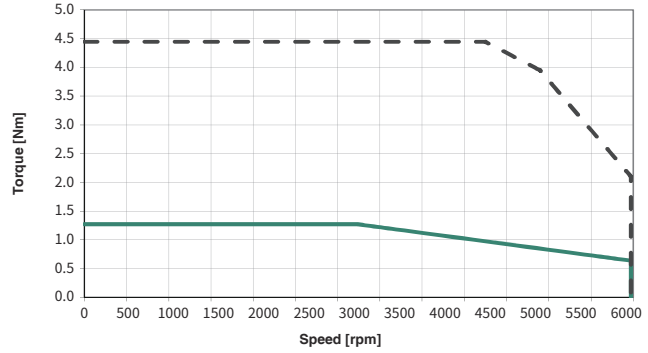
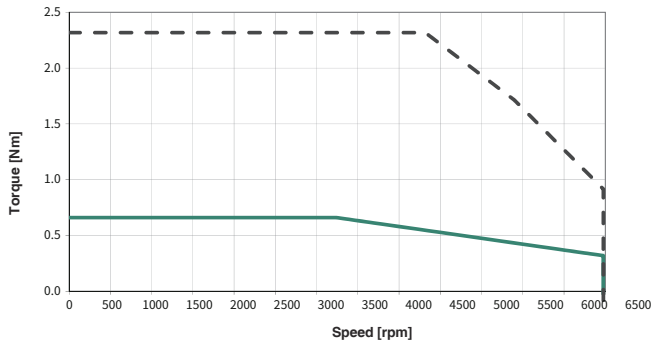

— Continuous torque
- - - Peak operation

PRHD2 60 220VAC Overall Dimensions

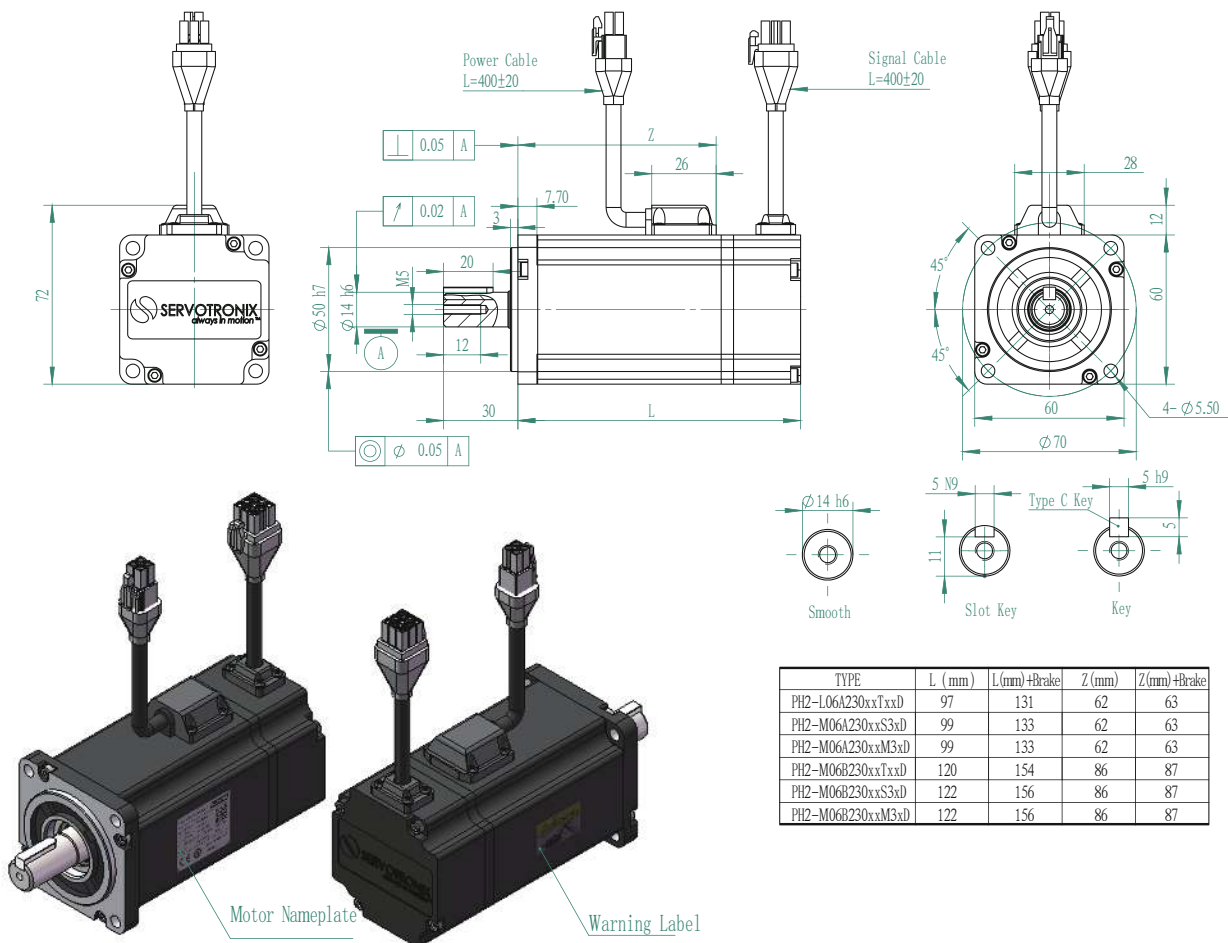

Motor SIZE 60

220VAC Specifications

TIME RATING
PROTECTION CLASS
ENCLOSURE
MOUNTING METHOD

Continuous
IP65
Totally enclosed. Self-cooled
IMB5(IMV1,IMV3)

AMBIENT TEMPERATURE
RELATIVE HUMIDITY
NUMBER OF POLES

-10 ... + 40 °C
10 ... 90%
10

			<i>PH2-NO6A230</i>	<i>PH2-N06B230</i>
Rated torque	M_n	Nm	0.637	1.27
Peak torque	T_{max}	Nm	2.24	4.06*1
Rated Speed	nN	min ⁻¹	3000	3000
Maximum speed	n_{max}	min ⁻¹	6500	6500
Rated power	P_N	kW	0.2	0.4
Rated current	I_N	A_{rms}	1.5	2,4
Maximum current	I_{max}	A_{rms}	5.7	8.4
Rated voltage	Un	V_{AC}	220	220
Maximum winding voltage	U_{max}	V_{DC}	340	340
Maximum voltage to ground		V_{AC}	240	240
Voltage constant	K_{eu-v}	V_{rms}/k_{rpm}	27.5	34.8
Torque constant	K_t	N.m/ A_{rms}	0.454	0.57
Winding resistance	$R_{20 u-v}$	Ω	6.82	4.1
Winding inductance	L_{u-v}	mH	16	12.8
Rotor inertia (without brake)	J_M	$\times 10^{-4} \text{ kg.m}^2$	0.14	0.23
Rotor inertia (with brake)	J_M	$\times 10^{-4} \text{ kg.m}^2$	0.151	0.241
Mass (without brake)	m	Kg	1.1	1.5
Mass (with brake)	m	Kg	1.6	2.0
Thermal time constant		min ⁻¹	10	12
Maximum radial shaft load		N	245	245
Maximum axial shaft load		N	75	75

Motor SIZE 60

220VAC Torque and Speed Charts

PH2-NO6A230

PH2-N06B230

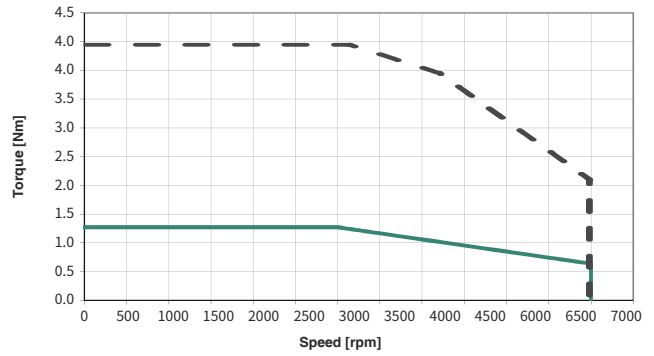
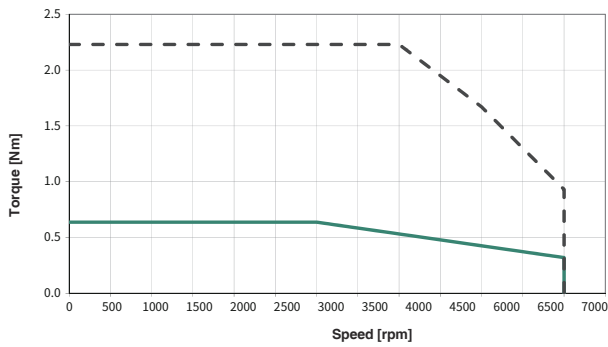

— Continuous torque
- - - Peak operation

Motor SIZE 60 220VAC Overall Dimensions

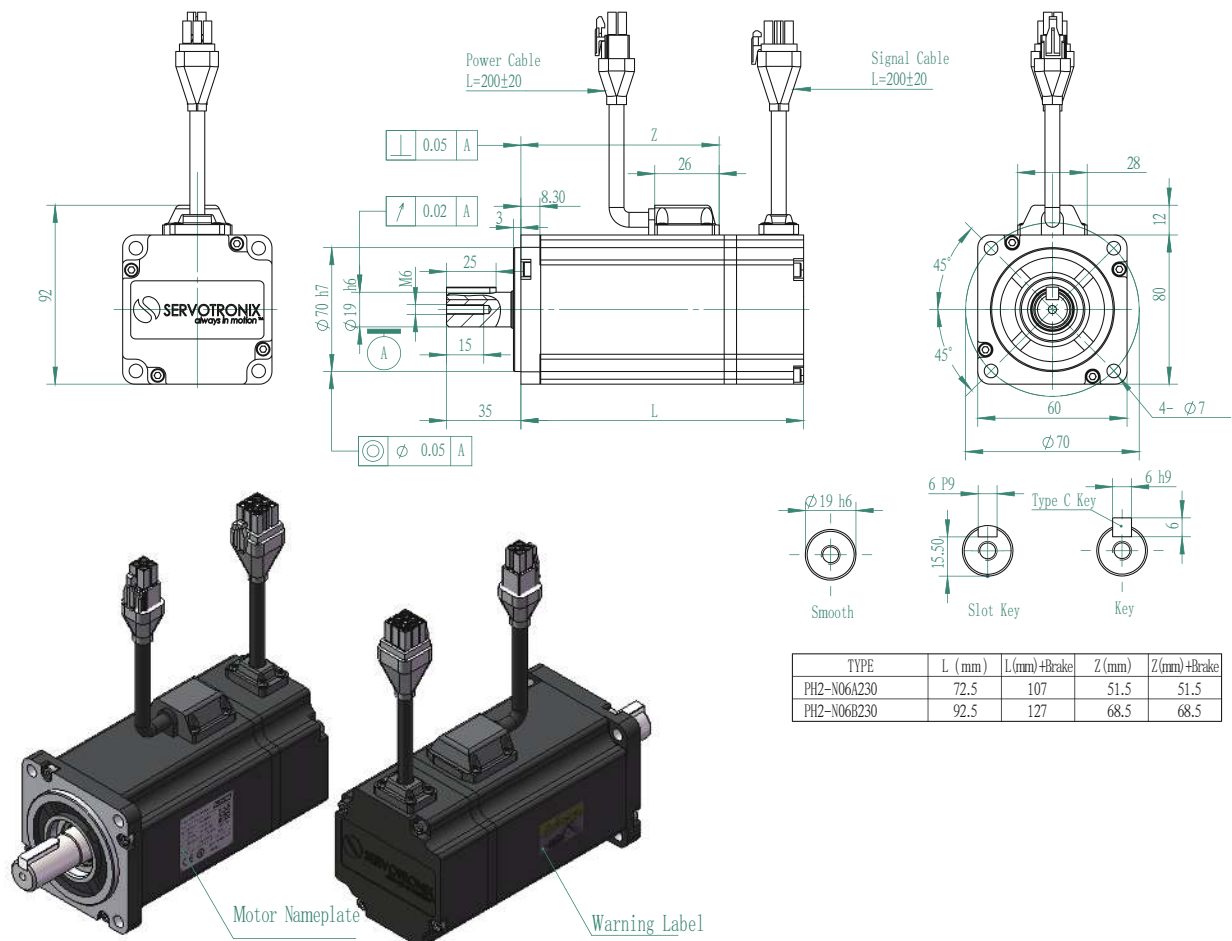

Motor SIZE 80

220VAC Specifications

TIME RATING	Continuous	AMBIENT TEMPERATURE	-10 ... + 40 °C
PROTECTION CLASS	IP65	RELATIVE HUMIDITY	10 ... 90%
ENCLOSURE	Totally enclosed. Self-cooled	NUMBER OF POLES	10
MOUNTING METHOD	IMB5(IMV1,IMV3)		

			PH2-N08A230
Rated torque	M_n	Nm	2.39
Peak torque	T_{max}	Nm	2.39
Rated Speed	nN	min ⁻¹	3000
Maximum speed	n_{max}	min ⁻¹	6500
Rated power	P_N	kW	0.75
Rated current	I_N	A_{rms}	4.5
Maximum current	I_{max}	A_{rms}	16.6
Rated voltage	Un	V_{AC}	220
Maximum winding voltage	U_{max}	V_{DC}	340
Maximum voltage to ground		V_{AC}	240
Voltage constant	K_{eu-v}	V_{rms}/k_{rpm}	36.1
Torque constant	K_t	N.m/ A_{rms}	0.53
Winding resistance	$R_{20 u-v}$	Ω	1.33
Winding inductance	L_{u-v}	mH	8.1
Rotor inertia (without brake)	J_M	$\times 10^{-4} \text{ kg.m}^2$	0.791
Rotor inertia (with brake)	J_M	$\times 10^{-4} \text{ kg.m}^2$	0.828
Mass (without brake)	m	Kg	2.3
Mass (with brake)	m	Kg	2.9
Thermal time constant		min ⁻¹	15
Maximum radial shaft load		N	392
Maximum axial shaft load		N	147

Motor SIZE 80

220VAC Torque and Speed Charts

PH2-N08A230

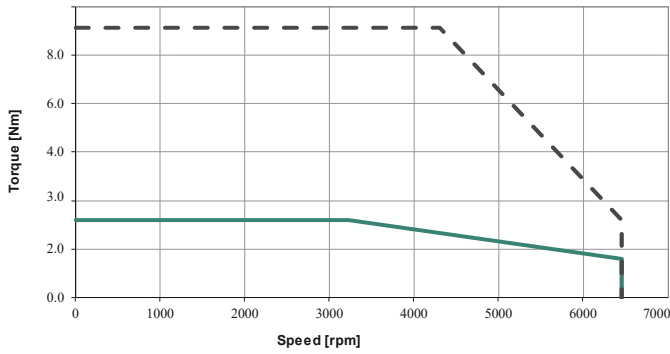

——— Continuous torque
- - - - - Peak operation

Motor SIZE 80 220VAC Overall Dimensions

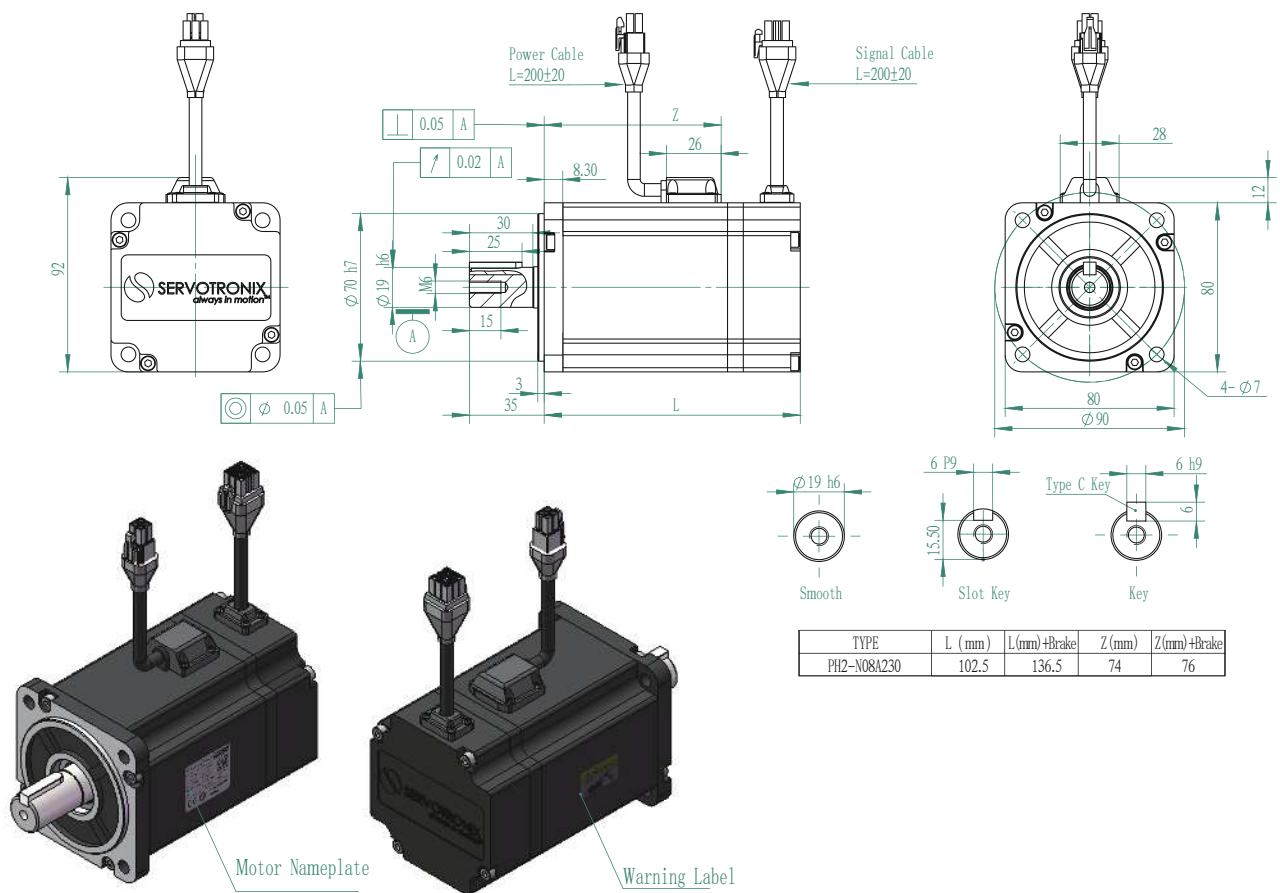

PRHD2 80

220VAC Specifications

TIME RATING
INSULATION CLASS
ENCLOSURE
PROTECTION CLASS

Continuous
F
Totally enclosed. Self-cooled
IP65

AMBIENT TEMPERATURE
RELATIVE HUMIDITY
NUMBER OF POLES
CERTIFICATION

-10 ... + 40 °C
20 ... 80%
10
CE/UL

			PH2-L08A230
Rated torque	M_n	Nm	2.39
Peak torque	T_{max}	Nm	8.36
Rated Speed	nN	min ⁻¹	3000
Maximum speed	n_{max}	min ⁻¹	6000
Rated power	P_N	kW	0.75
Rated current	I_N	A_{rms}	4.5
Maximum current	I_{max}	A_{rms}	16.6
Continuous locked-rotor torque	T_o	Nm	2.629
Continuous locked-rotor current	I_o	A_{rms}	4.95
Rated voltage	Un	V_{AC}	220
Maximum winding voltage	U_{max}	V_{DC}	340
Maximum voltage to ground		V_{AC}	240
Voltage constant	K_{eU-v}	V_{rms}/k_{rpm}	36.1
Torque constant	K_t	N.m/ A_{rms}	0.53
Winding resistance	$R_{20 U-v}$	Ω	1.33
Winding inductance	L_{U-v}	mH	8.1
Rotor inertia (without brake)	J_M	$\times 10^{-4}$ kg.m ²	0.791
Rotor inertia (with brake)	J_M	$\times 10^{-4}$ kg.m ²	0.861
Mass (without brake)	m	Kg	2.3
Mass (with brake)	m	Kg	2.9
Thermal time constant		min ⁻¹	15
Maximum radial shaft load		N	392
Maximum axial shaft load		N	147

PRHD2 80

220VAC Torque and Speed Charts

PH2-L08A230

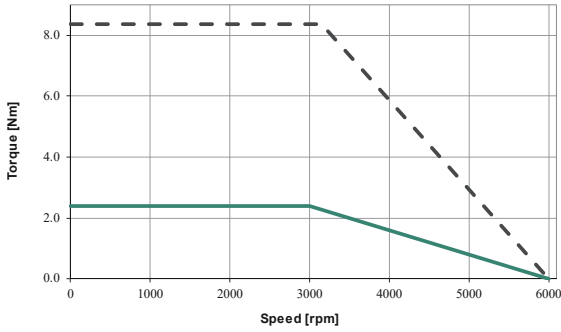

——— Continuous torque
- - - - - Peak operation

PRHD2 80 220VAC Overall Dimensions

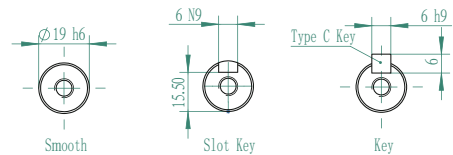
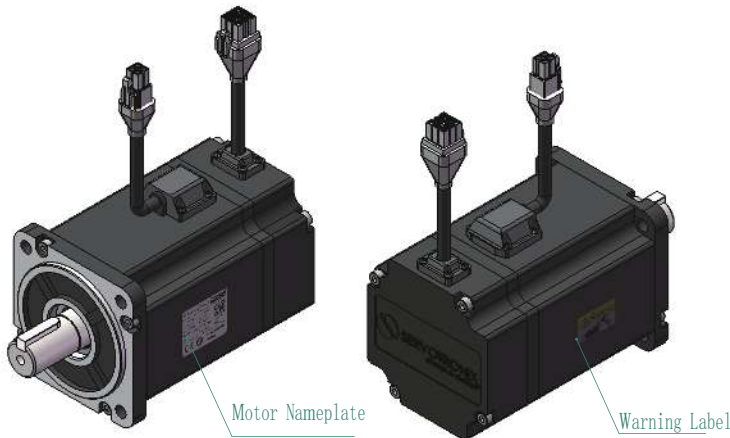
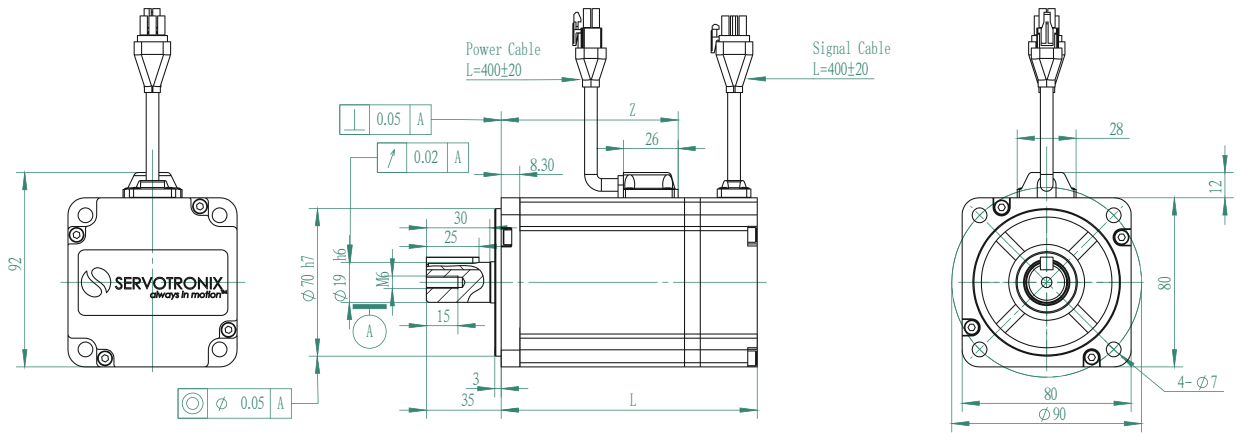

TYPE	L (mm)	L(mm)+Brake	Z (mm)	Z (mm)+Brake
PH2-L08A230xxTxxD	112	145.5	77	77
PH2-L08A230xxS3xD	114	147.5	77	77
PH2-L08A230xxM3xD	114	147.5	77	77

PRHD2 80

220VAC Specifications

TIME RATING
INSULATION CLASS
ENCLOSURE
PROTECTION CLASS

Continuous
F
Totally enclosed. Self-cooled
IP65

AMBIENT TEMPERATURE
RELATIVE HUMIDITY
NUMBER OF POLES
CERTIFICATION

-10 ... + 40 °C
20 ... 80%
10
CE/UL

			PH2-M08A230
Rated torque	M_n	Nm	2.39
Peak torque	T_{max}	Nm	8.36
Rated Speed	nN	min ⁻¹	3000
Maximum speed	n_{max}	min ⁻¹	6000
Rated power	P_N	kW	0.75
Rated current	I_N	A_{rms}	5
Maximum current	I_{max}	A_{rms}	18.1
Continuous locked-rotor torque	T_o	Nm	2.629
Continuous locked-rotor current	I_o	A_{rms}	5.5
Rated voltage	Un	V_{AC}	220
Maximum winding voltage	U_{max}	V_{DC}	340
Maximum voltage to ground		V_{AC}	240
Voltage constant	K_{eU-v}	V_{rms}/k_{rpm}	31.25
Torque constant	K_t	N.m/ A_{rms}	0.48
Winding resistance	$R_{20 U-v}$	Ω	0.75
Winding inductance	L_{U-v}	mH	2.6
Rotor inertia (without brake)	J_M	$\times 10^{-4}$ kg.m ²	1.72
Rotor inertia (with brake)	J_M	$\times 10^{-4}$ kg.m ²	1.74
Mass (without brake)	m	Kg	2.7
Mass (with brake)	m	Kg	3.3
Thermal time constant		min ⁻¹	15
Maximum radial shaft load		N	392
Maximum axial shaft load		N	147

PRHD2 80

220VAC Torque and Speed Charts

PH2-M08A230

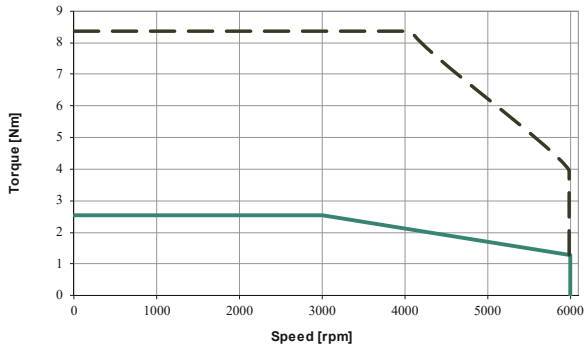

——— Continuous torque
- - - - - Peak operation

PRHD2 80 220VAC Overall Dimensions

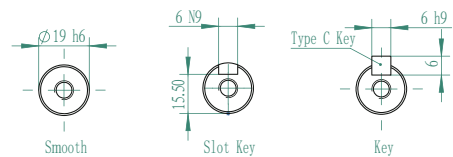
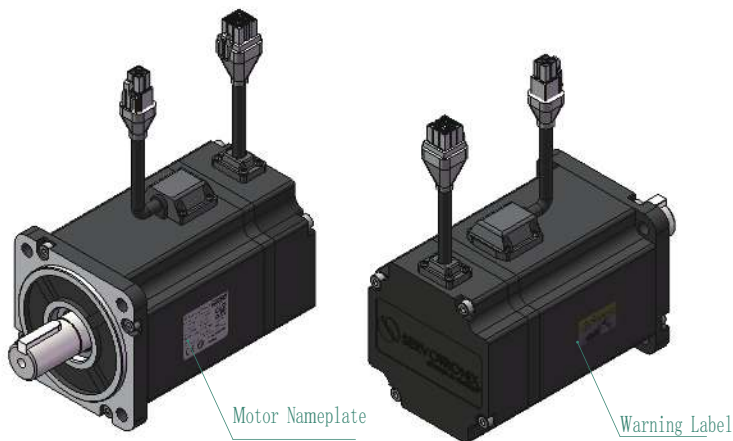
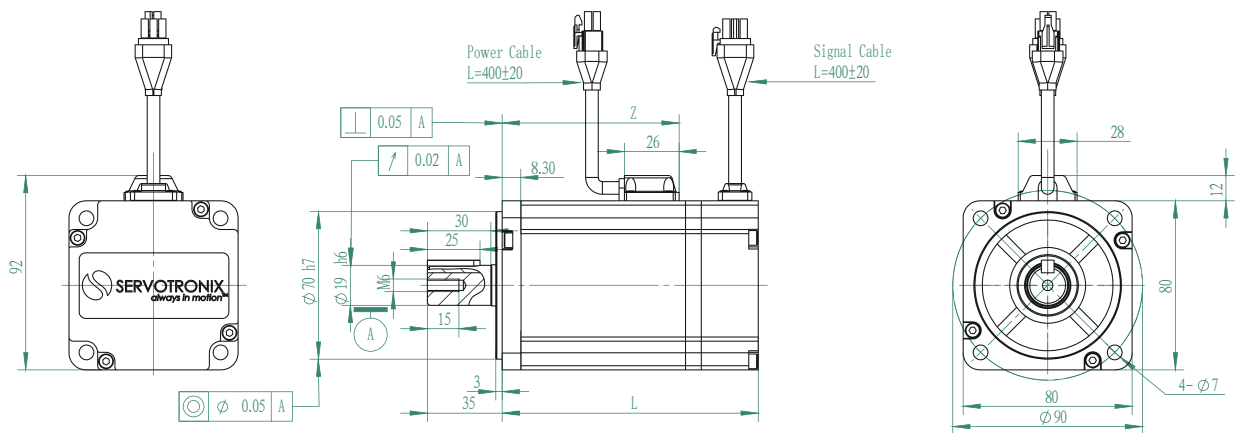

TYPE	L (mm)	L(mm)+Brake	Z (mm)	Z (mm)+Brake
PH2-M08A230xxTxxD	122	155	84	84
PH2-M08A230xxS3xD	124	157	84	84
PH2-M08A230xxM3xD	124	157	84	84

PRHD2 100

220VAC Specifications

TIME RATING	Continuous	AMBIENT TEMPERATURE	-10 ... + 40 °C
INSULATION CLASS	F	RELATIVE HUMIDITY	20 ... 80%
ENCLOSURE	Totally enclosed, Self cooled	POLES	10
PROTECTION CLASS	IP65	CERTIFICATION	CE/UL

			PH2-L10A230	PH2-L10B230	PH2-L10C230
Rated torque	M_n	Nm	3.18	4.78	6.37
Peak torque	T_{max}	Nm	9.54	14.34	19.11
Rated Speed	nN	min ⁻¹	3000	3000	3000
Maximum speed	n_{max}	min ⁻¹	5000	5000	5000
Rated power	P_N	kW	1	1.5	2
Rated current	I_N	A_{rms}	6	10	12
Maximum current	I_{max}	A_{rms}	20.5	34.2	37.3
Rated voltage	U_n	V_{AC}	220	220	220
Maximum winding voltage	U_{max}	V_{DC}	340	340	340
Maximum voltage to ground		V_{AC}	240	240	240
Voltage constant	K_{eu-v}	V_{rms}/k_{rpm}	34.4	33.7	36.8
Torque constant	K_t	N.m/ A_{rms}	0.53	0.48	0.53
Winding resistance	$R_{20 u-v}$	Ω	0.55	0.32	0.27
Winding inductance	L_{u-v}	mH	4.9	3.2	2.6
Rotor inertia (without brake)	J_M	$\times 10^{-4} \text{ kg.m}^2$	2.23	3.14	4.17
Rotor inertia (with brake)	J_M	$\times 10^{-4} \text{ kg.m}^2$	2.57	3.48	4.51
Mass (without brake)	m	Kg	3.7	4.6	5.5
Mass (with brake)	m	Kg	4.7	5.5	6.5
Thermal time constant		min ⁻¹	30	36	44.3
Maximum radial shaft load		N	490	490	490
Maximum axial shaft load		N	196	196	196

PRHD2 100

220VAC Torque and Speed Charts

PH2-L10A230

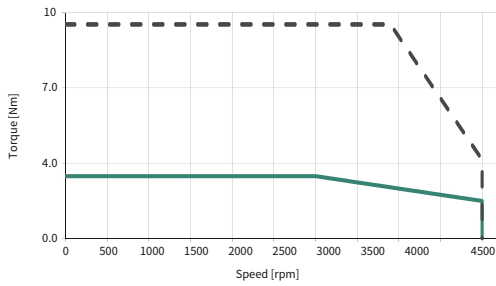

PH2-L10B230

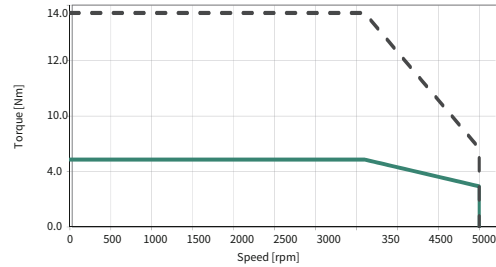

PH2-L10C230

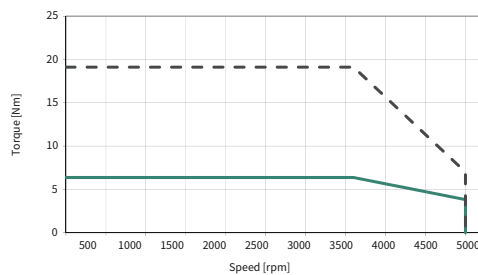

— Continuous torque
- - - Peak operation

PRHD2 100 220VAC Overall Dimensions

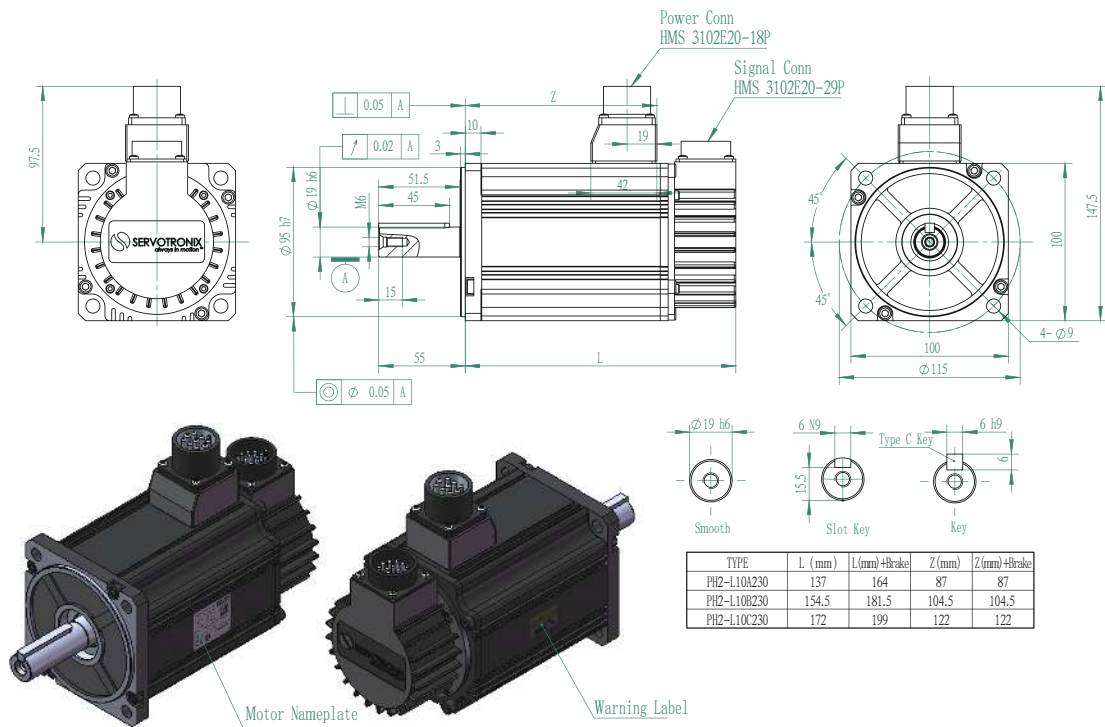

PRHD2 100

400VAC Specifications

TIME RATING	Continuous	AMBIENT TEMPERATURE	-10 ... + 40 °C
INSULATION CLASS	F	RELATIVE HUMIDITY	20 ... 80%
ENCLOSURE	Totally enclosed, Self cooled	POLES	10
PROTECTION CLASS	IP65	CERTIFICATION	CE/UL

			<i>PH2-L10A430</i>	<i>PH2-L10B430</i>	<i>PH2-L10C430</i>
Rated torque	M_n	Nm	3.18	4.78	6.37
Peak torque	T_{max}	Nm	9.54	14.34	19.11
Rated Speed	nN	min ⁻¹	3000	3000	3000
Maximum speed	n_{max}	min ⁻¹	5000	5000	5000
Rated power	P_N	kW	1	1.5	2
Rated current	I_N	A_{rms}	3	5	6
Maximum current	I_{max}	A_{rms}	9	18	18
Continuous locked-rotor torque	I_o	Nm	3.18	4.78	6.37
Continuous locked-rotor current	T_o	A_{rms}	3	5	6
Rated voltage	Un	V_{AC}	400	400	400
Maximum winding voltage	U_{max}	V_{DC}	620	620	620
Maximum voltage to ground		V_{AC}	480	480	480
Voltage constant	K_{eu-v}	V_{rms}/k_{rpm}	75.9	70.7	78.2
Torque constant	K_t	N.m/ A_{rms}	1.06	0.96	1.06
Winding resistance	$R_{20 u-v}$	Ω	2.8	1.26	1.1
Winding inductance	L_{u-v}	mH	22.6	12.7	11.1
Rotor inertia (without brake)	J_M	$\times 10^{-4}$ kg.m ²	2.23	3.14	4.17
Rotor inertia (with brake)	J_M	$\times 10^{-4}$ kg.m ²	2.57	3.48	4.51
Mass (without brake)	m	Kg	3.7	4.6	5.5
Mass (with brake)	m	Kg	4.7	5.5	6.5
Thermal time constant		min ⁻¹	30	36	44.3
Maximum radial shaft load		N	490	490	490
Maximum axial shaft load		N	196	196	196

PRHD2 100

400VAC Torque and Speed Charts

PH2-L10A430

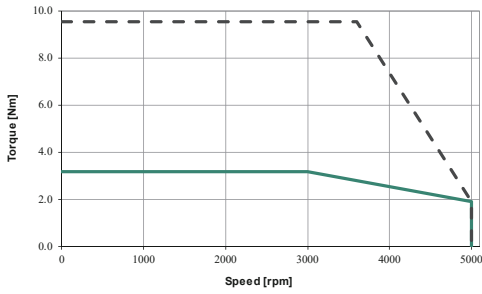

PH2-L10B430

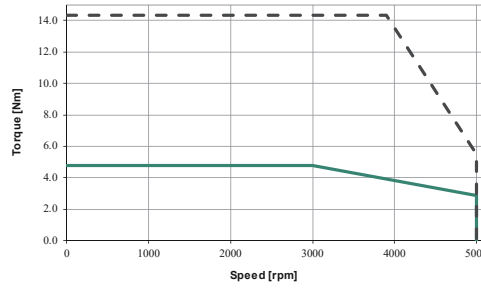

PH2-L10C430

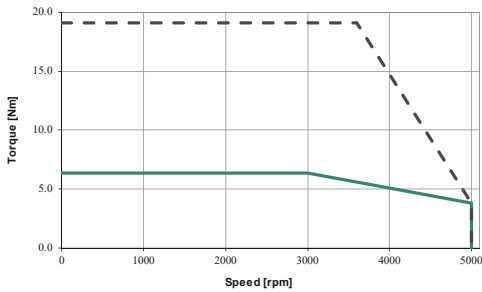

— Continuous torque
- - - Peak operation

PRHD2 100 400VAC Overall Dimensions

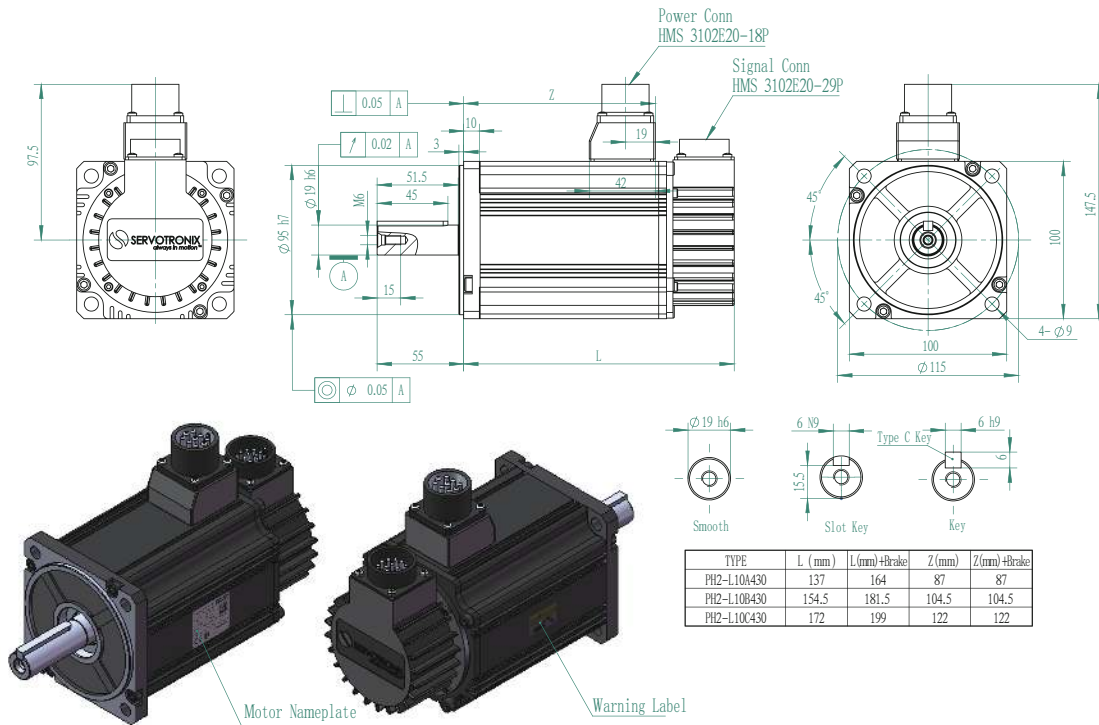

PRHD2 130

220VAC Specifications

TIME RATING	Continuous	AMBIENT TEMPERATURE	-10 ... + 40 °C
INSULATION CLASS	F	RELATIVE HUMIDITY	20 ... 80%
ENCLOSURE	Totally enclosed, Self cooled	POLES	10
PROTECTION CLASS	IP65	CERTIFICATION	CE/UL

			PH2-M13A215	PH2-M13B215	PH2-M138220
Rated torque	M_n	Nm	6.37	9.55	9.55
Peak torque	T_{max}	Nm	19.1	28.65	28.65
Rated Speed	nN	min ⁻¹	1500	1500	2000
Maximum speed	n_{max}	min ⁻¹	2000	2000	3000
Rated power	P_N	kW	1	1.5	2
Rated current	I_N	A_{rms}	5.6	8.7	12.7
Maximum current	I_{max}	A_{rms}	16.8	26.1	38.1
Rated voltage	U_n	V_{AC}	220	220	220
Maximum winding voltage	U_{max}	V_{DC}	340	340	340
Maximum voltage to ground		V_{AC}	240	240	240
Voltage constant	K_{eu-v}	V_{rms}/k_{rpm}	74.5	76.5	55.2
Torque constant	K_t	N.m/ A_{rms}	1.23	1.26	0.91
Winding resistance	$R_{20 u-v}$	Ω	0.9	0.59	0.28
Winding inductance	L_{u-v}	mH	9.9	7.1	3.6
Rotor inertia (without brake)	J_M	$\times 10^{-4} \text{ kg.m}^2$	8.45	12.32	12.97
Rotor inertia (with brake)	J_M	$\times 10^{-4} \text{ kg.m}^2$	8.6	12.5	13.16
Mass (without brake)	m	Kg	7.3	9.2	9.5
Mass (with brake)	m	Kg	10.1	11.5	11.9
Thermal time constant		min ⁻¹	33	33	32
Maximum radial shaft load		N	686	686	686
Maximum axial shaft load		N	343	343	343

PRHD2 130

220VAC Torque and Speed Charts

PH2-M13A215

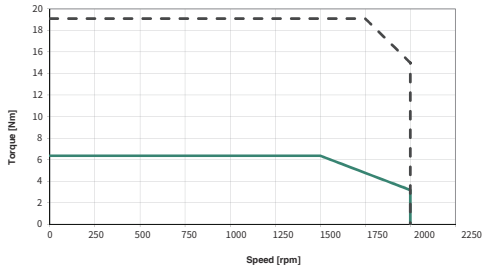

PH2-M13B215

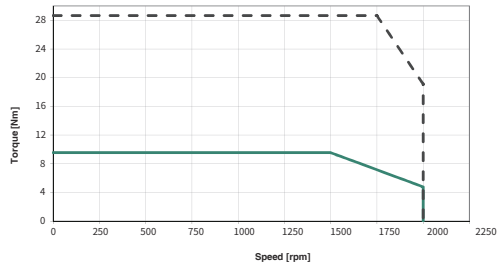

PH2-M13B220

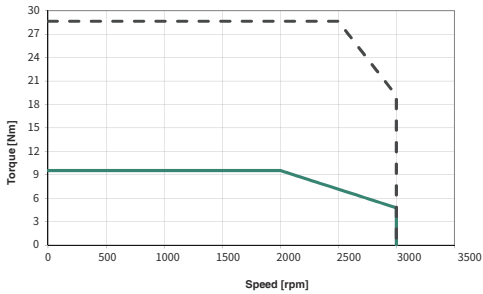

— Continuous torque
- - - Peak operation

PRHD2 130 220VAC Overall Dimensions

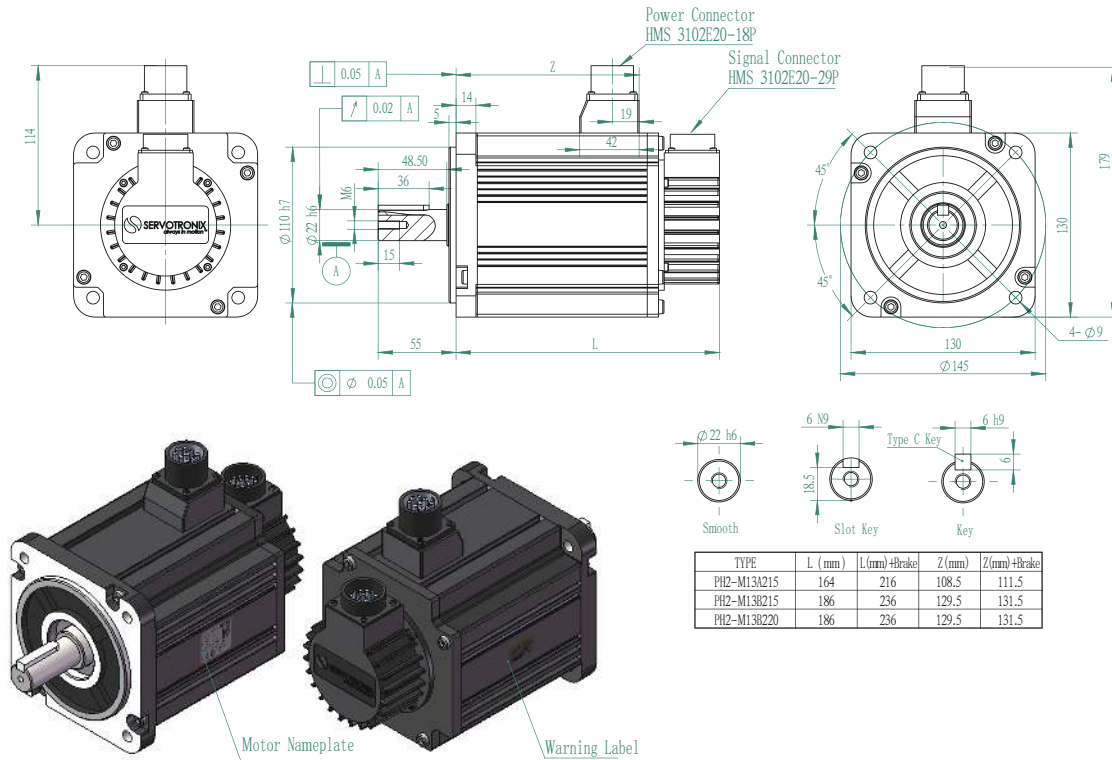

PRHD2 130

200VAC Specifications

TIME RATING	Continuous	AMBIENT TEMPERATURE	-10 ... + 40 °C
INSULATION CLASS	F	RELATIVE HUMIDITY	20 ... 80%
ENCLOSURE	Totally enclosed, Self cooled	POLES	10
PROTECTION CLASS	IP65	CERTIFICATION	CE/UL

			<i>PH2-M13C220</i>	<i>PH2-M13D220</i>	<i>PH2-M13E220</i>
Rated torque	M_n	Nm	5.39	8.34	11.5
Peak torque	T_{max}	Nm	16.17	25.02	34.5
Rated Speed	nN	min ⁻¹	2000	2000	2000
Maximum speed	n_{max}	min ⁻¹	3000	3000	3000
Rated power	P_N	kW	1.1	1.75	2.4
Rated current	I_N	A_{rms}	7.5	11.5	15.6
Maximum current	I_{max}	A_{rms}	21	33	45
Rated voltage	Un	V_{AC}	220	220	220
Maximum winding voltage	U_{max}	V_{DC}	340	340	340
Maximum voltage to ground		V_{AC}	240	240	240
Voltage constant	K_{eu-v}	V_{rms}/k_{rpm}	53.8	53.5	52
Torque constant	K_t	N.m/ A_{rms}	0.882	0.88	0.86
Winding resistance	$R_{20 u-v}$	Ω	0.75	0.47	0.31
Winding inductance	L_{u-v}	mH	5.65	3.7	2.5
Rotor inertia (without brake)	J_M	$\times 10^{-4} \text{ kg.m}^2$	12.5	18.5	24.2
Rotor inertia (with brake)	J_M	$\times 10^{-4} \text{ kg.m}^2$	14.5	20.5	26.2
Mass (without brake)	m	Kg	6.15	7.82	9.5
Mass (with brake)	m	Kg	8.81	10.44	12.1
Thermal time constant		min ⁻¹	23	29	36
Maximum radial shaft load		N	686	686	686
Maximum axial shaft load		N	343	343	343

PRHD2 130

220VAC Torque and Speed Charts

PH2-M13C220

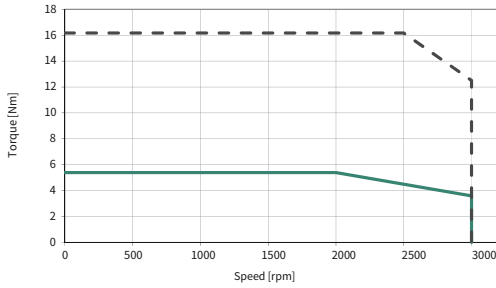

PH2-M13D220

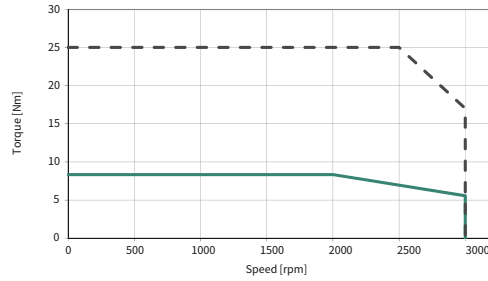

PH2-M13E220

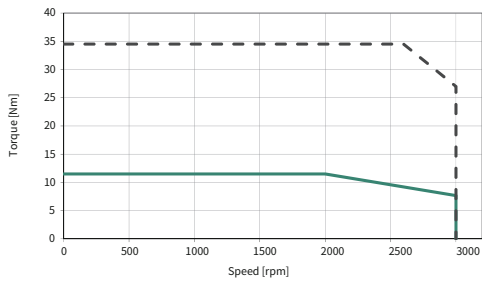

— Continuous torque
- - - Peak operation

PRHD2 130 220VAC Overall Dimensions

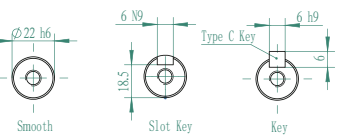
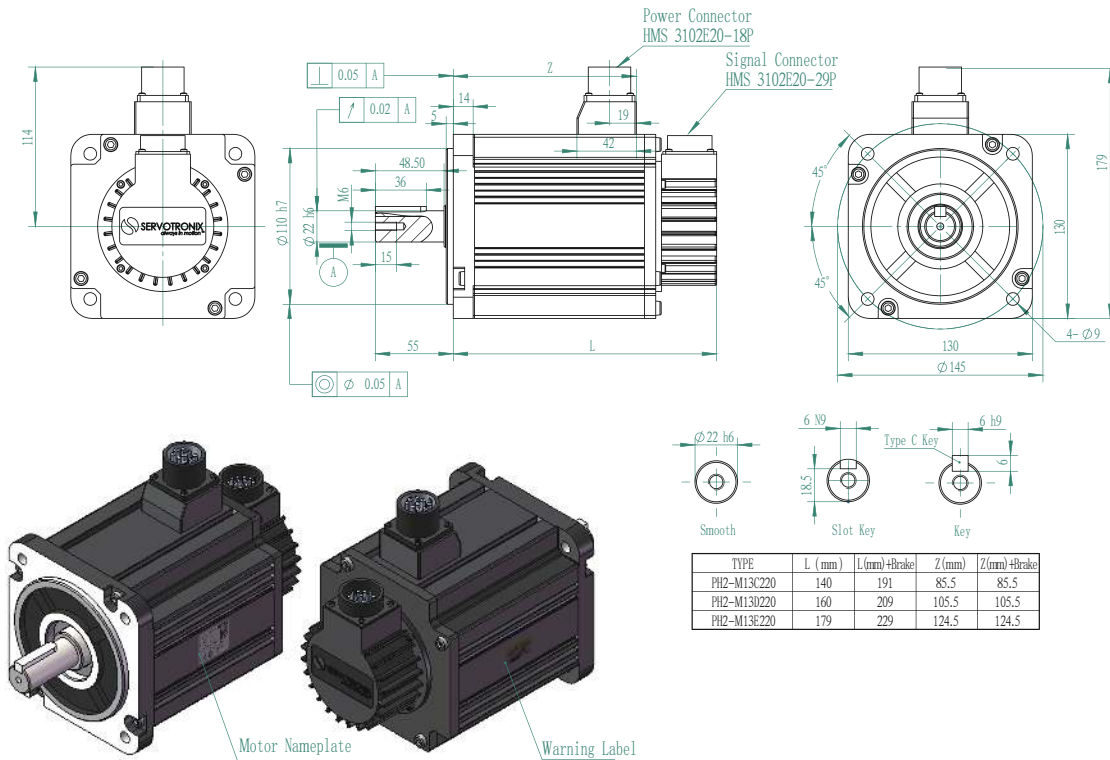

TYPE	L (mm)	L (mm)+Brake	Z (mm)	Z (mm)+Brake
PH2-M13C220	140	191	85.5	85.5
PH2-M130220	160	209	105.5	105.5
PH2-M13E220	179	229	124.5	124.5

PRHD2 130

400VAC Specifications

TIME RATING	Continuous	AMBIENT TEMPERATURE	-10 ... + 40 °C
INSULATION CLASS	F	RELATIVE HUMIDITY	20 ... 80%
ENCLOSURE	Totally enclosed, Self cooled	POLES	10
PROTECTION CLASS	IP65	CERTIFICATION	CE/UL

			PH2-M13C420	PH2-M13D420	PH2-M134220
Rated torque	M_n	Nm	5.39	8.34	11.5
Peak torque	T_{max}	Nm	16.17	25.02	34.5
Rated Speed	nN	min ⁻¹	2000	2000	2000
Maximum speed	n_{max}	min ⁻¹	3000	3000	3000
Rated power	P_N	kW	1.1	1.75	2.4
Rated current	I_N	A_{rms}	3.8	5.4	8.1
Maximum current	I_{max}	A_{rms}	11.4	16	24
Continuous locked-rotor torque	T_o	Nm	6	9.5	12.5
Continuous locked-rotor current	T_o	A_{rms}	4.23	6.15	8.8
Rated voltage	Un	V_{AC}	400	400	400
Maximum winding voltage	U_{max}	V_{DC}	620	620	620
Maximum voltage to ground		V_{AC}	480	480	480
Voltage constant	K_{eu-v}	V_{rms}/k_{rpm}	95	102.5	98
Torque constant	K_t	N.m/ A_{rms}	1.57	1.7	1.62
Winding resistance	$R_{20 u-v}$	Ω	2.11	1.43	0.925
Winding inductance	L_{u-v}	mH	16.8	12.6	8
Rotor inertia (without brake)	J_M	$\times 10^{-4}$ kg.m ²	12.5	18.5	24.2
Rotor inertia (with brake)	J_M	$\times 10^{-4}$ kg.m ²	14.5	20.5	26.2
Mass (without brake)	m	Kg	6.15	7.82	9.5
Mass (with brake)	m	Kg	8.81	10.44	12.1
Thermal time constant		min ⁻¹	23	29	36
Maximum radial shaft load		N	686	686	686
Maximum axial shaft load		N	343	343	343

PRHD2 130

400VAC Torque and Speed Charts

PH2-M13C420

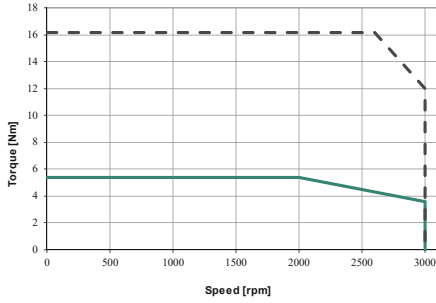

PH2-M13D420

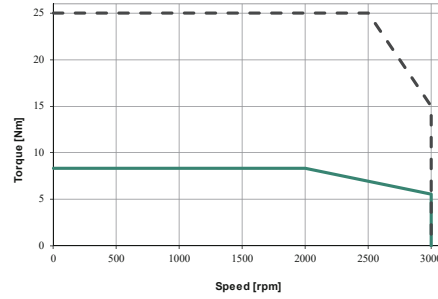

PH2-M13E420

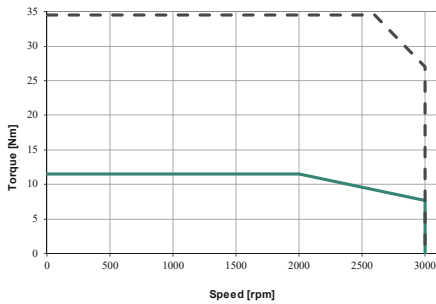

— Continuous torque
- - - Peak operation

PRHD2 130 400VAC Overall Dimensions

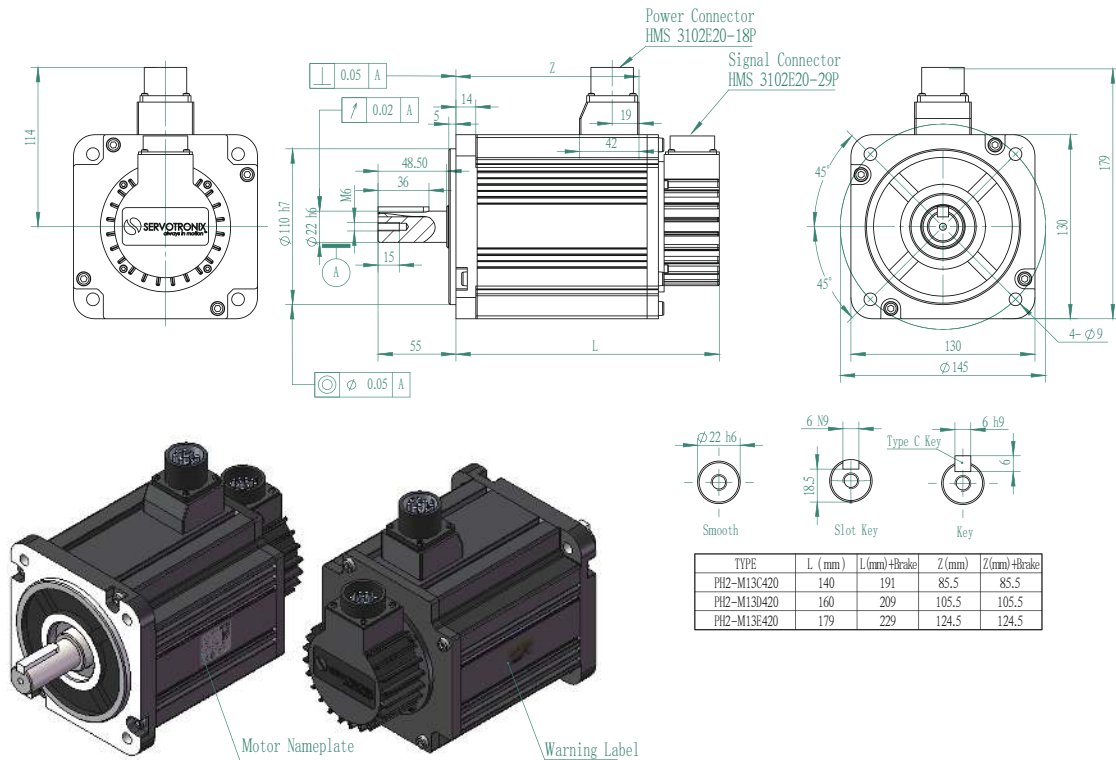

PRHD2 180

220VAC Specifications

TIME RATING	Continuous	AMBIENT TEMPERATURE	-10 ... + 40 °C
INSULATION CLASS	F	RELATIVE HUMIDITY	20 ... 80%
ENCLOSURE	Totally enclosed, Self cooled	POLES	10
PROTECTION CLASS	IP65	CERTIFICATION	CE/UL

			PH2-M18A215	PH2-M18B215	PH2-M18C215	PH2-M18D215
Rated torque	M_n	Nm	19.1	28.6	35	48
Peak torque	T_{max}	Nm	47.75	71.5	87.5	120
Rated Speed	nN	min ⁻¹	1500	1500	1500	1500
Maximum speed	n_{max}	min ⁻¹	3000	3000	3000	3000
Rated power	P_N	kW	3	4.5	5.5	7.5
Rated current	I_N	A_{rms}	23	33.5	42	55.1
Maximum current	I_{max}	A_{rms}	58.67	85.46	107.14	140.56
Rated voltage	U_n	V_{AC}	220	220	220	220
Maximum winding voltage	U_{max}	V_{DC}	340	340	340	340
Maximum voltage to ground		V_{AC}	240	240	240	240
Voltage constant	K_{eU-V}	V_{rms}/k_{rpm}	56.21	57.97	56.51	57.09
Torque constant	K_t	N.m/ A_{rms}	0.928	0.958	0.934	0.944
Winding resistance	$R_{20 u-v}$	Ω	0.118	0.074	0.049	0.038
Winding inductance	L_{u-v}	mH	2.4	1.5	1.1	0.9
Rotor inertia (without brake)	J_M	$\times 10^{-4} \text{ kg.m}^2$	42.4	62.3	84.1	122
Rotor inertia (with brake)	J_M	$\times 10^{-4} \text{ kg.m}^2$	49.4	69.3	91.1	129
Mass (without brake)	m	Kg	18	24	30	36
Mass (with brake)	m	Kg	23	29	35	41
Thermal time constant		min ⁻¹	37	48	55	65
Maximum radial shaft load		N	1470	1470	1764	1764
Maximum axial shaft load		N	490	490	588	588

PRHD2 180

220VAC Torque and Speed Charts

PH2-M18A215

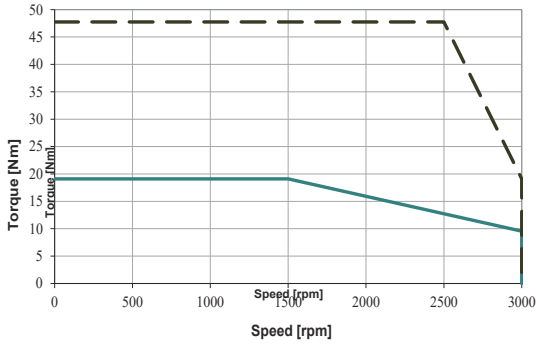

PH2-M18B215

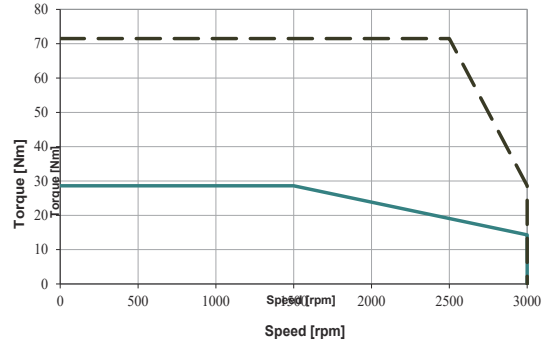

— Continuous torque
- - - Peak operation

PRHD2 180AB 220VAC DIMENSIONS

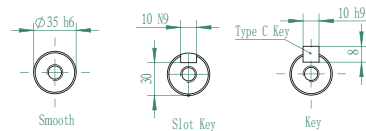
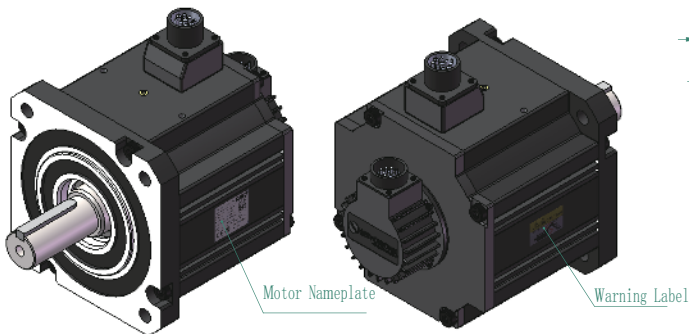
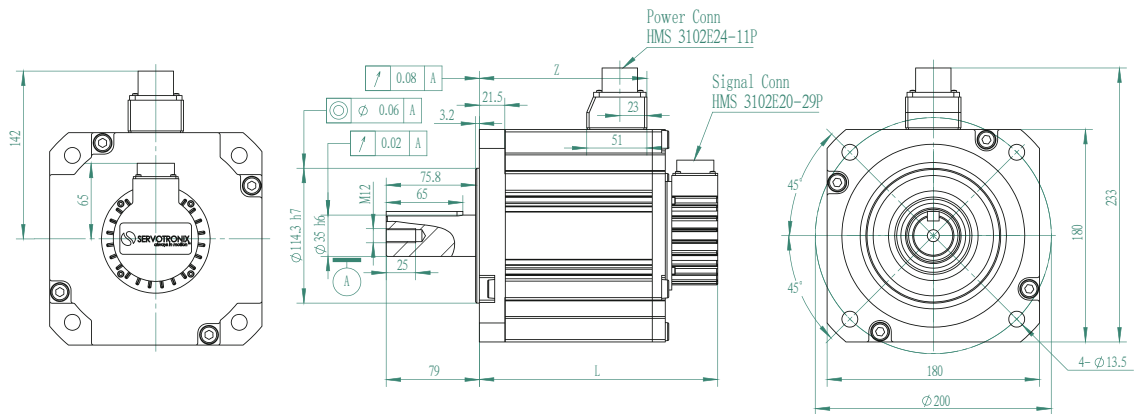

TYPE	L (mm)	L(mm)+Brake	Z (mm)	Z (mm)+Brake
PH2-M18A215	202	251	142	142
PH2-M18B215	235	284	175	175

PRHD2 180

220VAC Torque and Speed Charts

PH2-M18C215

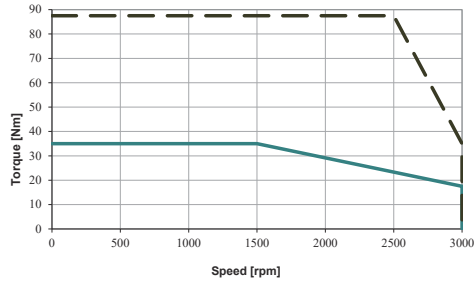

PH2-M18D215

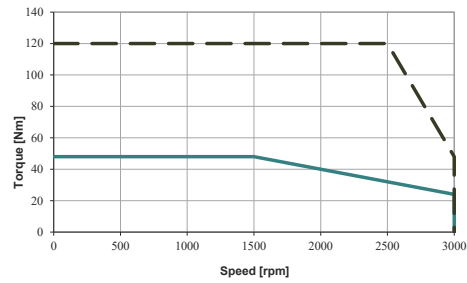

— Continuous torque
- - - Peak operation

PRHD2 180CD 220VAC DIMENSIONS

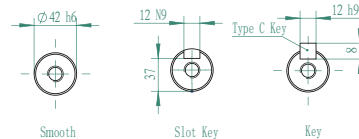
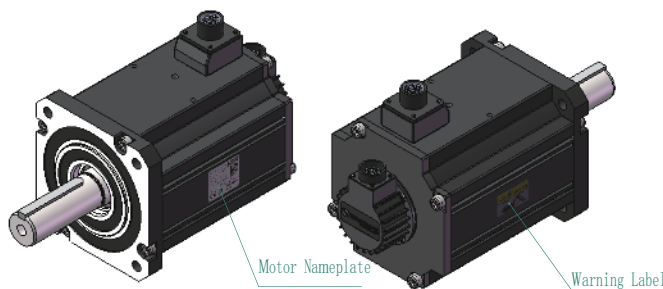
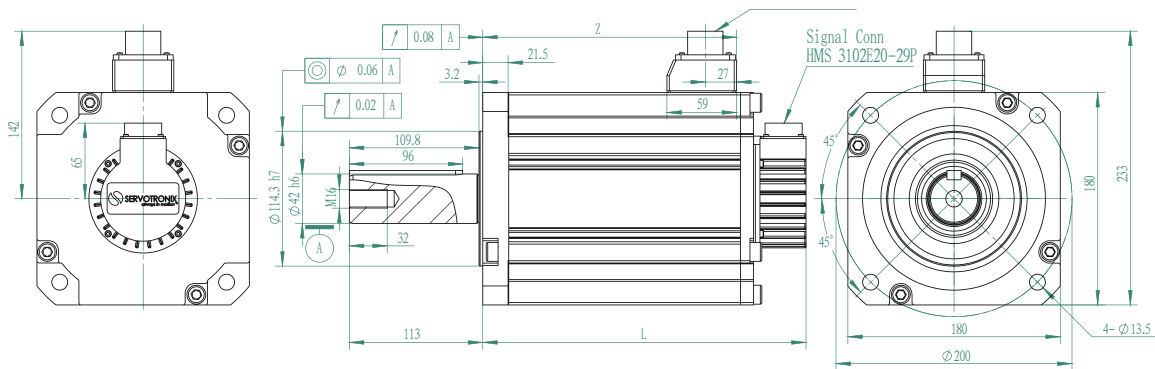

TYPE	L (mm)	L(mm)+Brake	Z (mm)	Z(mm)+Brake
PH2-M18A215	274	317	215	209
PH2-M18B215	329	355	250	247

PRHD2 180

400VAC Specifications

TIME RATING	Continuous	AMBIENT TEMPERATURE	-10 ... + 40 °C
INSULATION CLASS	F	RELATIVE HUMIDITY	20 ... 80%
ENCLOSURE	Totally enclosed, Self cooled	POLES	10
PROTECTION CLASS	IP65	CERTIFICATION	CE/UL

			PH2-M18A415	PH2-M18B415	PH2-M18C415	PH2-M18D415
Rated torque	M_n	Nm	19.1	28.6	35	48
Peak torque	T_{max}	Nm	47.75	71.5	87.5	120
Rated Speed	n_N	min^{-1}	1500	1500	1500	1500
Maximum speed	n_{max}	min^{-1}	3000	3000	3000	3000
Rated power	P_N	kW	3	4.5	5.5	7.5
Rated current	I_N	A_{rms}	11.8	18.5	22.4	29
Maximum current	I_{max}	A_{rms}	30	47	57.2	74
Continuous locked-rotor torque	I_o	Nm	21	32	38	52
Continuous locked-rotor current	T_o	A_{rms}	12.9	20.7	24.3	31.4
Rated voltage	U_n	V_{AC}	400	400	400	400
Maximum winding voltage	U_{max}	V_{DC}	620	620	620	620
Maximum voltage to ground		V_{AC}	480	480	480	480
Voltage constant	K_{eu-v}	V_{rms}/k_{rpm}	115	105.5	110	126
Torque constant	K_t	$N.m/A_{rms}$	1.9	1.75	1.81	2.08
Winding resistance	$R_{20\ u-v}$	Ω	0.45	0.242	0.185	0.172
Winding inductance	L_{u-v}	mH	8.22	5	3.8	4
Rotor inertia (without brake)	J_M	$\times 10^{-4} \text{ kg.m}^2$	42.4	62.3	84.1	122
Rotor inertia (with brake)	J_M	$\times 10^{-4} \text{ kg.m}^2$	49.4	69.3	91.1	129
Mass (without brake)	m	Kg	18	24	30	36
Mass (with brake)	m	Kg	23	29	35	41
Thermal time constant		min^{-1}	37	48	55	65
Maximum radial shaft load		N	1470	1470	1764	1764
Maximum axial shaft load		N	490	490	588	588

PRHD2 180

400VAC Torque and Speed Charts

PH2-M18A415

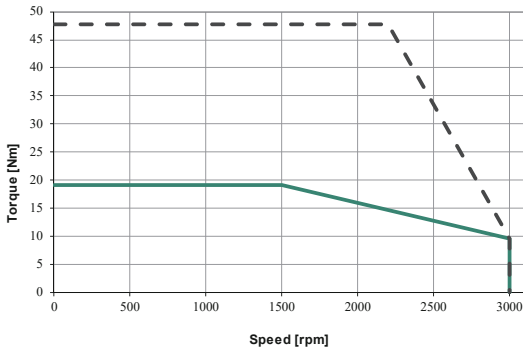

PH2-M18B415

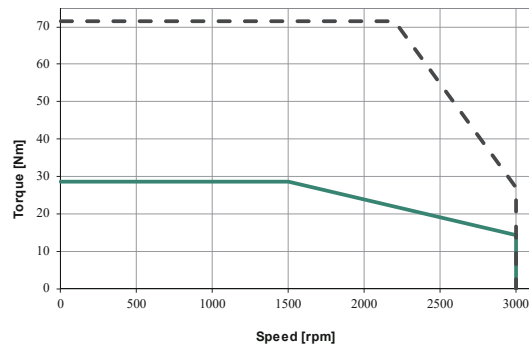

——— Continuous torque
- - - - - Peak operation

PRHD2 180AB 400VAC DIMENSIONS

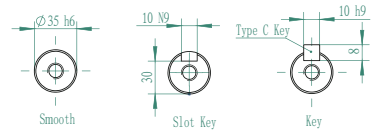
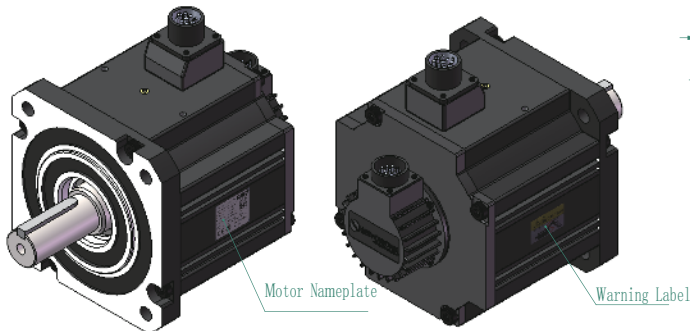
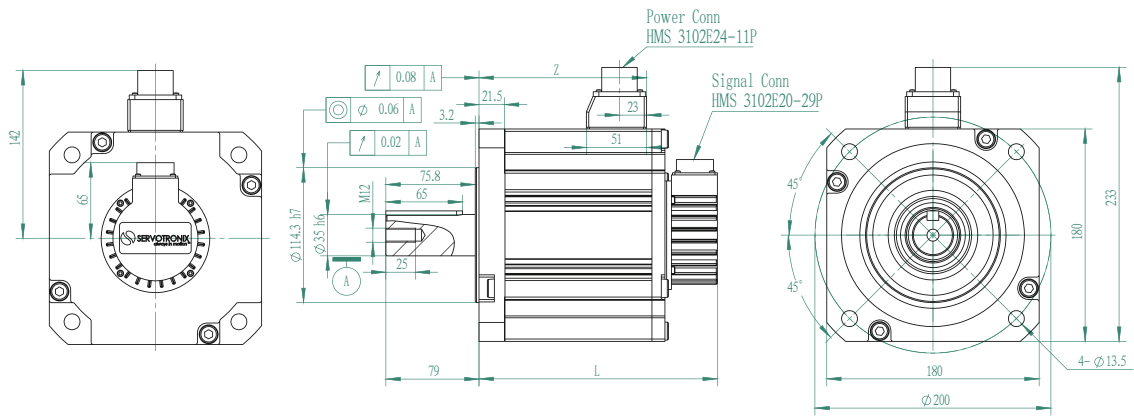

TYPE	L (mm)	L(mm)+Brake	Z (mm)	Z(mm)+Brake
PH2-M18A415	202	251	142	142
PH2-M18B415	235	284	175	175

PRHD2 180

400VAC Torque and Speed Charts

PH2-M18C415

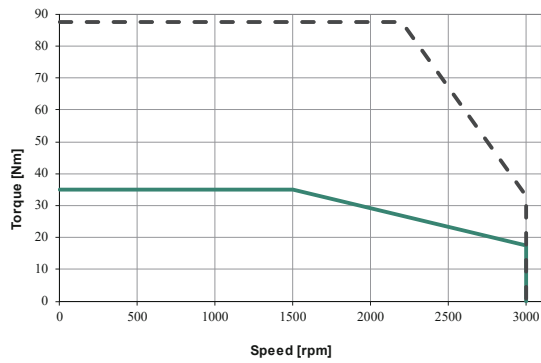

PH2-M18D415

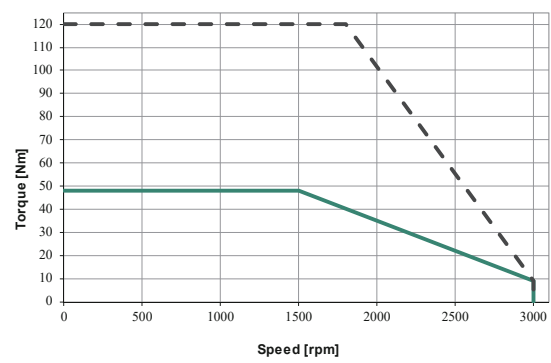

— Continuous torque
- - - Peak operation

PRHD2 180CD 400VAC DIMENSIONS

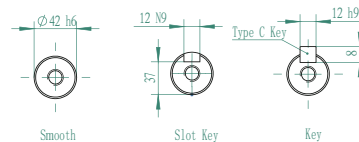
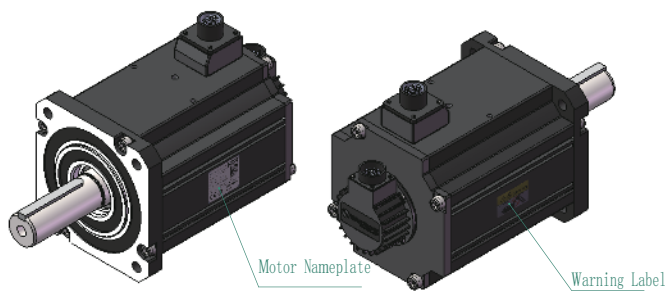
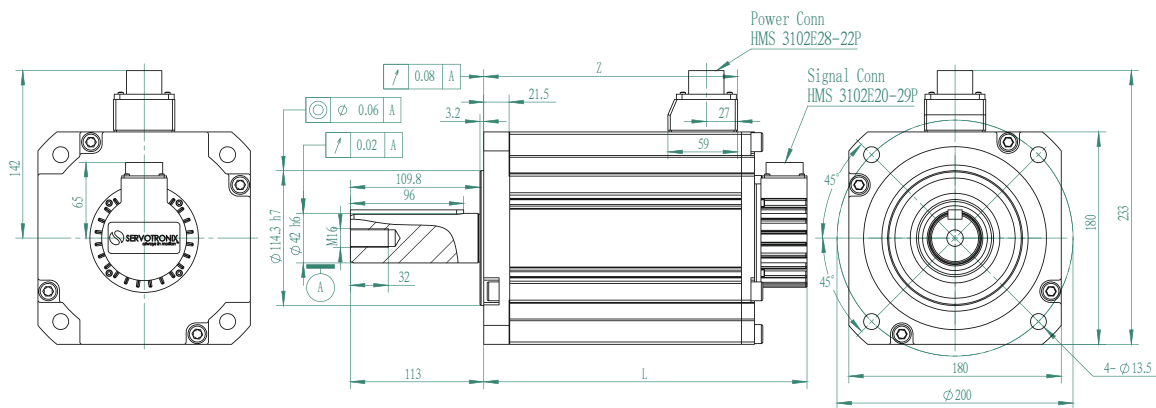

TYPE	L (mm)	L(mm)+Brake	Z (mm)	Z(mm)+Brake
PH2-M18C415	274	317	215	209
PH2-M18D415	329	355	250	247

Motor Wiring Connections

*Feedback type:
S3 and M3 (sensAR)*

*Feedback type:
T1, T4 (Tamagawa)*

D type, AMP

P/N: AMP-172169-1
P/N: Pin 770835-1

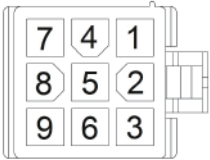

Motors: PH2-M04, PH2-M06
PH2-M08, PH2-L04
PH2-L06, PH2-L08
PH2- R04, PH2- R06
PH2-R08

Motor Connector	Signal Name	Drive	Twisted Pair
1	DATA +	1	T/P
2	DATA -	14	
3	N.C.		
4	N.C.		
5	N.C.		
6	5V	11	T/P
7	GND	24	
8	Shield	26	
9	N.C.		

Motor Connector	Signal Name	Drive	Twisted Pair
1	DATA +	1	T/P
2	DATA -	14	
3	N.C.		
4	VB		
5	GND		
6	5V	11	T/P
7	GND	24	
8	Shield	26	
9	N.C.		

*Feedback type:
S3 and M3 (sensAR)*

*Feedback type:
T1, T4 (Tamagawa)*

A type MIL

P/N: HMS3102E20-29P

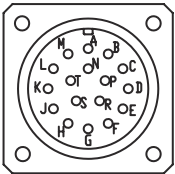

Motors: PH2-L10, PH2-L13
PH2-M13, PH2-M18

Motor Connector	Signal Name	Drive	Twisted Pair
A, B, C, D	N.C.		
E	DATA +	1	T/P
F	DATA -	14	
G	GND	24	T/P
H	5V	11	
J	Shield	26	
K, L, M, N, P, R, S, T,	N.C.		

Motor Connector	Signal Name	Drive	Twisted Pair
A, B, C, D	N.C.		
E	DATA +	1	T/P
F	DATA -	14	
G	GND	24	T/P
H	5V	11	
J	Shield	26	
K, L, M, N, P, R	N.C.		
S	GND		
T	VB		

Motor Wiring Connections

Motor power connector without brake

D type AMP 4 poles

P/N: AMP-172167-1
P/N: Pin 770903-1

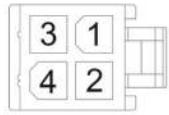

Motors: PH2-M04,PH2-M06,
PH2-M08,PH2-L04
PH2-L06,PH2-L08,
PH2-R04,PH2-R06,
PH2- R08

Motor Con- nector	Signal Name
1	U
2	V
3	W
4	PE

Motor power connector with brake

D type AMP 6 poles

P/N: AMP-172168-1
P/N: Pin 770903-1

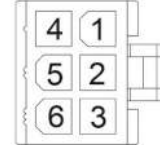

Motors: PH2-M04,PH2-M06,
PH2-M08,PH2-L04
PH2-L06,PH2-L08,
PH2-R04, PH2-R06,
PH2-R08

Motor Con- nector	Signal Name
1	U
2	V
4	W
5	PE
3	Brake_24V
6	Brake_0V

Motor power connector without brake

A type MIL

P/N: HMS3102E20-18P

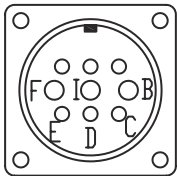

Motors: PH2-M13, PH2-L10,

Motor Connector	Signal Name
E	PE
F	U
I	V
B	W
C	N/A
D	N/A

Motor power connector with brake

Motor Connector	Signal Name
E	PE
F	U
I	V
B	W
C	Brake_24V
D	Brake_0V

Motor power connector without brake

A type MIL

P/N: HMS3102E24-11P

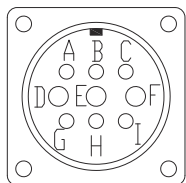

Motors: PH2-L13,PH2- M18A,
PH2-M18B

Motor Connector	Signal Name
F	U
E	V
D	W
G	PE
H	N/A
I	N/A

Motor power connector with brake

Motor Connector	Signal Name
F	U
E	V
D	W
G	PE
H	Brake_24V
I	Brake_0V

Motor power connector without brake

A type MIL

P/N: HMS3102E28-22P

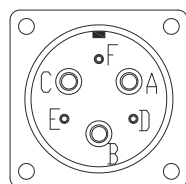

Motors: PH2-M18C, PH2-M18D,

Motor Connector	Signal Name
A	U
B	V
C	W
D	PE
E	N/A
F	N/A

Motor power connector with brake

Motor Connector	Signal Name
F	U
E	V
D	W
G	PE
H	Brake_24V
I	Brake_0V

Cables

Feedback Cable | PVC Cable

Cable P/N	Encoder	Connector	Adapted Motor	Drive	Drawing
CBL-FBPH2□S300D0XX	SensAR single-turn	AMP	PH2-L/M04 PH2-L/M06 PH2-L/M08	All CDHD2/CDHD/ DDHD	
CBL-FBPH2□S300D0XX	Tamagawa single-turn	AMP	PH2-L/M04 PH2-L/M06 PH2-L/M08	All CDHD2/CDHD/ DDHD	
CBL-FBPH2□M300D0XX	SensAR multi-turn	AMP	PH2-L/M04 PH2-L/M06 PH2-L/M08	All CDHD2/CDHD/ DDHD	
CBL-FBPH2□T300D0XX	Tamagawa multi-turn	AMP	PH2-L/M04 PH2-L/M06 PH2-L/M08	All CDHD2/CDHD/ DDHD	
CBL-FBPH2□S300A0XX	SensAR single-turn	MIL	PH2-L10 PH2-L/M13 PH2-M18	All CDHD2/CDHD/ DDHD	
CBL-FBPH2□S300A0XX	Tamagawa single-turn	MIL	PH2-L10 PH2-L/M13 PH2-M18	All CDHD2/CDHD/ DDHD	
CBL-FBPH2□M300A0XX	SensAR multi-turn	MIL	PH2-L10 PH2-L/M13 PH2-M18	All CDHD2/CDHD/ DDHD	
CBL-FBPH2□T300A0XX	Tamagawa multi-turn	MIL	PH2-L10 PH2-L/M13 PH2-M18	All CDHD2/CDHD/ DDHD	

1. □ indicates cable flexibility; 1 represents non-dragable chain, and 2 represents dragable chain

2. XX indicates the cable length; the available lengths include 3m, 5m, 10m, 15m and 20m.

Please contact the corresponding salesman for any special length requirement

Cables

Power Cable | PVC Cables Flying Leads

Cable P/N	Brake	Connector	Adapted Motor	Drive	Drawing
CBL-PWPH2□0000D0XX	Without brake	AMP	PH2-L/M04/06/08	All CDHD2/CDHD/ DDHD	
CBL-PWPH2□0001D0XX	With brake	AMP	PH2-L/M04/06/08	All CDHD2/CDHD/ DDHD	
CBL-PWPH2□0000A0XX	Without brake	MIL	PH2-L10 PH2-M13	All CDHD2/CDHD/ DDHD	
CBL-PWPH2□0001A0XX	With brake	MIL	PH2-L10 PH2-M13	All CDHD2/CDHD/ DDHD	
CBL-PWPH2□0000A1XX	Without brake	MIL	PH2-L13 PH2-M18A\B	All CDHD2/CDHD/ DDHD	
CBL-PWPH2□0001A1XX	With brake	MIL	PH2-L13 PH2-M18A\B	All CDHD2/CDHD/ DDHD	
CBL-PWPH2□0000A2XX	Without brake	MIL	PH2-M18C/D	All CDHD2/CDHD/ DDHD	
CBL-PWPH2□0001A2XX	With brake	MIL	PH2-M18C/D	All CDHD2/CDHD/ DDHD	

1. □ indicates cable flexibility; 1 represents non-dragable chain, and 2 represents dragable chain

2. XX indicates the cable length; the available lengths include 3m, 5m, 10m, 15m and 20m.

Please contact the corresponding salesman for any special length requirement

PRH02 Series

High-Performance Permanent Magnet Synchronous Servo Motor

About Servotronics

Servotronics Motion Control develops and manufactures standard and customized automation solutions with a focus on motion control. Over decades, the company has developed generations of high-performance servo drive families and motion-control solutions tailored to customer needs and designed to meet the form, fit, functionality, and cost specifications of a wide range of applications and industries. With a global customer base of leading machine builders and automation system suppliers, Servotronics's guiding principles are to provide its customers with high-quality products, cost-effective solutions, and on-time deliveries.

202005_V6



info@servotronics.com www.servotronics.com